



# 3HP Transportation PMAC Air Compressors Operating & Maintenance Manual

*Please read and save these instructions. Read carefully before attempting to assemble, install, operate or maintain the product described. Protect yourself and others by observing all safety information. Failure to comply with instructions could result in personal injury and/or property damage! Retain instructions for future reference.*



## Table of Contents

<b>1. General Information</b>	<b>5</b>
1.1 Safety Guidelines	5
1.2 Oil-less Scroll Technology	6
1.2.2 Scroll Compression Cycle	6
1.2.3 Oil-less benefits	6
1.3 Terminology	7
1.4 Application Guidelines	8
1.4.1 Ambient Temperature and Duty Cycle	8
1.4.2 Altitude Performance Characteristics	8
1.4.3 Inlet Air	8
1.4.4 Compressed Air Plumbing	8
1.4.5 Water Exposure	9
1.4.6 Maintenance Considerations	9
1.4.7 Uncrating	10
1.4.8 System and Major Component Identification	10
1.4.9 Powerex Transportation Model Numbering	12
1.5 General Performance	12
<b>2. Architecture Specific Information</b>	<b>13</b>
2.1 Scroll Direct Coupled (SDC)	13
2.1.1 Maintenance Schedule	13
2.1.2 SDC with PMAC Motor	14
2.1.2.1 Typical System and Major Component Identification Locations	14
2.1.2.2 Lifting / Handling	15
2.1.2.3 Motor Replacement Procedure	15
2.1.2.4 Troubleshooting Guide - SDC with Induction Motor	17
2.1.2.5 Inverter Status Lights	18
<b>3. Scroll Air End Maintenance Procedures</b>	<b>19</b>
3.1 Bearing Lubrication	19
3.1.1 OS Bearing Lubrication	20
3.1.2 Pin Crank Bearing Lubrication	22
3.2 Tip Seal Replacement	23
3.3 Insulation Tube Replacement	27
3.4 Fin Cleaning	28
3.5 Cooling Fan Cleaning	29

3.6 Filter Replacement ..... 30

    3.6.1 Filter Assembly VP000542AV..... 30

3.7 Drive Coupling Inspection ..... 31

3.8 General Inspection..... 33

**4. Powerex Limited Warranty – Applicable to OEM Customers Only ..... 34**

THIS PAGE IS INTENTIONALLY LEFT BLANK

## Description

### 1. General

The Powerex compressor in its simplest state is a motor connected to a scroll air end via a coupling. From there, Powerex has many variations from that basic setup to systems with an enclosure, built-in controls, and an air dryer. The system you have purchased or received on a vehicle may vary from the images found in this manual due to minor differences in configurations. The following is a list of optional components which may or may not be included:

- Direct mounted inlet air filter
- Air filter restriction indicator
- Isolator mounts
- Aftercooler
- Check valve
- Pressure relief valve

Along with the various add-ons listed above, Powerex also has a variety of baseplates due to varying customer needs. Though the baseplate may look different, the same maintenance requirements and procedures apply.

#### 1.1 Safety Guidelines

This manual contains information that is very important to know and understand. This information is provided for SAFETY and to PREVENT EQUIPMENT PROBLEMS. To help recognize this information, observe the following symbols:

**⚠ DANGER** Danger indicates an imminently hazardous situation which, if not avoided, WILL result in death or serious injury.

**⚠ WARNING** Warning indicates a potentially hazardous situation which, if not avoided, COULD result in death or serious injury.

**⚠ CAUTION** Caution indicates a potentially hazardous situation which, if not avoided, MAY result in minor or moderate injury.

**NOTICE** Notice indicates important information, that if not followed, may cause damage to equipment.

NOTE: Note indicates information that requires special attention.

#### Breathable Air Warning

**⚠ WARNING** This compressor/pump is NOT equipped and should NOT be used “as is” to supply breathing quality air. For any application of air for human consumption, you must fit the air compressor/pump with suitable in-line safety and alarm equipment. This additional equipment is necessary to properly filter and purify the air to meet minimal specifications for Grade D breathing as described in Compressed Gas Association Commodity Specification G 7.1 - 1966, OSHA 29 CFR 1910. 134, ANSI and/or Canadian Standards Associations (CSA).

#### DISCLAIMER OF WARRANTIES

IN THE EVENT THE COMPRESSOR IS USED FOR THE PURPOSE OF BREATHING AIR APPLICATION AND PROPER IN-LINE SAFETY AND ALARM EQUIPMENT IS NOT SIMULTANEOUSLY USED, EXISTING WARRANTIES ARE VOIDED, AND POWEREX DISCLAIMS ANY LIABILITY WHATSOEVER FOR ANY LOSS, PERSONAL INJURY OR DAMAGE.

**⚠ WARNING** Never operate compressor without protective guards. This unit can start automatically without warning. Personal injury or property damage may occur from contact with moving parts.

**⚠ WARNING** Always follow appropriate lockout tagout procedures to isolate the compressor from electrical and pneumatic energy prior to doing any work on the air compressor.

## 1.2 Oil-less Scroll Technology

Our innovative scroll technology is completely oilless, extremely quiet, and energy efficient. The scroll pump has few moving parts, making it reliable and easier to maintain. The self-lubricating tip seals and absence of a gearbox means the pump is completely oil-less.

### 1.2.2 Scroll Compression Cycle

The Powerex oil-less rotary scroll air compressor is based on the theory of scroll compression. A scroll is a free standing, intricate spiral bounded on one side by a solid, flat plane or base. A scroll set, the basic compression element of a scroll compressor, is made up of two identical spirals which form right and left-hand parts. One of these scroll components is indexed or phased 180° with respect to the other so the scrolls can mesh. Crescent-shaped gas pockets are formed and bounded by the spirals and the base plate of both scrolls. As the moving scroll is orbited around the fixed scroll, the pockets formed by the meshed scrolls follow the spiral toward the center and diminish in size as shown in Figure 1. The moving scroll is prevented from rotating during this process, so the 180° phase relationship of the scrolls is maintained. The compressor's inlet is at the outer boundary of the scrolls. The compressed gas is discharged through the outlet at the center of the fixed scroll, so no valves are needed.

### 1.2.3 Oil-less Benefits

By using surface coatings and self-lubricating seals, the process air path is completely free of oil. Some advantages of an oil-less compressor are:

- Reduced compressor maintenance
  - Oil-less compressors still require maintenance, but there is no need to worry about oil leaking out and requiring frequent checks and replenishment
- No risk of oil fires associated with oiled compressor technologies
- Extended dryer desiccant cartridge life
  - Eliminating oil from the compressed air path eliminates dryer desiccant fouling due to compressor oil

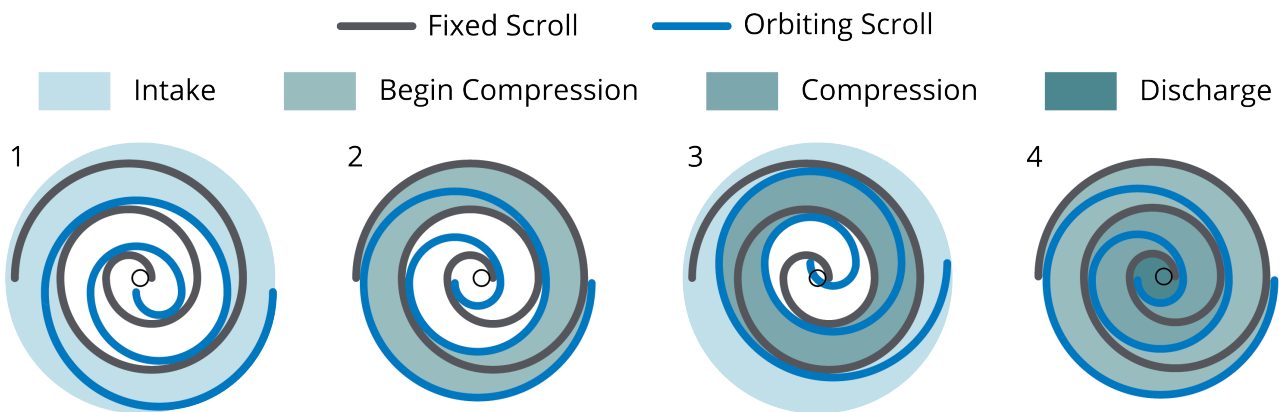

Figure 1: Scroll Compression Cycle

### 1.3 Terminology

**Air end** – mechanical component of the air compressor which does the work of compressing air. May also be referred to as the pump.

**Aftercooler** – heat exchanger used to remove heat from compressed air.

**Compressor** - The entire unit including the pump, motor, aftercooler, baseplate, plumbing, and anything else that is a part of the unit.

**Direct Coupled** – Air end and motor coupled via an in-line torsional coupling

**Fixed Scroll (FS)** – cast aluminum component of the air end which is comprised of scroll wraps and cooling fins which is installed in a fixed position (see Figure 2).

**Ingress Protection (IP) Rating** – a standard guideline to the degree of protection provided by electrical enclosures against intrusion, dust, accidental contact, and water.

**Oil-less** – no oil used anywhere in the machine

**Orbiting Scroll (OS)** - cast aluminum component of the air end which is comprised of scroll wraps and cooling fins which is installed on bearings that allow orbital motion which is caused by an input shaft throw (see Figure 2)

**Pump** – see air end

**PMAC** – Permanent Magnet Alternating Current

**Scroll Wrap** - spiraled wall in the scroll air end (see Figure 3).

**Pressure** - Powerex scroll compressors are available in two pressure ratings:

**Standard Pressure** - 0.8 MPa-G (116 PSI-G)

**High Pressure** - 1.0 MPa-G (145 PSI-G)

**Tip Seal** – PTFE seal that prevents air from escaping the compression pocket as the air is pushed through the scroll. This seal is seated in the groove on top of the scroll wraps. (See Figure 4)

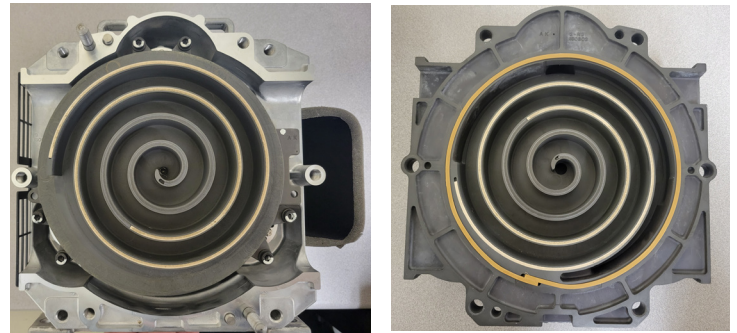

Orbiting Scroll

Fixed Scroll

Figure 2

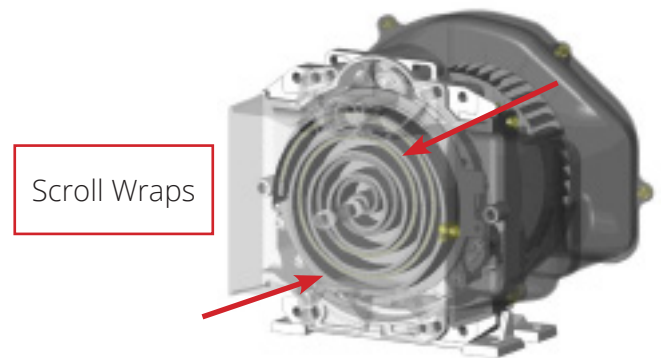

Scroll Wraps

Figure 3



Figure 4

### 1.4 Application Guidelines

#### 1.4.1 Ambient Temperature and Duty Cycle

Powerex Transportation compressors are rated for 100% duty cycle up to 40°C ambient temperature. Ambient temperature is defined as the temperature of the air directly surrounding the air compressor. Above 40°C, it is acceptable to rate in a linear relationship up to the rating of 30% duty cycle at 60°C as shown in Figure 5 below. Powerex recommends that the vehicle designer analyze and test to verify that these conditions are met to ensure reliable compressor operation.

$$\text{duty cycle \%} = -\frac{1}{2} (\text{Temp } ^\circ\text{C}) + 240$$

Equation 1: Duty Cycle Calculation Above 40°C and up to 60°C

$$\text{duty cycle \%} = \frac{70}{36} (140 - \text{Temp } ^\circ\text{F}) + 30$$

Equation 2: Duty Cycle Calculation Above 104°F and up to 140°F

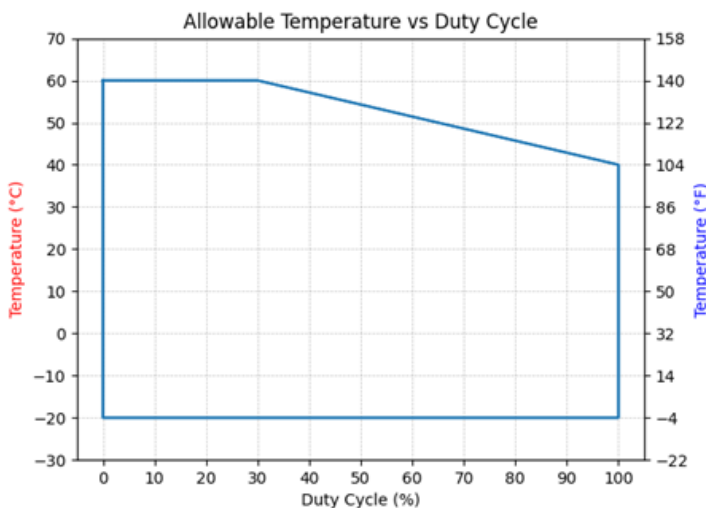

Figure 5: Maximum Temperature at Duty Cycle Limits

Example Duty Cycle and Hourly Runtime Calculation:

Determine the maximum allowable duty cycle at 53°C:

$$\text{duty cycle \%} = -\frac{1}{2} (53 ^\circ\text{C}) + 240 = 54.5\%$$

$$\text{hourly run time} = 54.5\% * 60 \text{ min/hr} = 32.7 \text{ minutes}$$

Therefore at 53°C, the maximum allowable duty cycle is 54.5% and the runtime is not to exceed 32 minutes every hour.

Determine the maximum allowable duty cycle and maximum hourly run time at 125°F:

$$\text{duty cycle \%} = \frac{70}{36} (140 - 125) + 30 = 59.2\%$$

$$\text{hourly run time} = 59.2\% * 60 \text{ min/hr} = 35.5 \text{ minutes}$$

Therefore at 125°F, the maximum allowable duty cycle is 59.2% and the runtime is not to exceed 35 minutes every hour.

#### 1.4.2 Altitude Performance Characteristics

Powerex performance figures are rated up to an altitude of 1,000 m (3,281 ft) above Mean Sea Level. Consultation with Powerex about performance is mandatory **PRIOR TO OPERATION** for operation in elevations above 1,000 m (3,281 ft).

#### 1.4.3 Inlet Air

The process air intake should be located a clean environment, relatively free of dust, salt, debris, liquids, or other contaminants. This helps prevent the pump from ingesting these materials, which can damage the scrolls and lead to pump failure. Additionally, air that is too dirty can prematurely clog the intake filter. An extremely clogged filter, while unlikely to happen, can cause enough intake vacuum to cause pump failure. Some compressor models include a restriction indicator on the intake path that provides a visual signal to indicate this condition without removal of the filter housing lid.

Additionally, for best performance inlet air should be relatively cool. Not only is cooler air less likely to cause wrap damage, but hotter air is less dense than cooler air is. As a result of the decreased density in higher temperatures, compressor mass flow will be reduced when intake air temperature is high. If the compressor is in a location where the temperature is greater than the outside ambient temperature, it may be beneficial to use a snorkel to bring in ambient air that is cooler than the air around the compressor. However, any snorkel design must be approved by Powerex prior to operation.

#### 1.4.4 Compressed Air Plumbing

Discharge lines should be routed such that pooling of liquid water is discouraged. Condensate in the discharge, if allowed to accumulate, can freeze when the compressor is used in cold weather. It is possible for ice to build up enough to create a blockage. Figures 6 and 7 below can be used to give an approximation of how much water will be discharged at 100% duty cycle but are to be used for **REFERENCE ONLY** as they may not reflect actual operational discharge condensation. Note that maximum condensation will occur at 100% humidity at 40°C (104°F) as temperatures above this



require decreasing the duty cycle which will result in less water condensation.

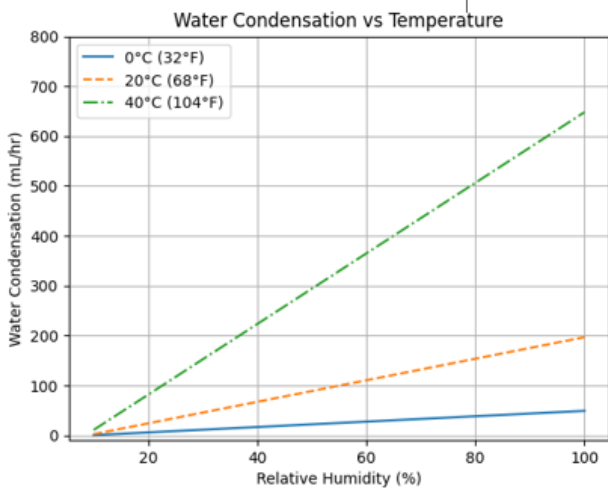

Figure 6: High Pressure Approximate Hourly Water Condensation at Discharge 100% Duty Cycle

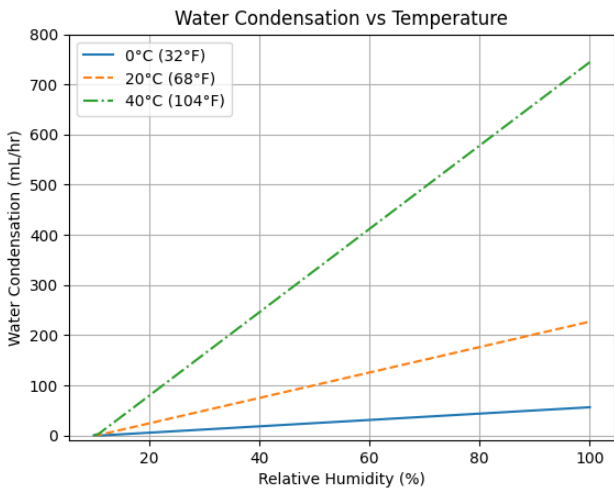

Figure 7: Standard Pressure Approximate Hourly Water Condensation Discharge at 100% Duty Cycle

Systems supplied without an aftercooler require a check valve and ASME pressure relief valve to be installed downstream of the compressor discharge to prevent damage from extended reverse rotation of the compressor and over pressurization due to downstream blockages, respectively.

### 1.4.5 Water Exposure

For a long service life, Powerex recommends installing the compressor in a location that is protected from direct road spray.

3HP PMAC Powerex Compressors are IP54 Rated. This rating must be reviewed and understood by the end user so that they are not violated. Powerex does not recommend use of high-pressure water to clean the compressor.

**NOTICE** This compressor is not designated for immersion in water or for washing with high pressure jets.

### 1.4.6 Maintenance Considerations

Unless removing the compressor to perform standard maintenance is expected, all the procedures in Section 3 of this manual should be reviewed and clearance sufficient for completing those procedures should be provided around the air end portion of the compressor. One example of this is the orbital scroll grease access point called out in Figure 8.



Figure 8

All Powerex maintenance intervals are based on hours of compressor operation. Performing maintenance based on bus hours or miles is not ideal. Powerex strongly recommends that the vehicle OEM monitor and log the time that the compressor operates. This will assist the end user in determining the appropriate time to complete the required compressor maintenance.

If direct measurement of operation time is not possible, compressor operating hours may be estimated as follows:

$$\text{Vehicle Operating Hours} \times \text{Compressor Duty Cycle} = \text{Compressor Operating Hours}$$

To complete this calculation, the vehicle manufacturer may be able to provide the expected duty cycle based on their air system design and testing.

**DISCLAIMER:** Due to variation in vehicle design and use case, the above formula is only an estimation. Without care and diligence in its application, results may or may not be sufficient in determining compressor operating hours. It is the responsibility of the vehicle OEM to provide the end user with a method of correctly determining when a maintenance interval has been reached.

### 1.4.7 Uncrating

Standard crating for Powerex Transportation compressors consists of a plywood crate to protect the compressor during shipping. For best results, the top and all four sides of the crate should be removed prior to removing the compressor. Guidelines for lifting and handling the unit may be found in section 2.1.2.2. The compressor will be mounted to the pallet with bolts to prevent movement during shipping and handling—be sure to remove all compressor to pallet fasteners prior to lifting to avoid damaging the compressor.

**NOTICE** Be sure to remove all compressor to pallet fasteners prior to lifting to avoid damaging the compressor.

Upon receipt of the compressor system, the unit should be inspected for any damage which may have occurred in shipment. Any shipping damage must be immediately filed with the freight carrier. Repair or replace damaged items before use.

**WARNING** Do not operate unit if damaged during shipping, handling, or use. Damage may result in bursting and cause injury or property damage.

**NOTICE** Should you need to return a compressor to Powerex, please be sure to fasten it to the pallet to prevent damage during shipping and handling. Powerex will not be responsible for damages caused by failing to secure or improperly securing a compressor for return shipment.

**NOTICE** When replacing a pump or compressor, all plumbing must be thoroughly cleaned out or replaced. This includes all fittings and hoses on the intake side of the pump up to and including the air filter assembly. It also includes all plumbing and components downstream of the air end (pump), up to and including the nearest check valve. If any debris is left in those areas, the new pump is likely to ingest this debris and fail.

### 1.4.8 System and Major Component Identification

This section highlights the location of key information on the various decals and nameplates found on a Powerex compressor. For the specific locations of these labels, see the System and Major Component Identification Locations in Section 2.1.2.1.

Powerex Model Number

Model No./Modèle No./Modelo No.	RATING	SCFM	Tank Size
SDCHS050020NB03 N100010	5	13.3	N/A
Serial No./No. De Série/No. De Serie			
(M)3/31/2022-S34957-7718			
Wired for/Cablè Pour/Alambrado Por			
230V / 3PH / 60HZ / 11.8			

Customer/Vehicle  
OEM Part Number

System Serial  
Number

Figure 9: Powerex System Spec Decal

**POWEREX**

---

**OILLESS SCROLL COMPRESSOR**

TYPE	SDC016511AV	SERIAL NO	ZH3486
------	-------------	-----------	--------

Powerex Iwata Air Technology Inc. MADE IN JAPAN

Air End Part Number

Air End Serial Number

Figure 10: Air End Nameplate

ABM Greiffenberger Antriebstechnik / www.abm-drives.com

COO: XXXXX CE

Mot Nr	TNr
VDE0530	IKI UT C IP

Motor serial number Motor manufacturer's part number

Typ			
	kW	V	Hz
	A	cos 0,	
	1/min		
BREMSE	TS	Nm	V A CB CA

Figure 11: Motor Nameplate

### 1.4.9 Powerex Transportation Model Numbering

The compressor Model Number contains a variety of information about the compressor. The diagram below shows what each segment of the Model Number indicates.

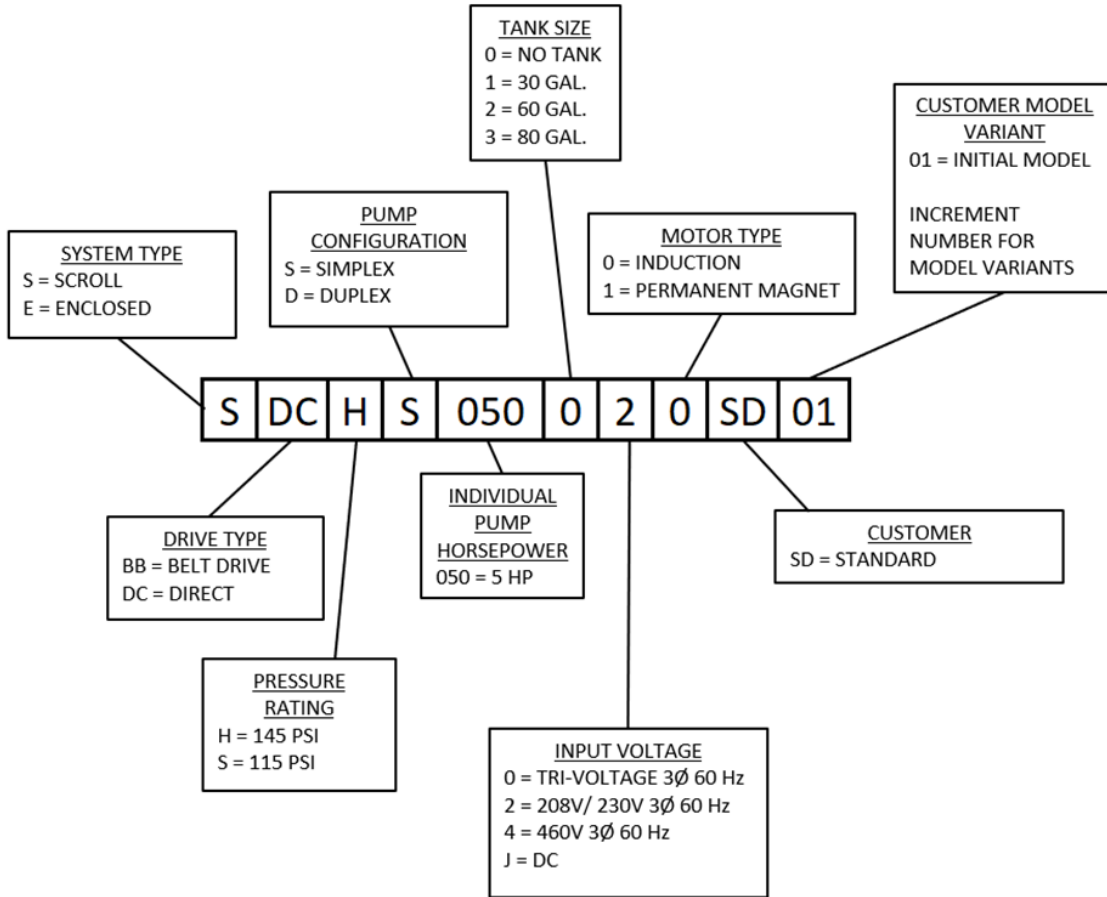

Figure 12

### 1.5 General Performance

Approximate Mass: 54.4 kg (120 lbs)

Max Gauge Pressure:

High Pressure: 1,000 kPa (145 PSI)

Standard Pressure: 800 kPa (116 PSI)

Intake Volumetric Flow Rate:

High Pressure: 200 ± 10 L/min (7.1 ± 0.35 CFM)

Standard Pressure: 235 ± 12 L/min (8.3 ± 0.42 CFM)

## 2. Architecture Specific Information

### 2.1 Scroll Direct Coupled (SDC)

#### 2.1.1 Maintenance Schedule

Table 1 and Table 2 below indicate the maintenance required based on hours of compressor operation. Please refer to Section 1.3.7 or the vehicle OEM for additional information on how to determine the compressor’s operating hours.

Please note that the maintenance intervals vary based on the model of compressor you have. Compare the Powerex Model Number found on the Powerex System Spec Decal (see Figure 9 and Figure 15) to the Powerex Transportation Model Numbering Diagram found in Section 1.4.9. If the Pressure Rating is 1,000 kPa-G (145 PSI-G), follow the intervals in Table 1. If the Pressure Rating is 800 kPa (116 PSI-G), follow the intervals in Table 2.

**Table 1: High Pressure 1,000 kPa-G (145 PSI-G) SDC Compressors**

Item	Action Required	Operating Hours							
		2,500	5,000	7,500	10,000	12,500	15,000	17,500	20,000
Inlet Air Filter	Replace	Δ	Δ	Δ	Δ	Δ	Δ	Δ	Δ
General Inspection	Clean	Δ	Δ	Δ	Δ	Δ	Δ	Δ	Δ
Cooling Fan	Clean		Δ		Δ		Δ		Δ
Fan Duct	Clean		Δ		Δ		Δ		Δ
Scroll Cooling Fins	Clean		Δ		Δ		Δ		Δ
Bearings	Grease		Δ		Δ		Δ		Δ
Tip Seals	Replace		Δ		Δ		Δ		Δ
Check Valve (If equipped)	Replace				Δ				Δ
Heat Insulation Pipe	Replace		Δ		Δ		Δ		Δ
Dive Coupling	Inspect	Δ	Δ	Δ	Δ	Δ	Δ	Δ	Δ

**Table 2: Standard Pressure 800 kPa (116 PSI-G) SDC Compressors**

Item	Action Required	Operating Hours							
		2,500	5,000	7,500	10,000	12,500	15,000	17,500	20,000
Inlet Air Filter	Replace	Δ	Δ	Δ	Δ	Δ	Δ	Δ	Δ
General Inspection	Clean	Δ	Δ	Δ	Δ	Δ	Δ	Δ	Δ
Cooling Fan	Clean		Δ		Δ		Δ		Δ
Fan Duct	Clean		Δ		Δ		Δ		Δ
Scroll Cooling Fins	Clean		Δ		Δ		Δ		Δ
Bearings	Grease				Δ				Δ
Tip Seals	Replace				Δ				Δ
Check Valve (If equipped)	Replace				Δ				Δ
Heat Insulation Pipe	Replace				Δ				Δ
Drive Coupling	Inspect	Δ	Δ	Δ	Δ	Δ	Δ	Δ	Δ

**NOTES:**

1. This maintenance schedule is a standard schedule for Powerex compressors. Vehicle OEM's may work with Powerex to adjust this to be specific to vehicle design, causing minor differences between Powerex and OEM maintenance intervals and instructions. Consult vehicle OEM as needed for clarification.

2. If the air end reaches 3 years and has not yet accumulated the minimum run hours specified in the tables above, perform the greasing operation for the bearings, with the amount of grease reduced by 25%.

### 2.1.2 SDC with PMAC motor

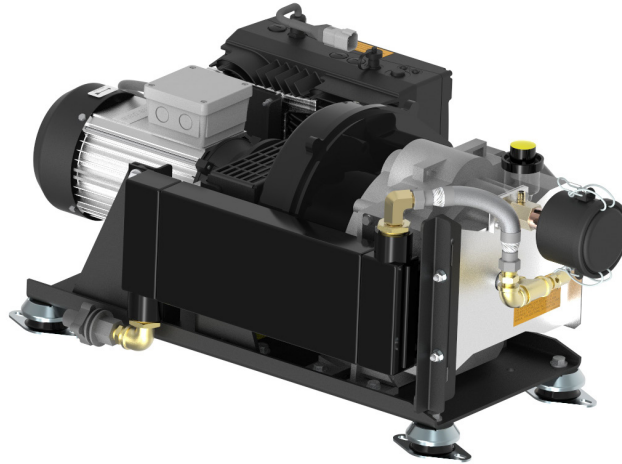

Figure 13: 3HP PMAC Compressor

#### 2.1.2.1 Typical System and Major Component Identification Locations

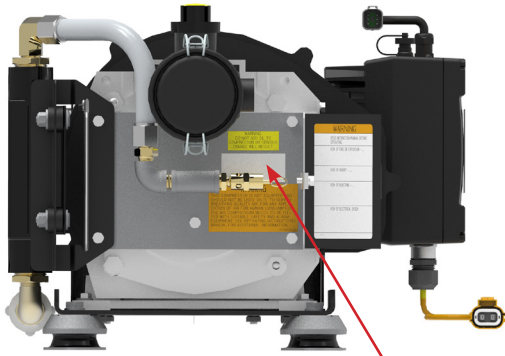

Figure 14

Air End Nameplate

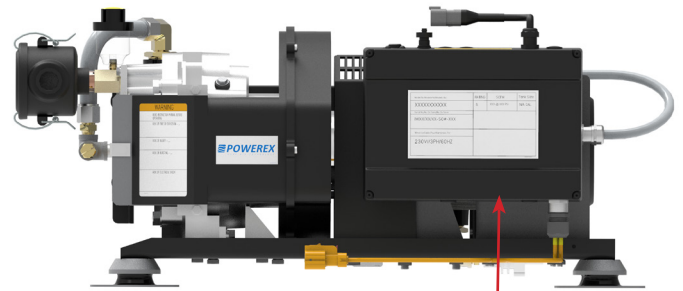

Figure 15

System Spec Decal

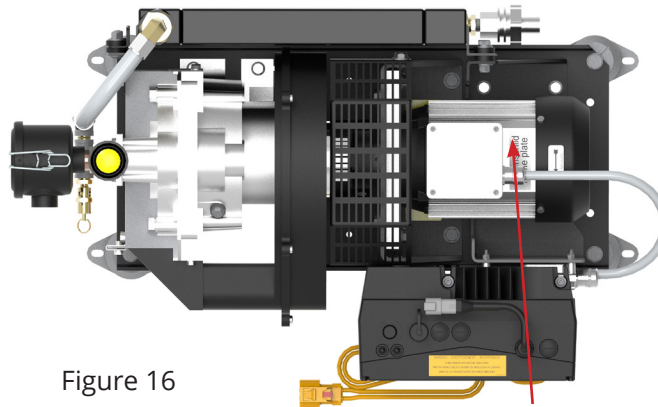

Figure 16

Motor Nameplate

### 2.1.2.2 Lifting / Handling

To lift the PMAC unit out of the shipping crate, please adhere to the following instructions. This will require the use of a mechanical lift, heavy duty industrial straps, and hooks rated appropriately for the system being lifted.

1. Loop a strap around the motor between the motor's junction box and the motor fan shroud.
2. Place a hook through each eyehole on the top of the air end. Alternatively, you can thread a strap through both holes if no hooks are available.
3. Ensure that the four bolts holding the unit to the shipping pallet are removed and proceed to lift the unit out of the crate with caution.

**NOTICE** Be sure to remove all compressor to pallet fasteners prior to lifting to avoid damaging the compressor.

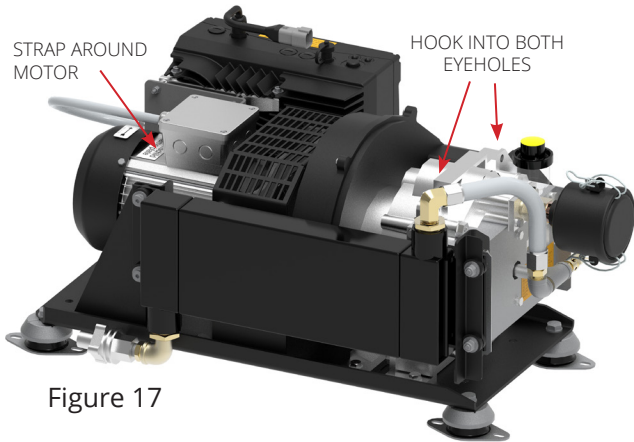

Figure 17

### 2.1.2.3 Motor Replacement Procedure

To replace the motor on a PMAC unit, please adhere to the following instructions. This will require the use of basic hand tools.

**WARNING** To prevent unexpected compressor operation while performing this procedure, perform the appropriate lock out and tag out procedures to isolate the compressor from electric and pneumatic energy sources.

1. Remove the electric connections from the motor.
2. Remove the coupling guard. Loosen the screws that secure the coupling rubber element radially to the drive hubs.

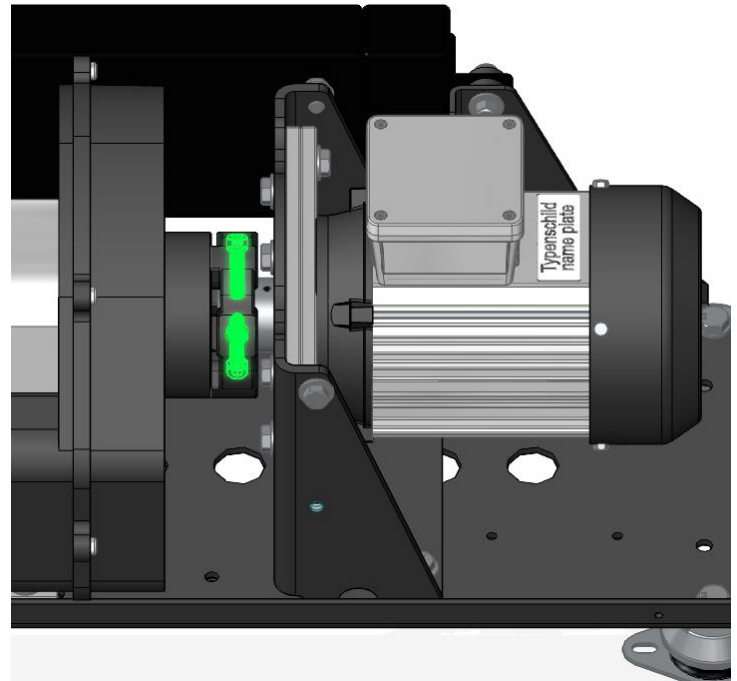

Figure 18: Radial Coupling Bolts

**NOTICE** Do not loosen the set screw that secures the drive hub to the motor shaft.

3. Loosen the hex head screws that hold motor adapter plate 1 to motor adapter plate 2 (see Figure 19). Support the body of the motor so it can be pulled straight back. The drive coupling hub will come free with the motor.

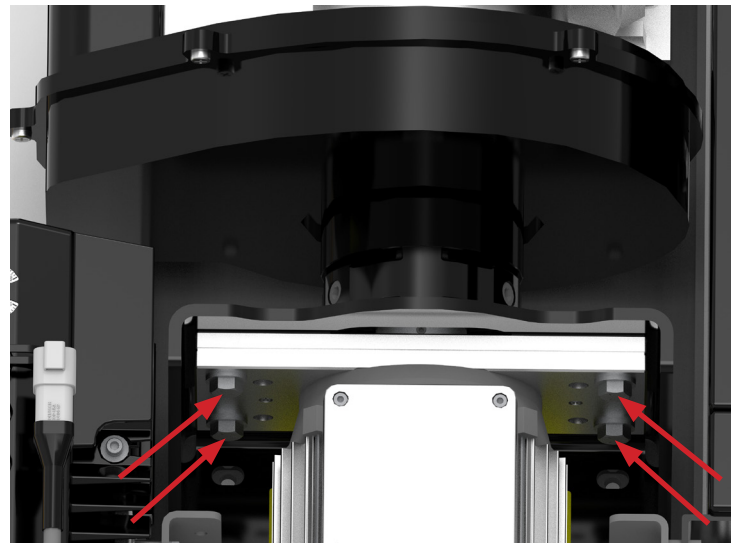

Figure 19: Adapter Plate Bolts

**NOTICE** Do not lose the 2 alignment pins installed in the two motor adapter plates. These pins are required to maintain alignment between the motor and the pump.

**NOTICE** Do not loosen the hex head screws (see Figure 20) that secure motor adapter plate 2 to the motor support bracket.

4. Remove motor adapter plate 1 from the motor by removing the socket head screws that secure the adapter plate to the motor.

5. Measure the position of the drive hub relative to the existing motor shaft. Loosen the setscrew and place the hub on the new motor and position the hub in the same location on the new motor. Make sure the key is in place.

6. Installation is the reverse of removal. Be sure the key is in place on the motor shaft.

7. Install and tighten the set screws into the motor drive hub. Torque to 45 in-lbs.

8. Install and tighten the screws to secure the rubber element to the motor drive hub. Torque to 18 ft-lbs.

9. Reinstall the coupling guard.

10. Reconnect the electric power and verify proper rotation before running the compressor more than a few seconds.

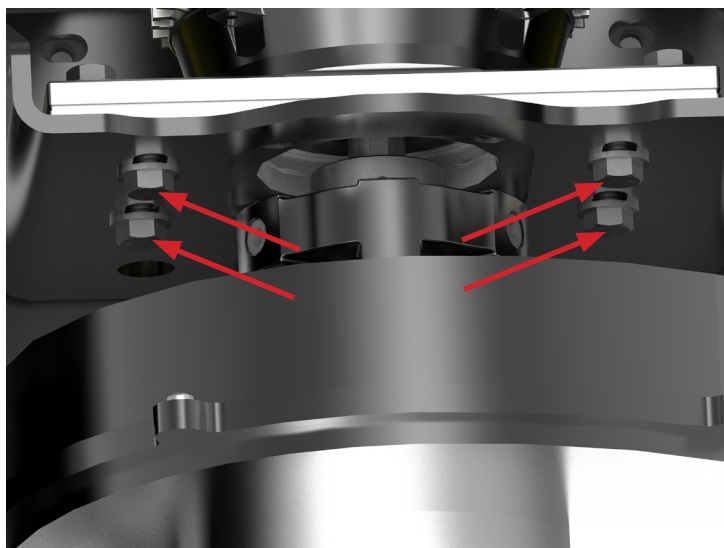





















Figure 20







## 2.1.2.4 Troubleshooting Guide - SDC with PMAC Motor

Problem	Corrective Action
Motor does not run, runs slowly or is excessively noisy	<ol style="list-style-type: none"> <li>1. Check wiring. Ensure all wiring connections are secure.</li> <li>2. Check to make sure motor is not overloaded. Remove coupling and determine if no load operation of motor is correct. Check rotation of pump by hand. It should turn smoothly. If not, check for pump damage or obstruction in the pump.</li> <li>3. Check inverter status lights for indication of error / fault</li> </ol>
Pump is noisy or rough, or puts too much load on the motor	<ol style="list-style-type: none"> <li>1. If current draw (A) and vibration are normal, allow the pump to run for a few minutes and determine if noise diminishes and disappears.</li> <li>2. Check for blockages in downstream plumbing. Remove blockages found.</li> <li>3. Check to make sure that the pump is open to intake air. If isolation valves are used on intake and are accidentally closed when the pump is running, pump damage can occur. This is not covered under warranty. Powerex recommends using a three-way valve if isolation is desired so that no matter the valve position, a path to intake air is always open.</li> <li>4. Inspect Pump Wraps for Chatter Marks. If chatter marks are excessive, the pump needs to be replaced.</li> </ol> <p><b>If the problem persists, please contact Powerex at 1-888-769-7979</b></p>
Current draw (A) is high	<ol style="list-style-type: none"> <li>1. Check wiring. Ensure all wiring connections are secure.</li> <li>2. Check to make sure motor is not overloaded. Check rotation of pump by hand. It should turn smoothly. If not, check for pump damage or obstruction in the pump.</li> </ol>
Excessive vibration	<ol style="list-style-type: none"> <li>1. Check for damage. If the motor shaft becomes bent due to shipping, the mass coupling will be off-center and generate vibration. Replace the motor.</li> <li>2. If the pump is damaged, the fan may rub and cause noise. It is possible to replace just the fan. Contact Powerex at 1-888-769-7979 for instructions.</li> <li>3. Some variation in the vibration profile is normal.</li> <li>4. Dirty fan blades may contribute to unit vibration. See section 3.5 for information on how to clean the fan.</li> <li>5. Missing coupling bolts or damage to the coupling can cause extreme vibration. Inspect the coupling and re-install bolts or coupling as needed.</li> </ol>
Pump rotates in reverse for more than a few seconds when power is off.	<ol style="list-style-type: none"> <li>1. Check valve is leaking, allowing compressed air to vent through the pump. If allowed to continue, pump damage may occur. Replace the check valve.</li> <li>2. Do not use check valve other than Powerex Part IP087700AV.</li> </ol>
Motor runs but no compressed air is produced	<ol style="list-style-type: none"> <li>1. Confirm that the motor is rotating in the correct direction. If not, contact Powerex.</li> <li>2. Perform Coupling Inspection Procedure (2.1.1)</li> <li>3. Check the air filter. If clogged, replace the filter element.</li> <li>4. Inspect the relief valve. If faulty, replace the relief valve.</li> </ol>
Pressure relief valve activation	<ol style="list-style-type: none"> <li>1. Confirm that system pressure is not more than the compressor rating. If the system pressure exceeds compressor rating, review the system controls, and correct them as needed.</li> <li>2. Check downstream plumbing for closed isolation valves, restrictions, or icing. Remove restriction.</li> <li>3. If you have confirmed system pressure does not exceed compressor rating and all plumbing downstream of the pump is clear, replace the relief valve with Powerex part number V-215900AV for high pressure and V-216000AV for standard pressure.</li> </ol>

### 2.1.2.5 Inverter Status Lights

Red LED	Green LED	State
		Boot loader active (flashing in turn)
		Ready for operation (activate En_HW for operation)
		Operation/ready
		Warning
		Error
		Identification of motor data
		Initialization
		Firmware update
		Bus error operation
		Bus error ready for operation

### Legend

	LED off		LED on
	LED flashing		LED flashing quickly

### 3. Scroll Air End Maintenance Procedures

The maintenance procedures in this section are to be performed at the intervals specified in Table 1 or 2 in Section 2 according to the pump type.

#### 3.1 Bearing Lubrication

Before getting started, be sure to have the required tools and supplies listed in the table below.

Required Tools and Supplies	
Part Number	Description
IP616100AV	GREASE GUN
92583130	GREASE GUN NOZZLE
IP600000AV	GREASE-POWEREX SCROLL 80gm



Figure 21: Grease, grease gun, and nozzle required

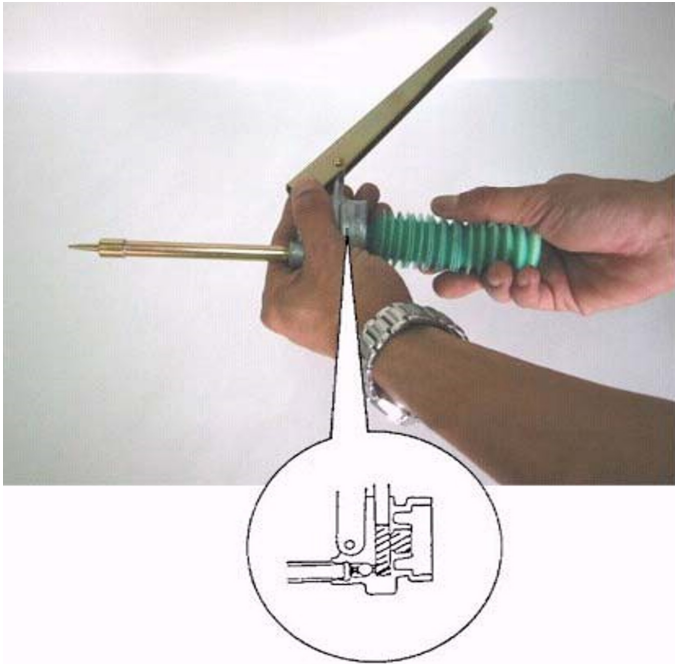

Figure 22: Installing the grease cartridge

NOTE: The Grease Gun Nozzle does not come installed and must be screwed into the gun.

To complete the grease gun assembly:

1. Remove the metal canister from the grease gun.
2. Remove the cap from the grease cartridge.
3. Screw the grease cartridge into the grease gun as shown in Figure 22.
4. Screw the metal canister back onto the gun, covering the grease cartridge.
5. Pump the grease gun to purge the air out of the nozzle.

**NOTICE** Only use Powerex genuine grease.

The Powerex Scroll Air End has 4 greaseable bearings: 1 orbital scroll (OS) bearing and 3 pin crank bearings. Please follow the steps in the sections below to complete this greasing at the intervals specified in Table 1 and 2 in Section 2.

### 3.1.1 OS Bearing Lubrication

**WARNING** To prevent unexpected compressor operation while performing this procedure, perform the appropriate lock out and tag out procedures to isolate the compressor from electric and pneumatic energy sources.

1. Remove the ribbed plug from the grease access port. Figure 23 shows the standard access port location

on all Powerex 5HP scroll air ends.

2. Rotate the air end shaft by rotating the coupling until the grease fitting is visible through the grease access hole as shown in Figure 24. To avoid having to remove the SDC coupling guard, a screwdriver may be used to turn the coupling as shown in Figure 25.



Figure 23



Figure 24: View of the grease fitting through the grease access hole when rotated into the correct position for greasing

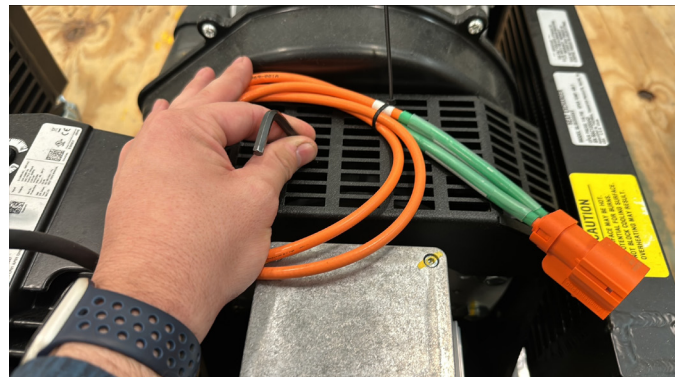

Figure 25: Insert Allen Key or Screwdriver between finger guard to Rotate the Shaft

3. Insert the nozzle of the grease gun through the access hole as shown in Figure 26.

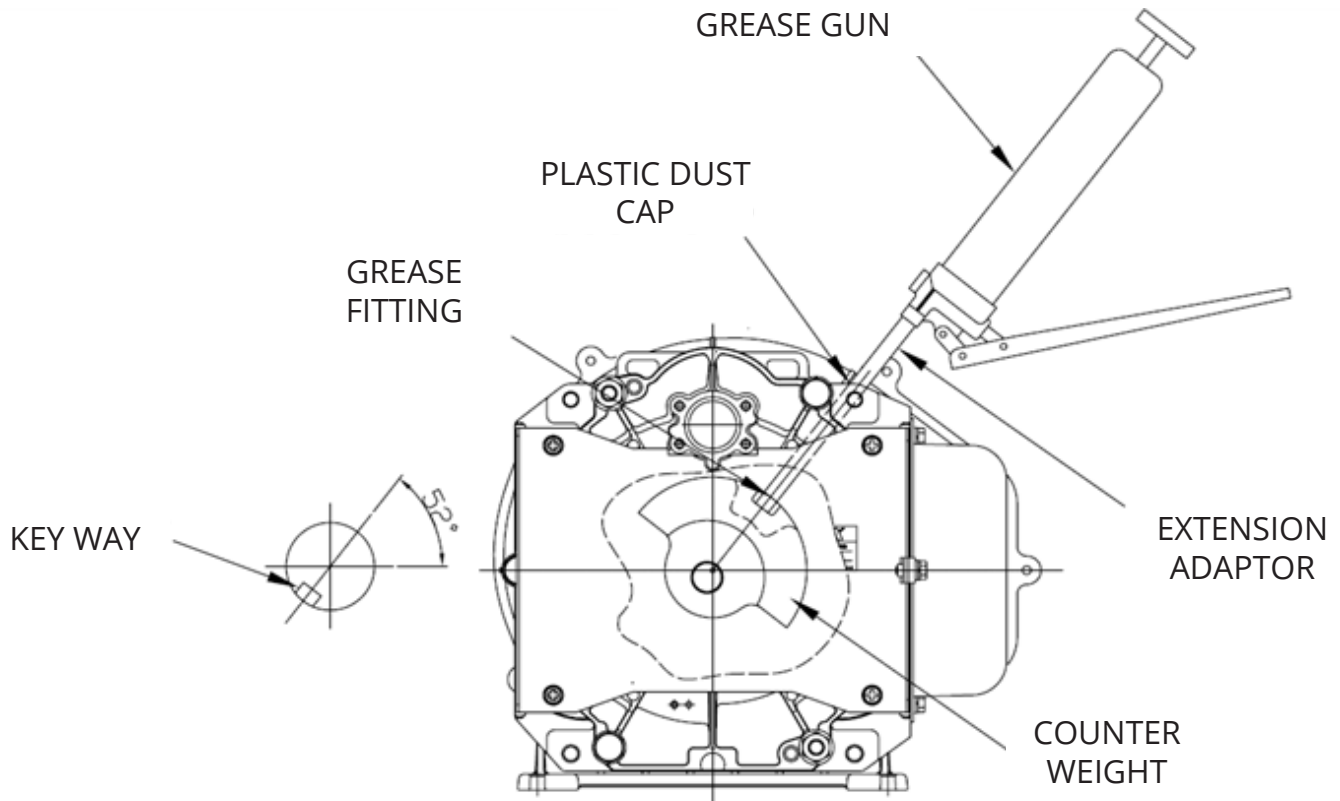

Figure 26: Grease gun insertion for standard access port. For units with the optional second access hole, the grease gun will be inserted the same way but through the second access hole

While holding the nozzle firmly against the grease fitting, pump the grease gun to deliver the appropriate amount of grease for the standard service interval specified in Tables 1 and 2 found in Section 2. For the orbital scroll bearing, pump the grease gun 5 times for the first greasing and 4 times for every other greasing. For the pin crank bearings on the orbital scroll, pump the grease gun 4 times.

**NOTICE** If you are following an increased greasing frequency specified by the vehicle OEM, be sure to only apply the number of pumps of grease specified by their instructions. Overfilling the bearing with grease can damage the seals which hold the grease in the bearing.

**NOTICE** Only use Powerex genuine grease. Make sure to purge the air out of the grease gun and nozzle prior to performing the greasing procedure.

4. Once greasing is complete, remove the grease gun and re-install the ribbed plug.

### 3.1.2 Pin Crank Bearing Lubrication

**⚠️WARNING** To prevent unexpected compressor operation while performing this procedure, perform the appropriate lock out and tag out procedures to isolate the compressor from electric and pneumatic energy sources.

1. Remove the fasteners and hose connection circled in red in Figure 27 and Figure 28. This will allow the aftercooler to be separated from the compressor.

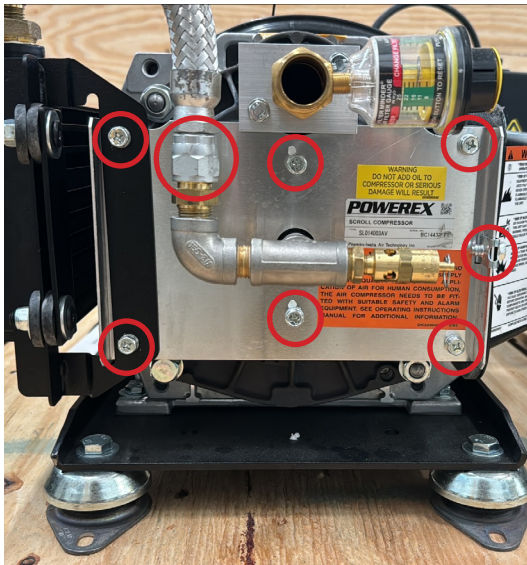

Figure 27



Figure 28

2. Remove the 2 nuts and 2 bolts in Figure 29, and remove the fixed scroll and expose the orbital scroll.



Figure 29

3. Now that the Orbital Scroll (OS) is exposed, the 3 pin crank grease fittings may be accessed as shown in Figure 30.

**NOTICE** Only use Powerex genuine grease. Make sure to purge the air out of the grease gun and nozzle prior to performing the greasing procedure.

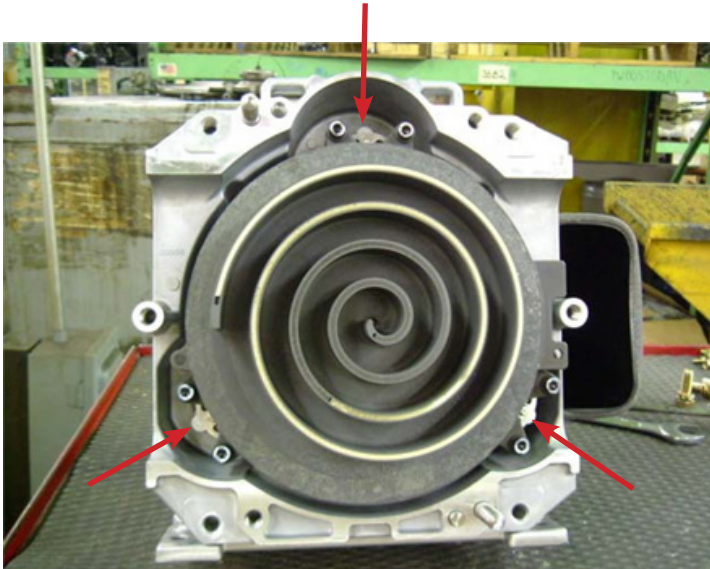

Figure 30: Pin Crank Bearing Grease Fittings

4. Using the grease gun, pump the appropriate amount of grease into each fitting according to Table 5.

Table 5

Pin Crank Bearing Grease	
Air End Part Number	Number of Grease Gun Pumps
SL014003AV	4

5. Re-install the FS. Install the bolts and nuts finger tight and confirm that the crankshaft rotates smoothly by hand.

6. Torque the FS fasteners (see Figure 29) in two stages:

- a. 2 Nm (18 in-lbf).
- b. 30 Nm (266 in-lbf).

NOTE: Assemble so that dust seal and tip seal will not drop between the OS and FS.

7. Re-install the fan duct and aftercooler with the fasteners shown in Figure 27 and 28.

### 3.2 Tip Seal Replacement

To replace the tip seals, the appropriate tip seal set will need to be acquired. Table 6 lists the Air End part number and the corresponding tip seal set part number.

Table 6

Tip Seal Sets	
Air End Part Number	Tip Seal Set Part Number
SL014003AV	2834090

Confirm all parts are present in the tip seal set.

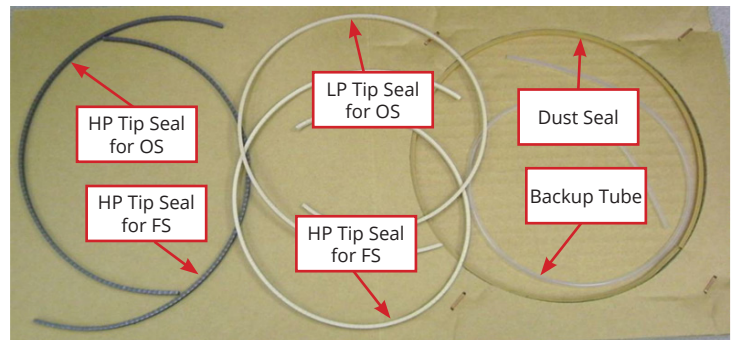

Figure 31: Parts included in Tip Seal Set. HP and LP indicate these seals are for the High Pressure and Low Pressure segments within the scroll, respectively.

**WARNING** To prevent unexpected compressor operation while performing this procedure, perform the appropriate lock out and tag out procedures to isolate the compressor from electric and pneumatic energy sources.

1. To gain access to the tip seals, perform steps 1 and 2 from Section 3.1.2.

2. With the FS removed, use the tip of a ball-point pen to lift the end of the LP Tip Seal out of the FS (see Figure 32). Continue lifting and pulling until the seal is removed.



Figure 32: LP Tip Seal Removal

3. Repeat for the HP Tip Seal, dust seal, and back-up tube.



Figure 33: HP Tip Seal Removal



Figure 34: Dust Seal Removal



Figure 35: Back-up Tube Removal

4. Repeat this process to remove the LP and HP Tip Seals from the OS.

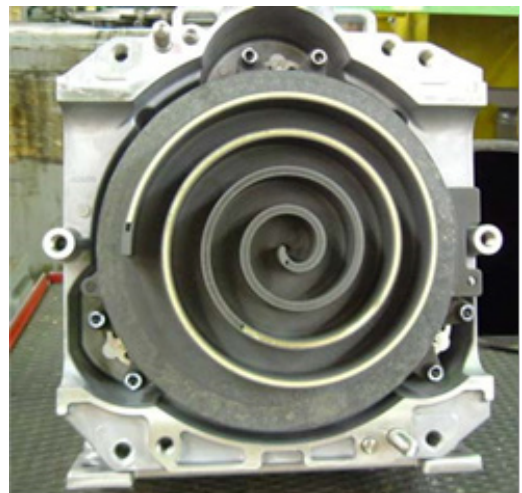

Figure 36: OS. OS acts as mating surface for the dust seal in the FS. The OS does not contain a dust seal.



5. Remove dust from both the OS and FS using a clean cloth or compressed air.

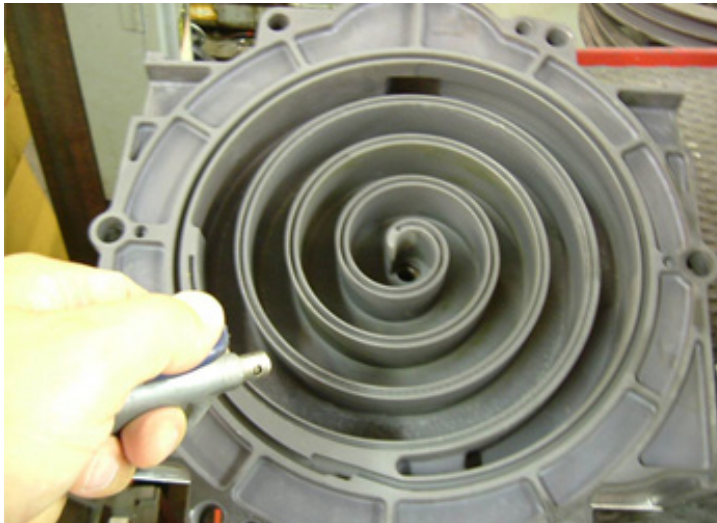

Figure 37: Using an air nozzle to remove dust from FS.

6. Insert new HP Tip Seal from the center section of OS so that there will be no clearance at the start section.



Figure 38: Begin insertion of the HP Tip Seal at the center of the scroll.

**NOTICE** The Tip Seals have directional lip seals that seal to the groove. Tip Seals for OS and FS have opposing seal cut angles. Insert Tip Seal so that the lip seal on the bottom of seal groove and inner side of scroll spiral and the direction of lip faces the center of scroll spiral. This is to be done both OS and FS sets, otherwise the scrolls will not seal, and performance will be degraded.

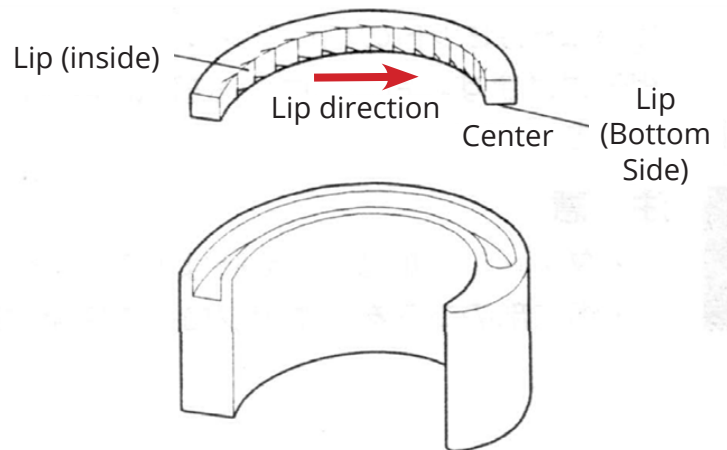

Figure 39: Make sure that the tips of the lips on the Tip Seals point toward the starting point at the center of the scroll.

7. Insert the LP Tip Seal with the end butted up against the HP Tip Seal previously installed in the scroll groove.



Figure 40: Butt the LP Tip Seal up against the HP Tip Seal. Be sure the lip seal tips are pointed in the correct direction.

8. Insert approximately half of the LP Tip Seal and then remove the Tip Seal to confirm that a notch in the Tip Seal has been created. This will prevent movement during compressor operation. Before reinserting, remove any remaining debris around the notch.

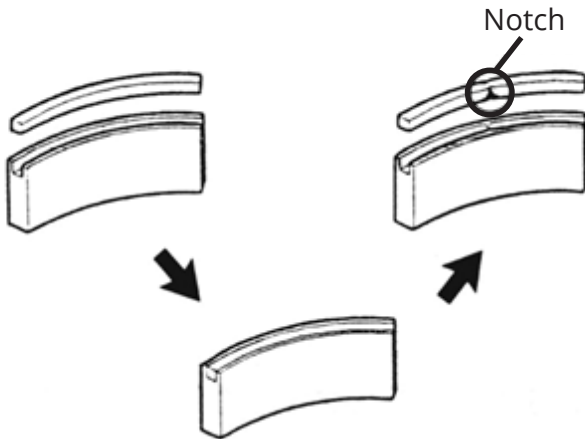

Figure 41: When the LP Tip Seal is installed a notch is created to prevent it from moving in the groove.

9. Continue seating the LP tip seal in the groove. At the end there will be excess. Trim the excess seal off even with the end of the groove and finish seating the seal.



Figure 42

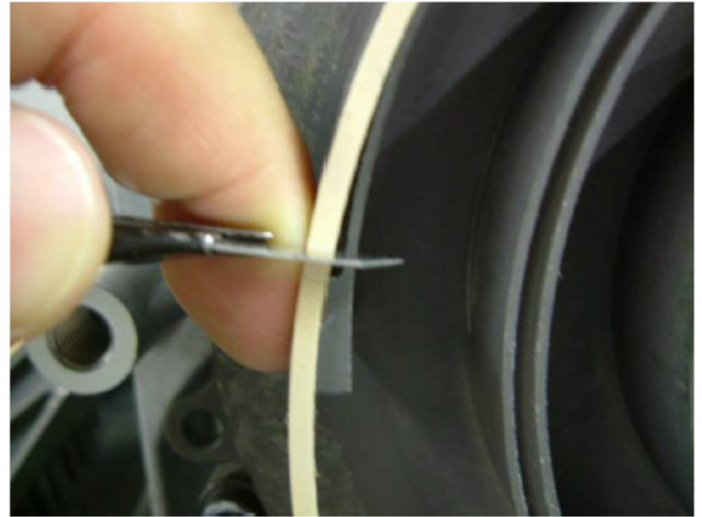

Figure 43: Trim off the excess seal even with the end of the groove.

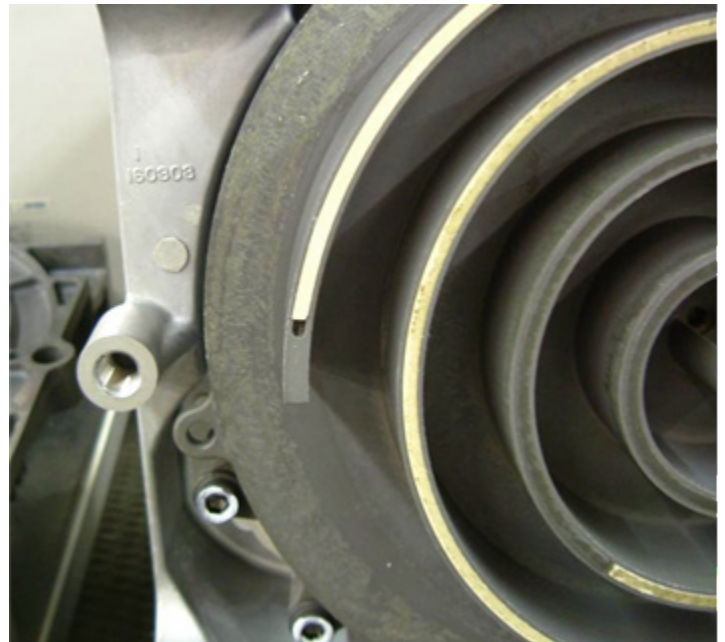

Figure 44: Seat the trimmed seal.

10. Repeat steps 6 through 11 for the FS Tip Seal set.

11. Insert new Backup Tube in the FS, then insert new Dust Seal on the Backup Tube.

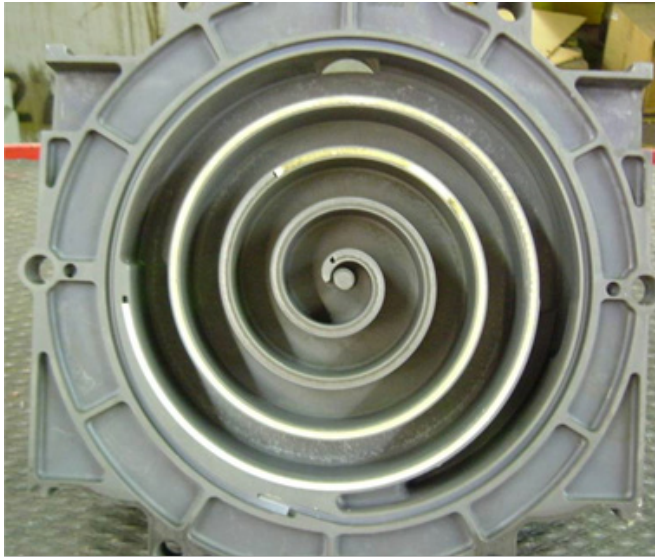

Figure 45: Install back-up tube in outermost groove.

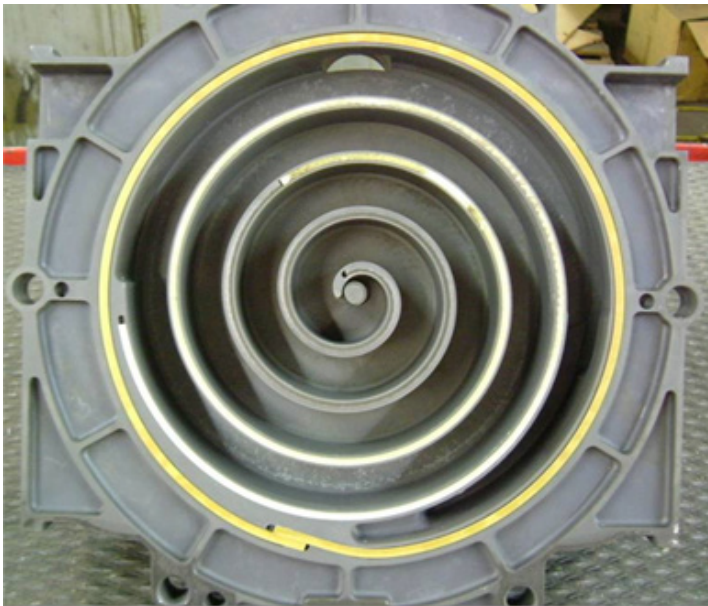

Figure 46: Install dust seal on top of the back-up tube.

12. Re-install the FS. Install the bolts and nuts finger tight and confirm that the crankshaft rotates smoothly by hand.

13. Torque the FS fasteners (see Figure 29) in two stages:

- a. 2 Nm (17 in-lb).
- b. 30 Nm (265 in-lb).

NOTE: Take care so that the dust seals and tip seals do not drop between the OS and FS during re-assembly as that may damage the seals.

14. Re-install the fan duct and aftercooler with the fasteners shown in Figures 27 and 28.

### 3.3 Insulation Tube Replacement

Before performing this procedure, obtain a new insulation pipe Powerex Part Number IP602000AV.

1. Locate the discharge pipe and disconnect any additional plumbing that will prevent removal of the discharge pipe.

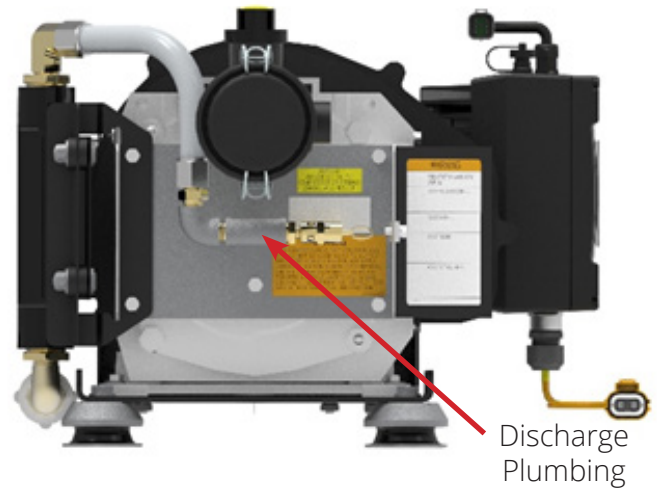

Figure 47

2. Unscrew the discharge pipe.



Discharge Pipe

Figure 48



Figure 49

3. Remove and discard the old insulation tube.



Figure 50: Insulation tube on the left.

4. Replace the thread tape on the discharge pipe.
5. Install the new insulation tube.
6. Re-install the discharge pipe. Tighten finger tight plus half a turn. Re-install any additional plumbing that was removed.

**NOTICE** Over-tightening the discharge tube when reinstalling will damage the pump.

### 3.4 Fin Cleaning

**WARNING** To prevent unexpected compressor operation while performing this procedure, perform the appropriate lock out and tag out procedures to isolate the compressor from electric and pneumatic energy sources.

1. Remove any discharge plumbing that will prevent the removal of the FS cover.
2. Remove the FS cover by removing the 7 fasteners shown in Figure 51.

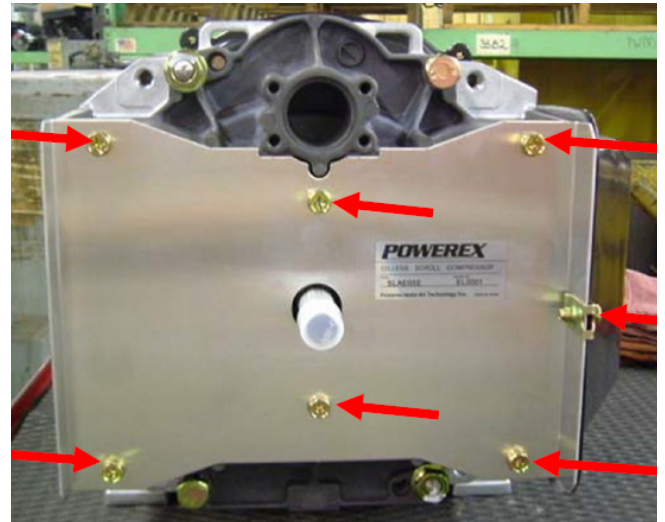

Figure 51: FS cover fasteners



Figure 52: Fixed scroll with fins exposed

3. Cover the discharge tube opening. Using compressed air or a brush, remove all dust and debris from the fins.

NOTE: Failure to properly clean the fins may lead to the air end overheating and premature air end failure.



Figure 53 : Using compressed air to remove debris from the fins.

4. Reinstall the FS cover and any discharge plumbing that was removed.

### 3.5 Cooling Fan Cleaning

**⚠️WARNING** To prevent unexpected compressor operation while performing this procedure, perform the appropriate lock out and tag out procedures to isolate the compressor from electric and pneumatic energy sources.

1. Remove aftercooler, if equipped.
2. Remove the coupling guard.
3. Remove the 5 screws that hold the fan shroud together.

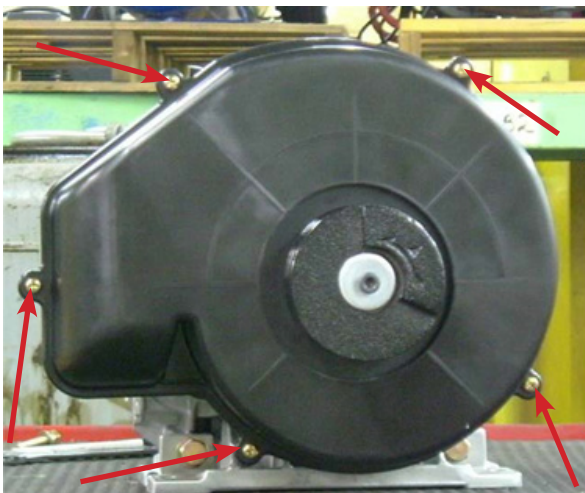

Figure 54: Fan Shroud Screws

4. Slide the fan shroud apart until the fan is visible. Be careful not to damage the shroud.



Figure 55: Fan Shroud opened for cleaning

5. Use compressed air or a brush remove any dust buildup from the fan blades. Rotate the fan by hand to access all of the blades.

NOTE: Failure to properly clean the fan may lead to excess vibration, air end overheating, and premature air end failure.



Figure 56: Using compressed air to remove dust from the cooling fan.

6. Wipe dust and dirt out of the shroud and duct.
7. Reassemble the shroud.
8. Re-install the coupling guard and aftercooler (if equipped).

### 3.6 Filter Replacement

The following sections list some typical filter assemblies provided with Powerex transportation compressors and specifies what is needed to service them. When performing any filter service, clean the housing and inspect it for damage or corrosion which might compromise the function of the filter assembly.

Some systems may not include a filter if the vehicle manufacturer integrated the compressor air source into another filtered air system. Powerex recommends 2-micron particulate filters be used if not using a Powerex supplied filter assembly.

#### 3.6.1. Filter Assembly VP000542AV

To service this filter assembly, purchase service kit VP000558AJ which includes a replacement element, the lid to housing O-ring, and the lip seal which seals the element to the housing. All of these items should be replaced when the element is replaced to prevent debris by-passing the filter element.



Figure 57: Filter Assembly VP000542AV



Figure 58: VP000542AV Air Filter Assembly with top removed



Figure 59: Serviceable parts for VP000542A. The highlighted parts come with the VP000558AJ service kit.

### 3.7 Drive Coupling Inspection

There are two set screws that hold the coupling in place. It is necessary to inspect these screws at regular maintenance intervals in order to make sure that they are sufficiently securing the coupling to the motor shaft. The procedure to do this is specified here:

**⚠️WARNING** To prevent unexpected compressor operation while performing this procedure, perform the appropriate lock out and tag out procedures to isolate the compressor from electric and pneumatic energy sources.

**⚠️WARNING** Turn the compressor off and if able, disconnect any potential power source.

1. Using a ½-inch wrench, loosen and remove the bolts that attach the inverter mounting bracket to the baseplate (see Figure 60). Set the inverter off to the side, taking care to ensure that the slack in the chord connecting the motor to the inverter is not completely taken out. Save the bolts, as you will need them to re-assemble the unit.

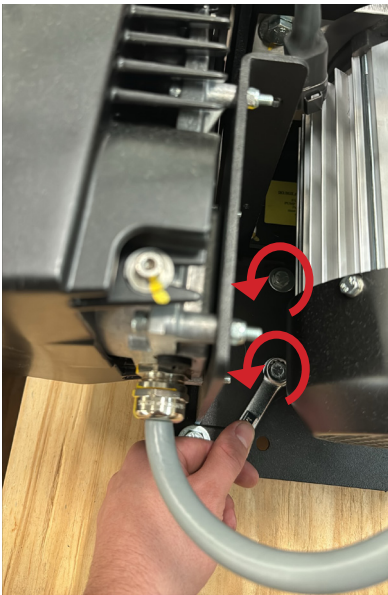

Figure 60

2. Using a ½-inch wrench, loosen and remove the two bolts that attach the aftercooler mounting bracket to the baseplate as shown in Figure 61. Save the bolts, as you will need them to re-assemble the unit.

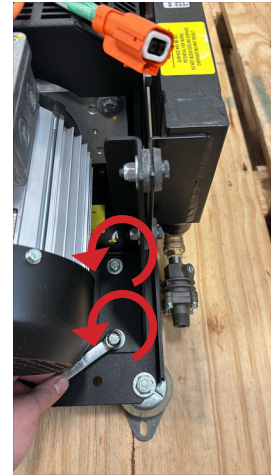

Figure 61

3. Using a ⅜" wrench, loosen the 3 bolts that attach the coupling guard to the motor mounting bracket, as shown in Figures 62 and 63. Do not move the aftercooler more than is shown in this photo as doing so will permanently deform the other aftercooler mounting bracket. Save the bolts, as you will need them to re-assemble the unit.

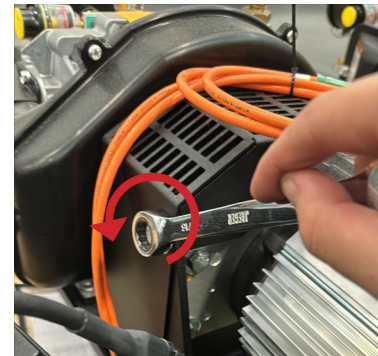

Figure 62

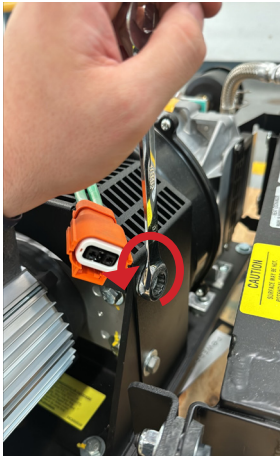

Figure 63

4. Remove the coupling guard.



Figure 64

5. Inspect the metal hub of the coupling to see if you can see both set screws are installed.

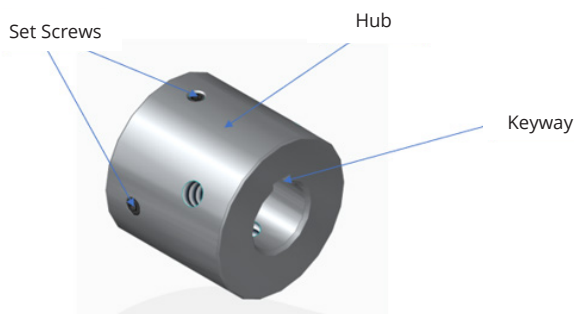

Figure 65

6. If set screws are in place, skip this step.

- If one or both set screws are not in place, install replacement set screws where needed. The screw must be a 10 mm Black-Oxide Alloy Steel M5 cup-point

headless set screw. McMaster-Carr part number 91385A413 or equivalent will be an adequate replacement.

- Upon installation, apply Loctite 243 (or equivalent) to the set screw, then install and torque set screw to 45 in-lbf (5.1 Nm).

7. Attempt to slide the coupling back and forth along the motor shaft's axis. Ensure that it does not slide back and forth.

- If the coupling slides, make sure that the set screws are tightened to 45 in-lbf (5.1 Nm). If the set screws are adequately torqued and the coupling still will not secure, contact Powerex and do not resume using compressor until the issue is resolved.

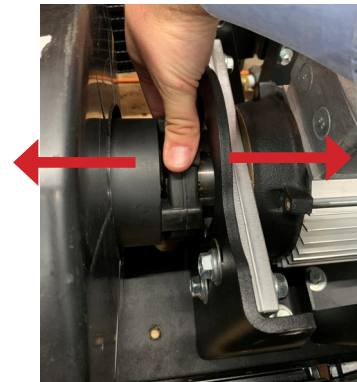

Figure 66

8. Re-attach the coupling guard. Apply Loctite 243 (or equivalent) to the 3 bolts that attach the coupling guard to the motor mounting bracket (refer to Figures 62 and 63) and torque to 8 ft-lbf (10.8 Nm). Do not overtighten as overtightening will deform the coupling guard.

9. Re-attach the aftercooler mounting bracket to the baseplate (refer to Figure 61). Apply Loctite 243 (or equivalent) to the 2 bolts that attach the aftercooler mounting bracket to the baseplate and torque to 13 ft-lbf (17.6 Nm).

10. Re-attach the inverter mounting bracket to the baseplate (see Figure 60). Apply Loctite 243 (or equivalent) to the 2 bolts that attach the inverter mounting bracket to the baseplate and torque to 13 ft-lbf (17.6 Nm).



### 3.8 General Inspection

When replacing the air filter, the compressor should be inspected for the following:

#### 1. Loose fasteners

Visually check for gaps under bolt heads or washers as well as loose components.

#### 2. Corrosion

Visually check for collection of debris on the unit which may retain moisture and cause corrosion. Use a brush or compressed air to remove the debris. If excessive corrosion is found, replace the corroded component.

#### 3. Damage

Considering these units may be mounted in a variety of locations on a vehicle, potential damage from falling objects or road debris must be considered. Inspect the unit to make sure that no components have been cracked, bent, or broken since the last inspection or installation.

#### 4. Coupling Inspection (SDC units only)

Inspect the motor to air end coupling.

A. Confirm that all setscrews are present and secure in the metal hub attached to the motor shaft.

B. Confirm all 6 bolts attaching the rubber element to the motor hub and the air end hub are still in place and torque markings are still aligned indicating that they remain secure.

C. Inspect the rubber element for cracks and loss of rubber adhesion to the metal inserts inside the element. If a crack deeper than 1.5 mm is found or if the rubber-to-metal connections have come loose, the rubber element should be replaced. Figure 67 below shows typical rubber element wear zones. Pressure folds (creasing) in these zones may be considered normal.

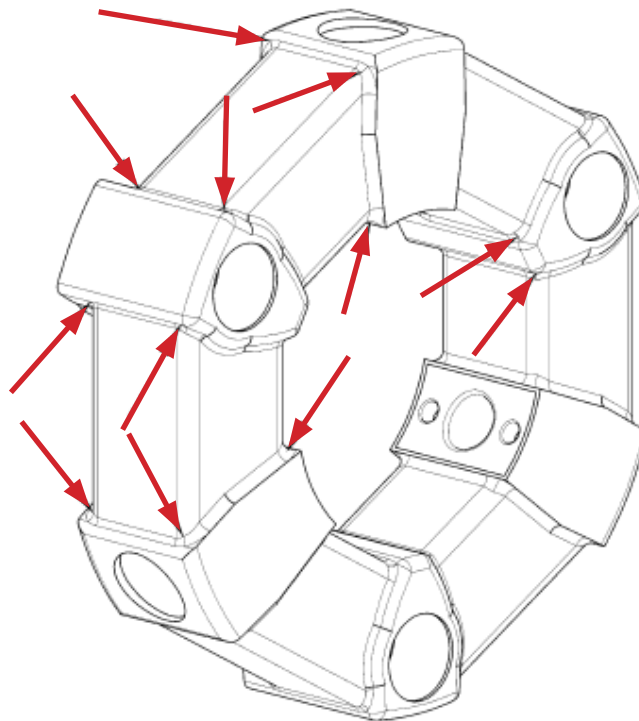

Figure 67: Examples of wear zones on the rubber element indicated by arrows

## 4. Powerex Limited Warranty - Applicable to OEM Customers Only

### Warranty and Remedies.

**(a) General.** Powerex warrants each Compressor System, Vacuum System, Vacuum Pump, Compressor Air-End, or Powerex branded Accessory (collectively "Products", individually each a "Product") to be free from defects in material and workmanship ("Defects") at the date of shipment. This warranty shall apply only to Products that are purchased by Original Equipment Manufacturers (OEMs) and the applications for which are approved in advance in writing by Powerex's Director of Engineering. If the applications for the Products are not approved in advance in writing by Powerex's Director of Engineering then Powerex makes no warranties regarding the Products. EXCEPT AS SET FORTH BELOW, NO OTHER WARRANTY, WHETHER EXPRESS OR IMPLIED, INCLUDING ANY WARRANTY OF MERCHANTABILITY OR FITNESS FOR A PARTICULAR PURPOSE, SHALL EXIST IN CONNECTION WITH THE SALE OR USE OF SUCH PRODUCTS. TO THE EXTENT PERMITTED BY LAW, ANY AND ALL IMPLIED WARRANTIES ARE EXCLUDED. All warranty claims must be made in writing and delivered to Powerex in accordance with the procedures set forth on its website ([www.powerexinc.com](http://www.powerexinc.com)), or such claim shall be barred. Upon timely receipt of a warranty claim, Powerex shall inspect the Product claimed to have a Defect, and Powerex shall replace any Product which it determines to have had a Defect; provided, however, that Powerex may elect, upon return of the Product, to refund to buyer any part of the purchase price of such Products paid to Powerex. In no circumstances will Powerex be required or obligated to pay for labor costs to repair any Defect. Freight for returning Products to Powerex for inspection or for shipping warranty parts shall be paid by buyer where permitted by applicable law. Powerex is not responsible for any import fees, taxes, duties, licenses or other fees imposed by any governmental authority upon the production, sale, shipment and/or use of Products covered hereunder. The warranties and remedies herein are the sole and exclusive remedy for any breach of warranty or for any other claim based on any Defect, or non-performance of the Products, whether based upon contract, warranty or negligence.

**(b) (i) Standard Period of Warranty – Parts Only (No Labor)** - The purchase of any system includes Powerex's standard warranty. Powerex warrants and represents all Products shall be free from Defects for the first eighteen (18) months from the date of shipment by Powerex, or twelve (12) months from the documented date of startup, or five thousand (5,000) hours of use, whichever occurs first. During such warranty period, Powerex shall be liable for all Defects in the Products (the "Product Defects"). Supplier's repair or replacement of any Product shall not extend the period of any warranty of any Product. This warranty applies to the exchange of part(s) found to be defective by an Authorized Powerex Service Representative only.

**(b) (ii) Premium Period of Warranty – Parts Only (No Labor).** In order to be eligible for premium warranty coverage, a premium warranty for each system must be purchased when order is placed. Powerex warrants and represents all Products shall be free from Defects for the first thirty (30) months from the date of shipment by Powerex, or twenty-four (24) months from the documented date of startup, or seven thousand five hundred (7,500) hours of use, whichever occurs first. During such warranty period, Powerex shall be liable for all Defects in the Products (the "Product Defects"). Supplier's repair or replacement of any Product shall not extend the period of any warranty of any Product. This warranty applies to the exchange of part(s) found to be defective by an Authorized Powerex Service Representative only.

**(c) Replacement Pumps – Parts Only (No Labor).** For any replacement Air-End or Vacuum Pumps installed on a Powerex manufactured system or unit after any initial warranty period has expired or where another warranty does not apply for any reason, Powerex warrants that the Air-End or Vacuum Pumps shall be free of Defects for a period of twelve (12) months from the date of shipment by Powerex or five thousand (5,000) hours of use, whichever comes first.

**(d) Replacement Motor - Parts Only (No Labor).** For any replacement motor installed on a Powerex manufactured system or unit after any initial warranty period has expired or where another warranty does not apply for any reason, Powerex warrants that the replacement motor shall be free of Defects for the first twelve (12)

months from the date of shipment by Powerex. For any replacement motor installed on a system or unit that was not manufactured by Powerex after any initial warranty period has expired or where another warranty does not apply for any reason, Powerex warrants that the replacement motor shall be free of Defects for the first ninety (90) days from the date of shipment by Powerex. Supplier's repair or replacement of any Product shall not extend the period of any warranty of any Product. This warranty applies to the exchange of part(s) found to be defective by an Authorized Powerex Service Representative only.

**(e) Replacement Parts – Parts Only (No Labor).** For other replacement parts besides motors, Air-End or Vacuum Pumps installed on a Powerex manufactured system or unit after any initial warranty period has expired or where another warranty does not apply for any reason, Powerex warrants that such replacement parts will be free from Defects for the first twelve (12) months from the date of shipment by Powerex. For other replacement parts besides motors, Air-End or Vacuum Pumps installed on a system or unit that was not manufactured by Powerex after any initial warranty period has expired or where another warranty does not apply for any reason, Powerex makes no warranties. Supplier's repair or replacement of any Product shall not extend the period of any warranty of any Product. This warranty applies to the exchange of part(s) found to be defective by an Authorized Powerex Service Representative only.

**(f) Coverage.** The warranty provided herein applies to Powerex manufactured units or systems only.

**(g) Exceptions.** Notwithstanding anything to the contrary herein, Powerex shall have no warranty obligations with respect to Products:

- (i) That have not been installed in accordance with Powerex's written specifications and instructions;
- (ii) That have not been maintained in accordance with Powerex's written instructions;
- (iii) That have been materially modified without the prior written approval of Powerex; or
- (iv) That experience failures resulting from operation, either intentional or otherwise, in excess of rated capacities or in an otherwise improper manner.

**(h)** The warranty provided herein shall not apply to: (i) any defects arising from corrosion, abrasion, use of insoluble lubricants, or negligent attendance to or faulty operation of the Products; (ii) ordinary wear and tear of the Products; or (iii) defects arising from abnormal conditions of temperature, dirt or corrosive matter; (iv) any OEM component which is shipped by Powerex with the original manufacturer's warranty, which shall be the sole applicable warranty for such component.

**Limitation of Liability.** NOT WITHSTANDING ANYTHING TO THE CONTRARY HEREIN, TO THE EXTENT ALLOWABLE UNDER APPLICABLE LAW, UNDER NO CIRCUMSTANCES SHALL POWEREX BE LIABLE FOR ANY INCIDENTAL, CONSEQUENTIAL, PUNITIVE, SPECULATIVE OR INDIRECT LOSSES OR DAMAGES WHATSOEVER ARISING OUT OF OR IN ANY WAY RELATED TO ANY OF THE PRODUCTS OR GOODS SOLD OR AGREED TO BE SOLD BY POWEREX TO BUYER. TO THE EXTENT ALLOWABLE UNDER APPLICABLE LAW, POWEREX'S LIABILITY IN ALL EVENTS IS LIMITED TO, AND SHALL NOT EXCEED, THE PURCHASE PRICE PAID.

**Warranty Disclaimer.** Powerex has made a diligent effort to illustrate and describe the Products in its literature, including its Price Book, accurately; however, such illustrations and descriptions are for the sole purpose of identification, and do not express or imply a warranty that the Products are merchantable, or fit for a particular purpose, or that the Products will necessarily conform to the illustrations or descriptions.

**Product Suitability.** Many jurisdictions have codes and regulations governing sales, construction, installation, and/or use of Products for certain purposes, which may vary from those in neighboring areas. While Powerex attempts to assure that its Products comply with such codes, it cannot guarantee compliance, and cannot be responsible for how the product is installed or used. Before purchase and use of a Product, please review the Product applications, and national and local codes and regulations, and be sure that the Product, installation, and use will comply with them.

**Claims.** Any non-warranty claims pertaining to the Products must be filed with Powerex within 6 months of the invoice date, or they will not be honored. Prices, discounts, and terms are subject to change without notice or as stipulated in specific Product quotations. Powerex shall not be liable for any delay or failure arising out of acts of the public enemy, fire, flood, or any disaster, labor trouble, riot or disorder, delay in the supply of materials or any other cause, whether similar or dissimilar, beyond the control of Company. All shipments are carefully inspected and counted before leaving the factory. Please inspect carefully any receipt of Products noting any discrepancy or damage on the carrier's freight bill at the time of delivery. Discrepancies or damage which obviously occurred in transit are the carrier's responsibility and related claims should be made promptly directly to the carrier. Returned Products will not be accepted without prior written authorization by Powerex and deductions from invoices for shortage or damage claims will not be allowed. **UNLESS OTHERWISE AGREED TO IN WRITING, THE TERMS AND CONDITIONS CONTAINED IN THIS LIMITED WARRANTY WILL CONTROL IN ANY TRANSACTION WITH POWEREX.** Any different or conflicting terms as may appear on any order form now or later submitted by the buyer will not control. All orders are subject to acceptance by Powerex.