

MVEVD0404xx1

MVAC ENCL VANE SMALL 5 HP DUPLEX 120G TANK

REVISION NOTES		
DESCRIPTION	ECN	PR/NOR
RELEASE TO PRODUCTION	PXEC0481	XXXXXXXX

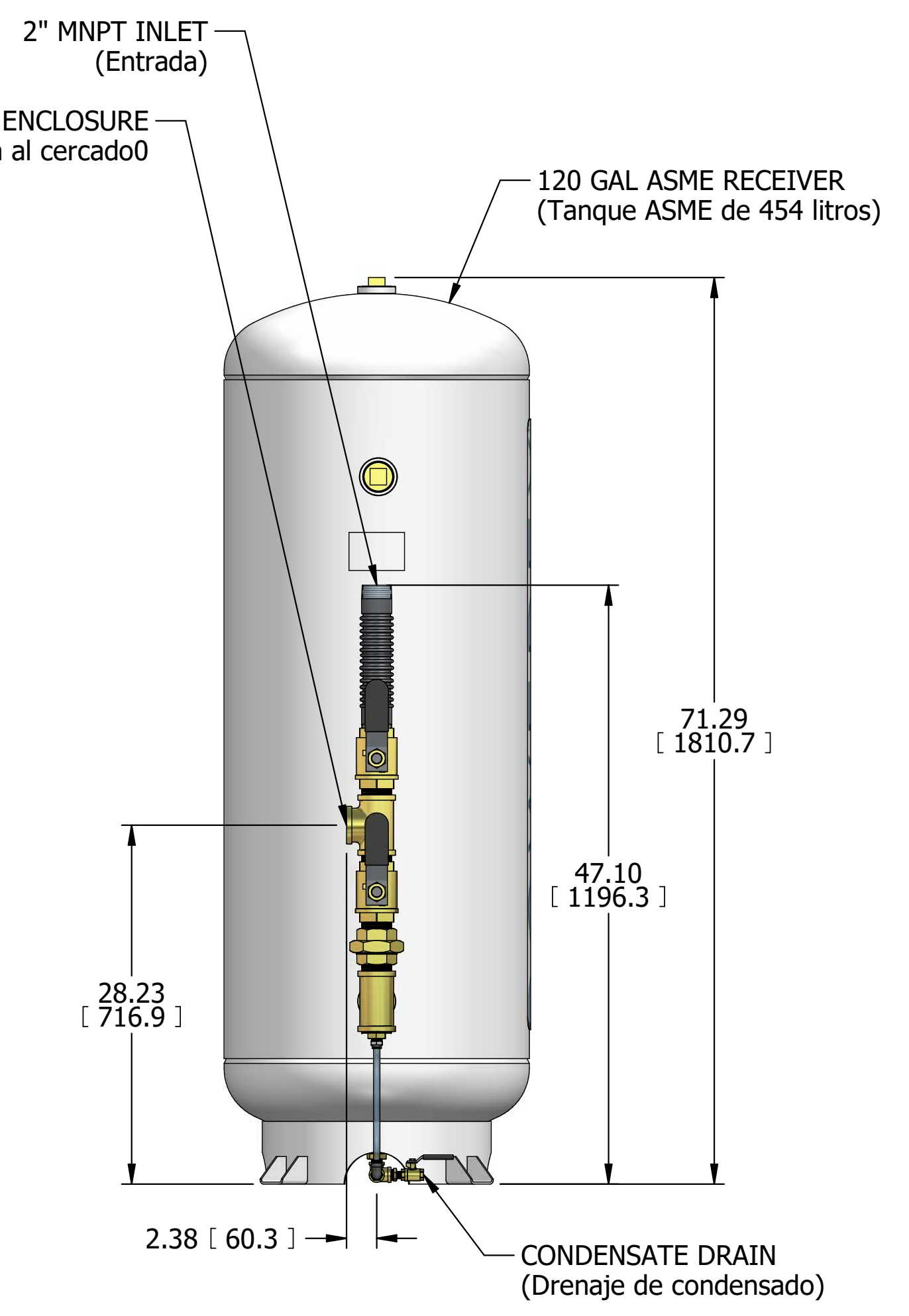
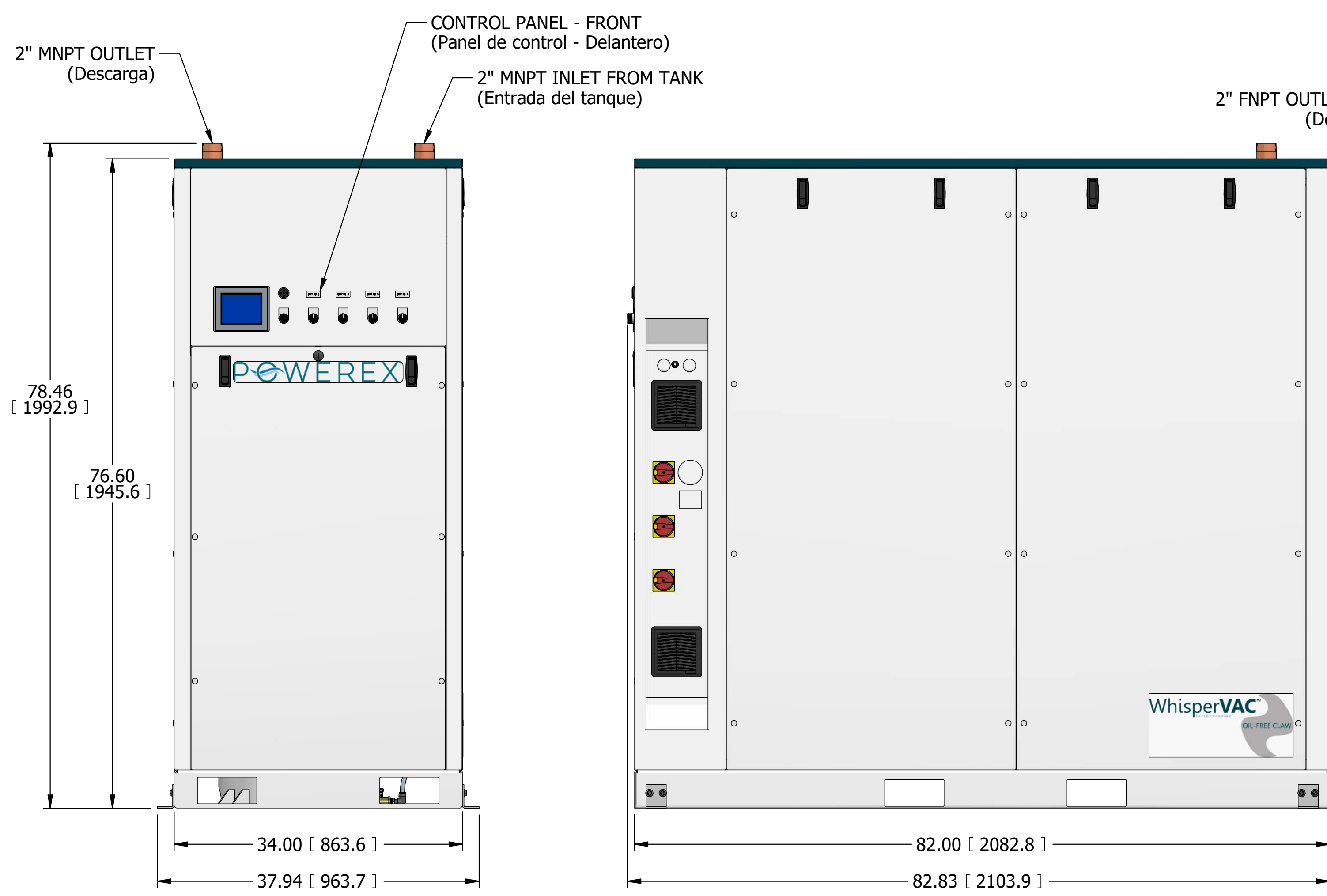
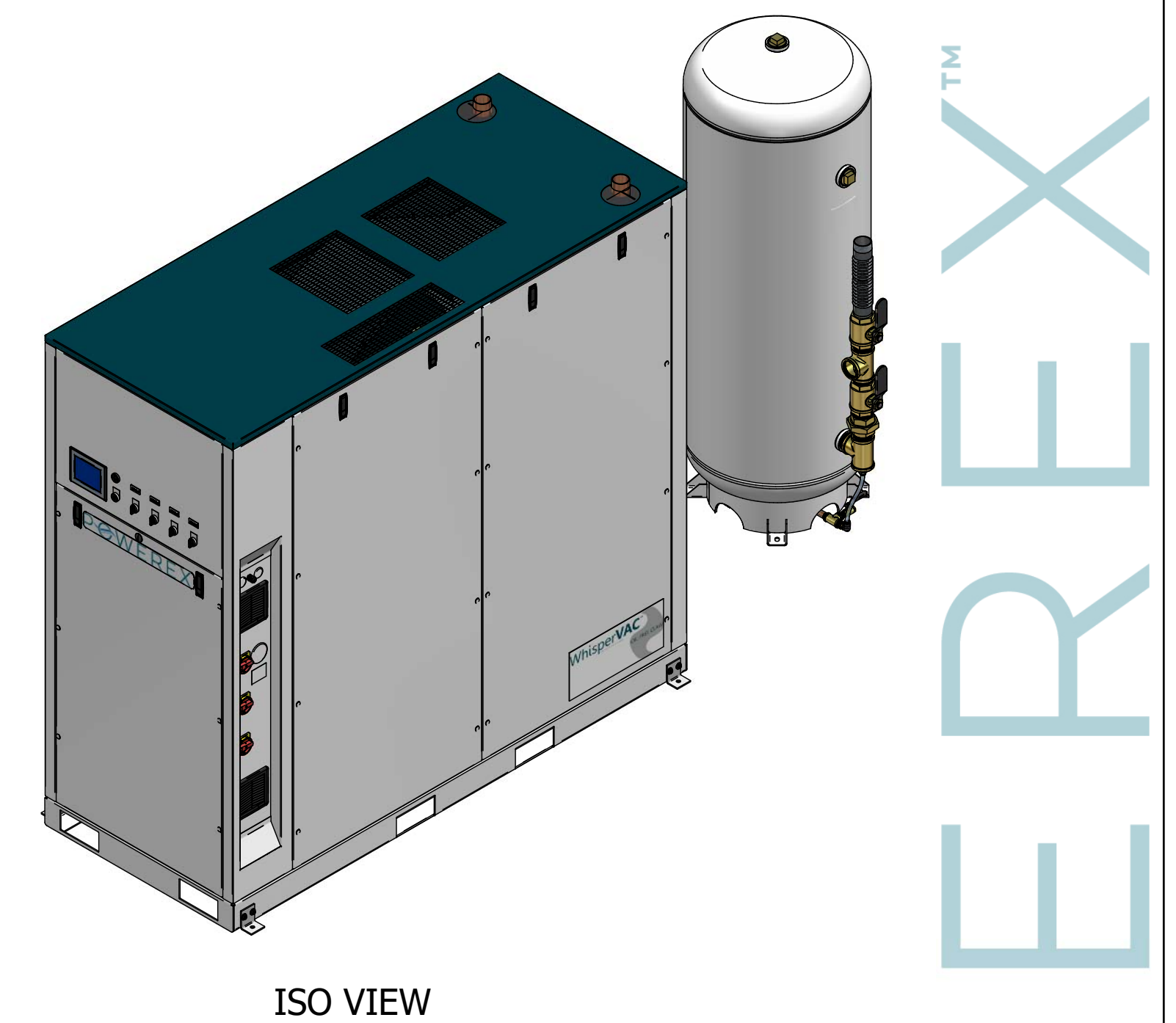
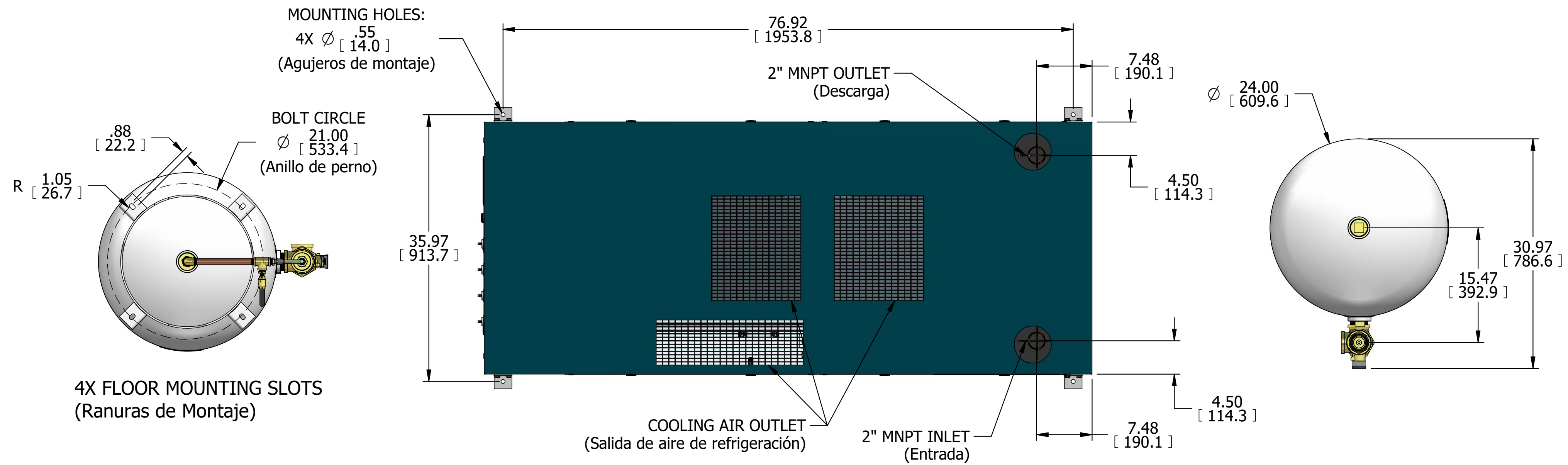

- NOTES:**
- APPROXIMATE WEIGHT: 1851 LBS
 - A MINIMUM OF 24" CLEARANCE IS RECOMMENDED AROUND THE ENTIRE UNIT. CLEARANCE FOR CONTROL PANEL SHALL BE IN ACCORDANCE WITH OSHA/NEC REQUIREMENTS.
 - SYSTEM DESIGNED IN COMPLIANCE WITH U.S. NFPA '99, LATEST EDITION.
1. PESO APROXIMADO: 840kg
2. RECOMENDAMOS QUE EL ESPACIO LIBRE ALREDEDOR DEL SISTEMA DEBE SER COMO MÍNIMO 24" (600 mm). EL ESPACIO LIBRE PARA EL TABLERO DE CONTROL DEBERÁ ESTAR DE ACUERDO CON LOS REQUERIMIENTOS DE SEGURIDAD DE LA OSHA/NEC.
3. EL SISTEMA ESTÁ DISEÑADO DE ACUERDO CON LA ÚLTIMA EDICIÓN DE LA NFPA 99.

SYMBOL LEGEND		DRAWINGS TO CONFORM TO CURRENT REVISION OF THE FOLLOWING STANDARDS:	
TOLERANCES, UNLESS OTHERWISE SPECIFIED:		Y14.3 MULTI AND SECTIONAL VIEW DWGS	
0.XXX ± .005	SOLID EDGE DRAWING	DO NOT SCALE DRAWING FOR DIMENSIONS	
± .001	INCH [mm]	SHEET 1 OF 2	SCALE 1:10
CONFIDENTIAL DISCLOSURE		AUTHOR	REVISION DATE
This drawing is the property of POWEREX of the SCOTT FEZTER COMPANY and is subject to return on demand. Its contents are confidential and must not be copied or submitted to outside parties for use or examination.		rhuy	8/12/2024
ITEM NO: 752338		APPROVALS ON FILE IN PDM	
MATERIAL: ---		POWEREX	
DESCRIPTION: MVAC ENCL VANE SMALL 5 HP DUPLEX 120G TANK		DRAWING NUMBER: MVEVD0404xx1	REVISION: B D

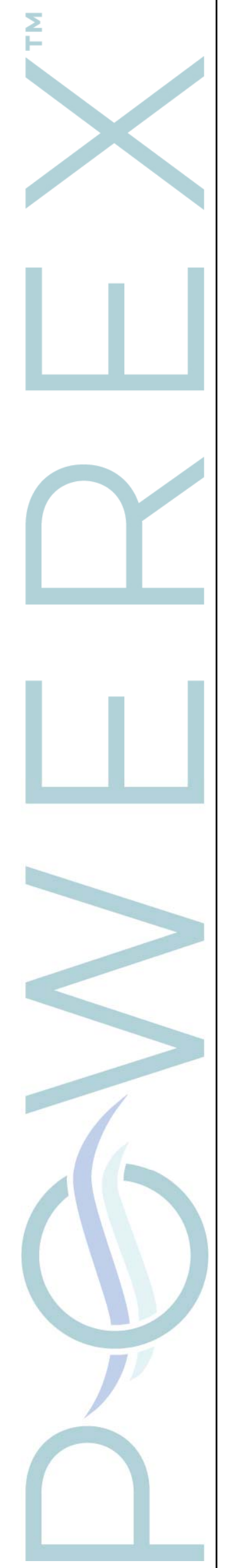

MVEVD0404xx1

MVAC ENCL VANE SMALL 5 HP DUPLEX 120G TANK

REVISION NOTES		
DESCRIPTION	ECN	PR/NOR
RELEASE TO PRODUCTION	PXEC0481	XXXXXXXX

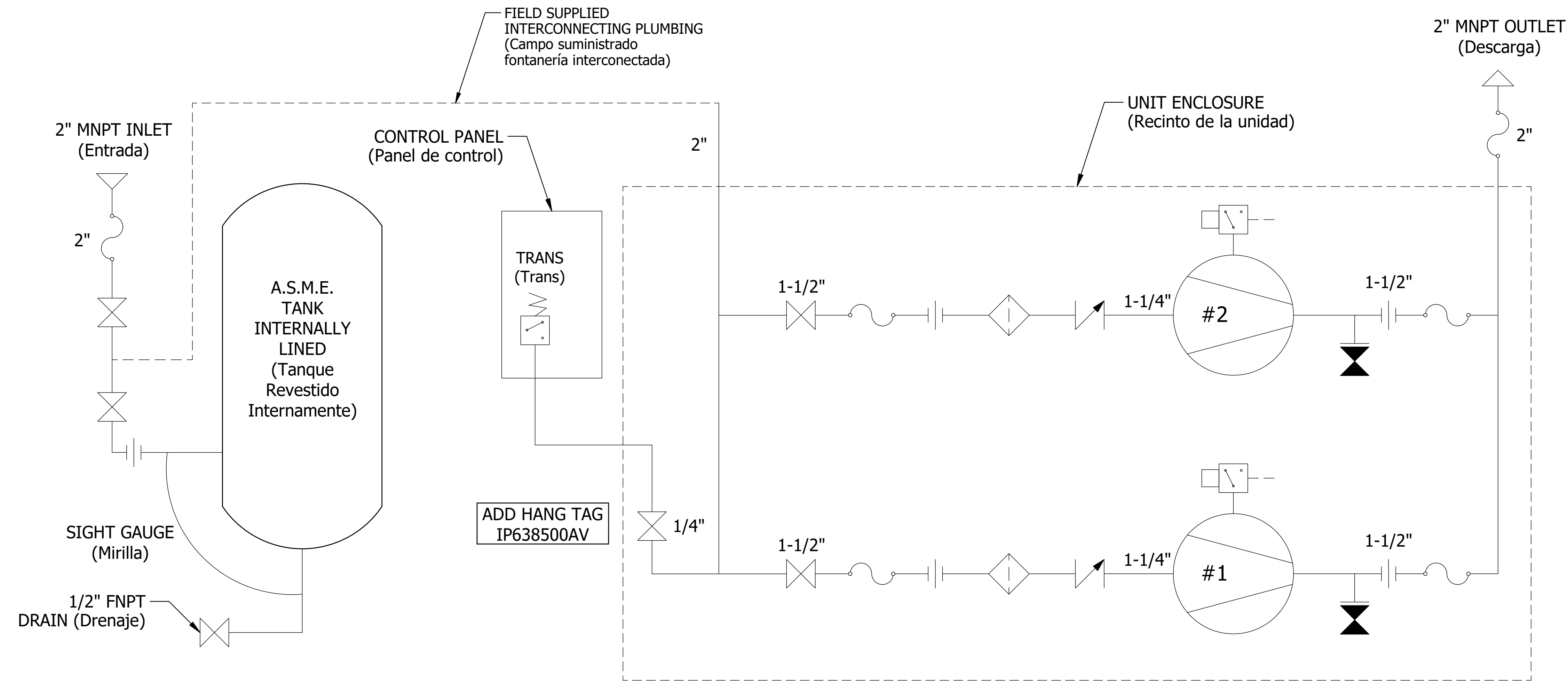

POWEREX™

LEGEND (Leyenda)

	CHECK VALVE (Válvula Cheque)		VACUUM PUMP (Bomba de Succión)
	BALL VALVE (Válvula de Bola)		BUTTERFLY VALVE (Válvula de Mariposa)
	INTAKE FILTER (Filtro admisión)		FLEX HOSE (Manguera flexible)
	GAUGE (Manómetro)		TEMPERTURE SWITCH (Interruptor temperatura)
	UNION (Unión)		VACUUM SWITCH/TRANSDUCER (Interruptor/Transductor vacío)
	DRAIN COCK (Grifo de Drenaje)		SOLENOID VALVE (Válvula solenoide)
	AIR LINE (Tubería de Aire)		CONDENSATE LINE (Línea de Condensado)

SYMBOL LEGEND		DRAWINGS TO CONFORM TO CURRENT REVISION OF THE FOLLOWING AISC STANDARDS:	
		Y14.1 MULTI AND SECTIONAL VIEW DWGS Y14.5 DIMENSIONING AND TOLERANCING	
TOLERANCES, UNLESS OTHERWISE SPECIFIED		DO NOT SCALE DRAWING FOR DIMENSIONS	
0.XX ± 0.05	SOLID EDGE DRAWING		
0.XXX ± 0.005	INCH [mm]	SHEET 2 OF 2	SCALE 1:1
± 1			
CONFIDENTIAL DISCLOSURE		AUTHOR	REVISION DATE
This drawing is the property of POWEREX of the SCOTT FEZTER COMPANY and is subject to return on demand. Its contents are confidential and must not be copied or submitted to outside parties for use or examination.		rhuy	8/12/2024
ITEM NO: 752338		APPROVALS ON FILE IN PLM	
MATERIAL: ---		POWEREX™	
DESCRIPTION: MVAC ENCL VANE SMALL 5 HP DUPLEX 120G TANK		150 PRODUCTION DRIVE, HARRISON OH 45030 (888) 769-7979	
DRAWING NUMBER: MVEVD0404xx1		REVISION: B	SIZE: D