

Specification

General

The Powerex enclosed laboratory vacuum system is designed to create a suction to remove unwanted fluids or gases from hospital/ laboratory working areas. Each system is completely tested before shipment and includes:

- Multiple vacuum pumps and associated equipment
- Sound reducing enclosure
- ASME air receiver (optional)
- Laboratory control panel
- Exhaust silencer(s)

Each pump is factory piped to a common intake manifold and exhaust manifold. Intake isolation valves are included. Each pump-motor assembly is isolation-mounted to the internal frame structure.

Claw Vacuum Pump

Each pump shall be a rotary claw type vacuum pump, and shall be direct-driven through a shaft coupling by a C-face, TEFC electric motor.

- Each vacuum pump shall be dry-running, featuring two claw-type, non-contacting rotors and shall not require any sealing fluid in the pumping chamber, assuring virtually maintenance-free operation.
- Each vacuum pump shall include an internal relief valve, and a built-in, anti-suck-back valve mounted at the pump inlet.
- Each pump within the system shall include a check valve, inlet and discharge flex connectors, a 5 micron inlet filter and a pump isolation valve on the intake connection.

Motor

The motor is continuous duty, C-face, TEFC, suitable for 208-230, or 460V, 3 phase, 60 hertz electrical operation.

Sound Reducing Enclosure

The system is constructed with an internal frame and steel base system with an individual vibration isolation mounted vacuum pump- motor module. The electrical controls are located at the front of the unit and are accessed separately from the rest of the enclosure. Enclosure side and back panels are easily removed to perform routine maintenance and inspection. Enclosure shall reduce noise to a level not to exceed 80 dB(A).

Heat Management

The pumps shall be arranged in a vertical stack configuration so that each pump has its own individual bay that's isolated with sheet metal dividers. Heated air from the pump and motor will exhaust into the pump bay. Cooling air will enter each pump bay from the front/bottom of the system. An electric cooling fan shall be placed in each pump bay near the pump motor in an orientation that is perpendicular to the pump motor. Heated air will be forced out of each pump bay by the electric cooling fan through an integral duct that connects each pump bay. The integral duct shall include baffling to further reduce the amount of noise that can escape. The heated air leaves the system through the top. The cooling system shall be properly sized and placed so that the vacuum pump motor is kept sufficiently cool under all expected operating conditions.

Premium Control Panel

The control system provides automatic lead/lag sequencing and automatic alternation of all pumps in order to equalize the amount of usage among the available vacuum pumps. The Premium Control panel shall include a gateway server card and all features listed below:

- PLC controller and a color touch screen panel which displays the operating status of the unit
- Building automation communication gateway with BacNet® protocol and Web server features. Web server features include email notifications in case the system is in alarm or has achieved one its maintenance intervals and requires service.
- The UL listed control panel shall be integrated with the compressor cabinet from the factory. The controls will operate and continuously monitor the system and provide information and alarms to the user through the HMI display. Additional user control is enabled with externally mounted HOA switches for each pump.
- Magnetic contactors with Motor protector circuit breaks featuring through-the-door operators with lockable control knobs. Motor protector circuit breakers feature high inrush capability.
- Vacuum transducer for process control
- Single point power connection
- Redundant 120V AC control transformers with fused primary and secondary protection.

- System overload trip, high temperature conditions or maintenance intervals for the pump will result in visual and audible alarms

Vacuum Receiver

The internally lined ASME rated vacuum receiver shall be equipped with a sight gauge, isolation valves, and a manual drain.

Optional VFD Control Panel

Variable Frequency Drive (VFD) control improves efficiency over a conventional “on/off” demand based system by more closely matching the pump speed to the changing load requirements. All VFD systems come standard with a Premium Control panel. The VFD and Premium Control Panel shall include a gateway server card and all features listed below:

- PLC controller and a color touch screen panel which displays the operating status of the unit
- Building automation communication gateway with BacNet® protocol and Web server features. Web server features include email notifications in case the system is in alarm or has achieved one its maintenance intervals and requires service.
- Ethernet port for connection to BacNet® server or direct connection to facility Ethernet for viewing of system operations and status via device IP-address.
- The UL listed control panel shall be integrated with the compressor cabinet from the factory. The controls will operate and continuously monitor the system and provide information and alarms to the user through the HMI display. Additional user control is enabled with externally mounted HOA switches for each pump and VFD start/stop switch.
- Magnetic contactors with motor protector circuit breakers featuring panel-mounted operators with lockable control knobs. Motor protector circuit breakers feature high inrush capability.
- Vacuum transducer for process control
- Single point power connection
- Redundant 120V AC control transformers with fused primary and secondary protection
- System overload trip, high temperature conditions or maintenance intervals for the pump will result in visual and audible alarms.

Multiple Enclosures (Triplex through Hexaplex)

- Each Enclosure requires its own 3 phase electrical connection.
- The controls of multiple enclosures shall be based on Primary – Subordinate logic. The Primary enclosure shall include the HMI and the Primary PLC. The Primary PLC contains all logic to run the entire system.
- The Subordinate PLC contains the minimal amount of logic to respond to Primary PLC commands and operate independently in fail-safe mode.
- The only connection between Enclosures shall be an Ethernet cable.
- If inter-Enclosure connection is broken, each Enclosure shall operate independently. The Primary Enclosure will run the same as if it were connected and the Subordinate Enclosure will operate using a backup vacuum switch. Each PLC will attempt to reconnect multiple times per second. Once connection is re-established, the entire system shall operate normally.
- All Enclosed Vacuum systems shall be easily expandable to up to 6 pumps.
- VFD (if equipped) - a VFD controller shall be included with each Enclosure.

Available Options

- Variable Frequency Drive (VFD) Control Panel

Dimensions									
Model	Dim. A1	Dim. A2	Dim. A3	Dim. B	Dim. C	Dim. D	Dim. E	Inlet	Outlet
Pentaplex									
LVECP0505	34.3"	93"	N/A	82.8"	143"	78.5"	78.2"	3"	3"
LVECP0755	34.3"	93"	N/A	82.8"	143"	78.5"	78.2"	3"	3"
LVECP1505	34.3"	93"	151"	82.8"	143"	78.5"	78.2"	3"	3"
Hexaplex									
LVECH0505	34.3"	93"	N/A	82.8"	143"	78.5"	78.2"	3"	3"
LVECH0755	34.3"	93"	N/A	82.8"	143"	78.5"	78.2"	3"	3"
LVECH1505	34.3"	93"	151"	82.8"	143"	78.5"	78.2"	3"	3"

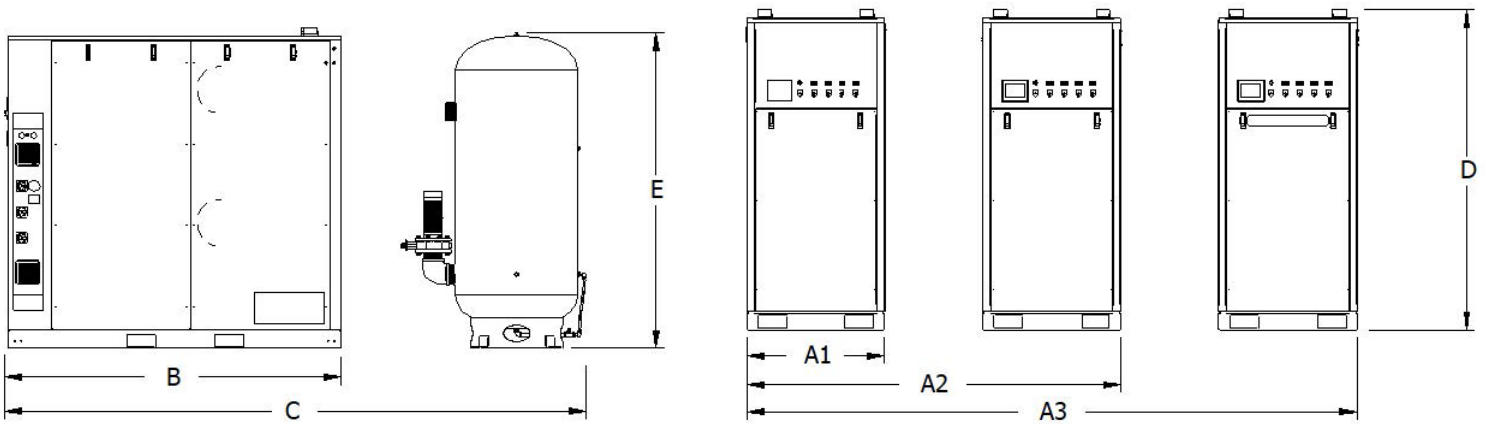
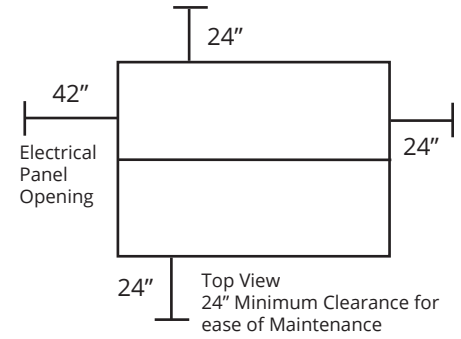

Laboratory Claw Enclosed Vacuum Systems*									
Model	Pump HP	SCFM @ 19" Hg	Tank Size (gal)	BTU/Hr	dB(A) Level	System F.L.A.			System Weight (lbs)
						208V	230V	460V	
Pentaplex[†]									
LVECP0505	5 (5)	190	200 V	54,190	74	69.2	63.9	34.1	5,178
LVECP0755	7.5 (5)	325	200 V	81,280	74	117.2	95.9	50.1	6,113
LVECP1505	15 (5)	645	200 V	162,565	78	204.4	177.0	89.5	7,938
Hexaplex									
LVECH0505	5 (6)	228	200 V	65,028	75	82.3	76.0	40.5	5,718
LVECH0755	7.5 (6)	390	200 V	97,536	75	139.9	114.4	59.7	6,838
LVECH1505	15 (6)	774	200 V	195,078	79	248.5	215.3	109.5	8,738

Notes:
 * Table specifications are defined at sea level conditions with all pumps in operation. Consult factory for installations above 3,000 ft. elevation.
[†] Listed pentaplex systems consist of primary (2-pump) and secondary (1-pump) cabinets.