

Product Line Overview

The zone valve box shall be the Powerex ZVB series and must be installed and tested in strict accordance with NFPA 99 standards and or any other local codes before use.

The valves shall be three-piece, ball-type design with a forged brass body and a chrome plated, brass ball for sizes 0.5" to 2". Ball seats, stem seals, and stem washer shall be reinforced Teflon (PTFE), with Viton stem and flange o-rings. A blow-out proof stem shall be used and the valve shall have a maximum pressure rating of 600 psi (29in/Hg vacuum).

All valves shall be provided with type K copper tubing extensions to facilitate installation. Each valve assembly shall be supplied cleaned for oxygen service in accordance with current CGA standards. The valve tube ends shall be capped to prevent contamination prior to installation.

Each valve assembly shall incorporate three 1/8" NPT ports. One patient-side port offers a location for attaching a pressure or vacuum gauge. The second patient-side port allows for the connection of a gas sensor, such as a DISS-fitted transducer. The third port, situated upstream of the valve, can be employed for purging while brazing during installation.

Each valve shall be provided with an identification bracket for the purpose of applying an approved medical gas identification label. A package of labels shall be supplied with each zone valve box for application by the installer.

Gauges shall be 1.5" diameter for monitoring pressure and vacuum.

Optional DISS gas specific sensor port is available for each valve.

The valve box shall be 14 gauge sheet steel construction painted to prevent rust. A single box shall house from one to seven valves. Box shall be supplied with an adjustable plaster flange .425" to 1.35" for easy mounting.

Valve box assembly shall be supplied with a white extruded high-impact ABS frame which encloses an easily removable flexible window. The window shall be an opaque, white, flexible cover with clear sections for gauge and gas label viewing. A pull-out ring, pre-attached to the center of the window, facilitates its removal. The window shall not be replaceable while any valve is in a closed position. Window shall include the following statement: "MEDICAL GAS SHUTOFF VALVES. CAUTION: CLOSE ONLY IN EMERGENCY."

Features and Benefits

- Designed and manufactured in the USA
- 5 year warranty on parts, 2 year warranty on labor
- Meets NFPA 99 requirements
- All valves have one source-side and two patient-side 1/8" NPT ports
- Valves shall be piped left to right
- All valves are three-piece in-line repairable full port ball valves
- Blow-out proof stem design
- Accommodates up to 7 valves sizes from 0.5" to 2"
- Valves to have a working pressure of 600 psi (29 in/Hg vacuum)
- All valves cleaned for Oxygen service
- Full color coded labeling (one of each medical gas provided)
- 1.5" diameter gauges sold separately

Ordering Information

ZVBNXXXXXXXX

N = NUMBER OF VALVES

1 through 7

X's = VALVE SIZES

A = 0.5"

E = 1.5"

B = 0.75"

F = 2"

C = 1"

X = Blank

D = 1.25"

Ex. ZVB3ABF = Zone Valve
Box with 3 valves: 0.5",
0.75", and 2".

Disclaimers

A 2" valve cannot be in the upper most position of a multi valve box.

A 2" valve cannot be immediately above or below a 2" valve.

A 1-1/2" valve cannot be immediately below a 2" valve.

Zone Valve Box Specification

0.5" - 2" Valves



Dimensions

Valve Count	Width (in)	Depth (in)	Height (in)	Top Valve Height from Bottom (in)
1	13.12	4.16	11.25	2.5
2	13.12	4.16	11.25	7.5
3	13.12	4.16	16.00	12.36
4	13.12	4.16	20.88	17.26
5	13.12	4.16	25.75	22.13
6	13.12	4.16	30.62	27.01
7	13.12	4.16	35.50	31.88

Copper Tube Extension Length: 4.10 ± .10 IN

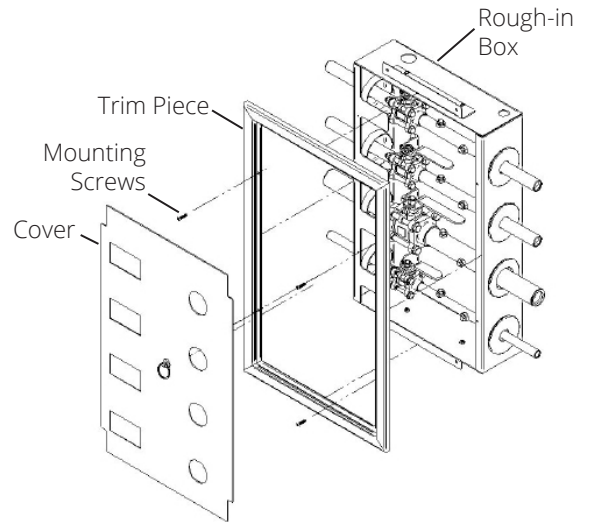

Box Configurations

Reference chart above for dimensions

FRONT VIEW

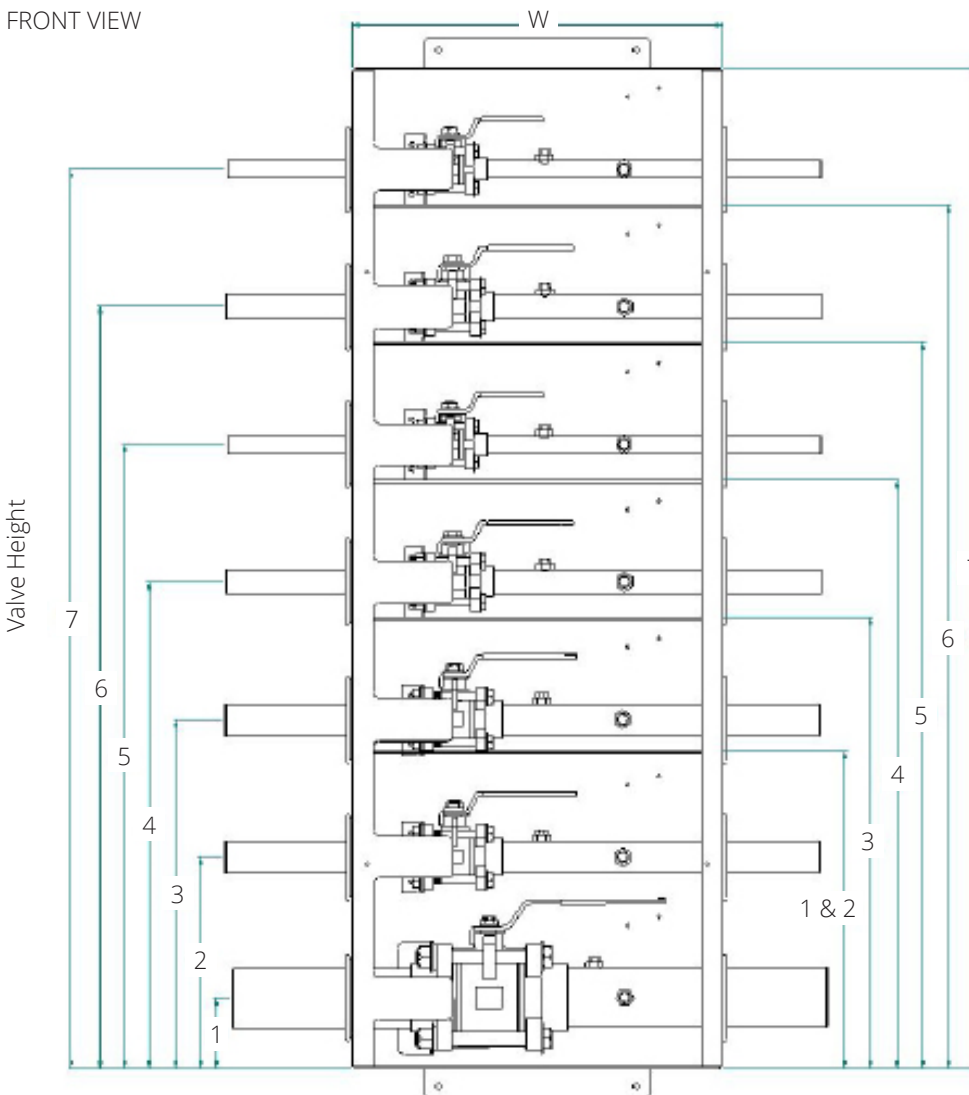

SIDE VIEW

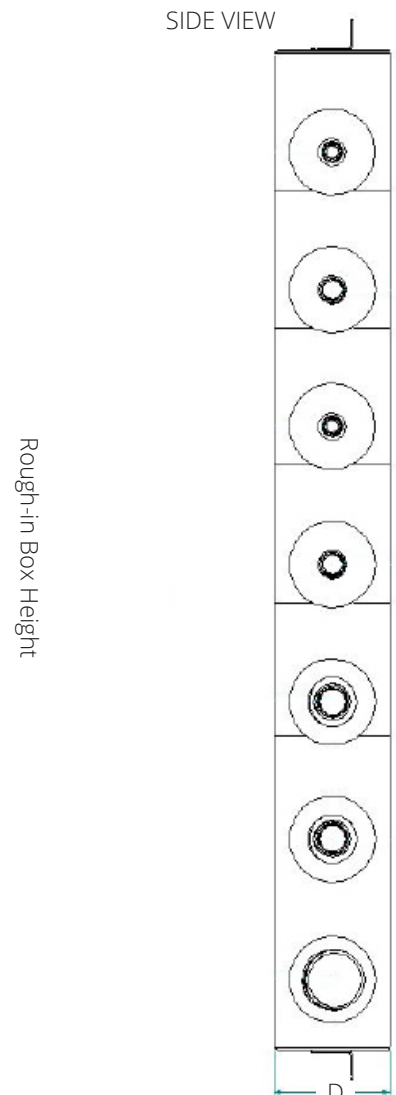

Additional Accessories (sold separately)

Gauges

NOTE: One gauge must be selected for each valve

Part Number	Description	
GA730100AV	0-100 PSI Pressure Gauge	O2, Med Air, N2O, CO2
GA730200AV	0-300 PSI Pressure Gauge	N2, Instrument Air
GA730300AV	0-30 inHG Vacuum Gauge	Med Vac, WAGD

Sensing Kits

NOTE: Sensing Kits are optional and may be added to any valves

Part Number	Description
SENSE-ALL	Sensing Kit - All Gases
SENSE-2V	Sensing Kit Adapter for 2" Valve