

Industrial Vacuum Tankmount System

Please read and save these instructions. Read carefully before attempting to assemble, install, operate or maintain the product described. Protect yourself and others by observing all safety information. Failure to comply with instructions could result in personal injury and/or property damage! Retain instructions for future reference.

Description

GENERAL

Powerex vacuum tankmount simplex/ duplex units are designed to provide vacuum for process, molding, packaging, printing and other similar facilities.

Vacuum tankmount systems can be used for a variety of applications. A vacuum pump creates a suction to rid unwanted fluids or gases from the working area. Waste fluids are deposited into a customer-provided collection tank and the vapors are filtered through the system, then vented to the atmosphere.

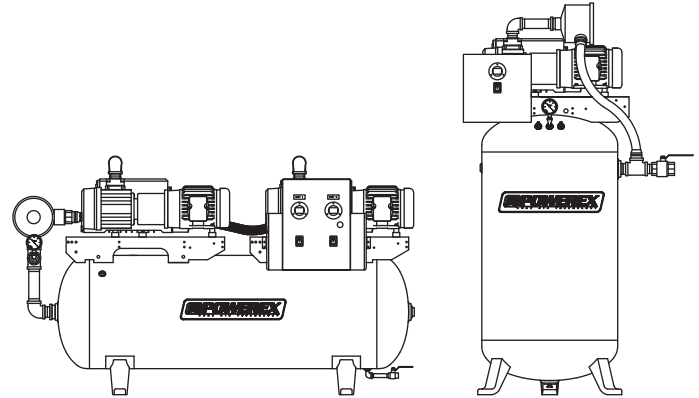

Safety Guidelines

This manual contains information that is very important to know and understand. This information is provided for SAFETY and to PREVENT EQUIPMENT PROBLEMS. To help recognize this information, observe the following symbols.

⚠ DANGER

Danger indicates an imminently hazardous situation which, if not avoided, WILL result in death or serious injury.

⚠ WARNING

Warning indicates a potentially hazardous situation which, if not avoided, COULD result in death or serious injury.

⚠ CAUTION

Caution indicates a potentially hazardous situation which, if not avoided, MAY result in minor or moderate injury.

NOTICE

Notice indicates important information, that if not followed, may cause damage to equipment.

A SEPARATE SAFETY BOOKLET IS PROVIDED ALONG WITH THIS MANUAL. READ AND UNDERSTAND THE SAFETY BOOKLET.

Unpacking

Immediately upon receipt of the vacuum system, inspect for any damage which may have occurred during shipment. Repair or replace damaged items before use. The specification decal should be checked to verify the correct model and voltage.

⚠ WARNING

Do not operate unit if damaged during shipping, handling or use. Damage may result in unsafe conditions and cause injury or property damage.

Specifications

Product	IVD / IVS Series	
Operating Voltages	208V, 230V, 460V	
Control Panel	UL508A and NFPA compliant	
Motor	TEFC Electric Motor	
Tank	ASME Rated for 200 psi MAWP/ Full Vacuum	
Pump	Capable of operating at: 29.3 inch Hg (sea level) continuous duty for 1 HP - 1-1/2 HP 29.3 inch Hg (sea level) continuous duty for 2 HP - 5 HP 29.3 inch Hg (sea level) continuous duty for 7.5 HP 29.3 inch Hg (sea level) continuous duty for 10 HP	
Drive	Direct	
Tank Sizes	See Page 2	
Performance	See Page 2	
Inlet Vacuum Connections	IVS 1 HP - 1 inch 1.5 HP to 5 HP - 1-1/2 inch 7.5 HP to 10 hp - 2 inch	IVD -- 1 HP to 5 HP - 1-1/2 inch 7.5 HP, 10 HP - 2 inch

Industrial Vacuum Tankmount System

Engineering Specifications

Industrial Tankmount Simplex and Duplex

	Model	HP	Nominal CFM	SCFM @ 19" Hg	SCFM @ 25" Hg	RPM	Voltage	Tank Size (Gallons)	Dimensions L x W x H	Ship Weight (lbs.)
Simplex	IVS015	1.5	18	7.0	3.0	1740	208/230/460	30 V 60 V	30 x 23 x 68 39 x 23 x 70	295 375
	IVS020	2.0	26	11.0	5.0	1740	208/230/460	60 V	37 x 30 x 71	435
	IVS030	3.0	36	17.0	8.0	1750	208/230/460	80 V	37 x 32 x 71	510
	IVS040	5.0	70	26.0	12.0	1750	208/230/460	80 H	76 x 24 x 47	590
	IVS050	5.0	106	37.9	17.0	1740	208/230/460	80 H	78 x 31 x 49	620
	IVS075	7.5	130	52.0	23.0	1760	208/230/460	120 H	85 x 28 x 56	930
	IVS100	10	196	77.0	35.0	1760	208/230/460	200 H	80 x 33 x 64	1340
Duplex	IVD015	1.5 (2)	36	14.0	6.0	1740	208/230/460	80 H	71 x 30 x 43	620
	IVD020	2.0 (2)	52	22.0	10.0	1740	208/230/460	80 H	71 x 29 x 43	740
	IVD030	3.0 (2)	72	34.0	16.0	1750	208/230/460	120 H	78 x 30 x 47	910
	IVD040	5.0 (2)	140	52.0	24.0	1750	208/230/460	120 H	78 x 31 x 53	980
	IVD050	5.0 (2)	212	75.8	34.0	1740	208/230/460	120 H 200 H	79 x 33 x 55 87 x 33 x 60	1040 1320
	IVD075	7.5 (2)	260	104.0	46.0	1760	208/230/460	200 H	95 x 37 x 61	1760
	IVD100	10 (2)	392	154.0	70.0	1760	208/230/460	240 H	94 x 50 x 60	2070

* End vacuum is 29.3" Hg, ACFM is measured at actual inlet conditions, SCFM is measured at standard conditions (68° F, 29.92" Hg or 14.7 psia)

* Control panel will include a magnetic starter with overload protection, an hour meter, an on/off switch or a selector switch, and a minimum run timer (5HP and above) for each pump. Duplex starter will include an alternator.

NOTE: For system electrical information, see the wiring diagram shipped with the unit.

Components

VACUUM TANKMOUNT SYSTEMS

The IVS and IVD (Vacuum Tankmount Simplex and Duplex) systems consist of one or two rotary vane vacuum pumps that can be operated independently or as a system. The duplex systems control panel sequences the vane pumps to maintain a continuous vacuum on the system while equally managing the on time of each pump. The direct drive vacuum pump is equipped with a continuous duty TEFC tri-voltage motor. Maintenance on the rotary vane pump is simplified through convenient access to both ends of the pumps.

The LVP series pump draws air through a 10 micron polyester filter and external check valve. An additional built-in check valve is provided for added protection against leakage. A stainless steel protective screen is built into the inlet flange as standard equipment on the LVP series pumps. The inlet screen protects the pump from large particles entering the rotor/vane area.

RECEIVER TANK

The ASME National Board registered air receiver is available in 30 to 240 gallon sizes. Receivers are provided with a manual drain.

CAUTION

Factory installed receiver is used for vacuum capacity only

and is NOT a collection receiver.

⚠ DANGER

Never drill holes in, or perform any

welding on tanks or use them beyond the rated pressure settings.



CONTROL PANEL

The NEMA 1, UL listed control panel is provided in simplex or duplex configurations. Both utilize a 120V AC control transformer with fused primary and secondary circuit. An adjustable vacuum switch signals the pump(s) on cycle.

All Powerex vacuum systems employ minimum run timers via a PLC or time delay relay for each pump. Minimum run timers will assure that no more than six starts per hour can occur on each pump. A duplex unit employs timed alternation via the PLC to maintain even run hours on each pump. The control panel is provided with a HOA (hand-off-auto) switch and hour meter for each pump.

ELECTRIC MOTORS

- The electric motors are NEMA rated by horsepower.
- TEFC construction is standard.
- Class F rated insulation.
- Ambient temperatures to 40°C (104°F).
- Service factor of 1.15 or higher.
- Continuous duty rated.

Installation

⚠ WARNING

Disconnect, tag and lockout power before attempting to install, service, relocate or perform any maintenance.



⚠ CAUTION

Do not lift or move unit without appropriately rated equipment. Be sure the unit is securely attached to lifting device used. Do not lift unit by holding onto tubes or coolers. Do not use pumps to lift other attached equipment.

INSTALLATION SITE

1. The vacuum system must be located in a clean, well lit and well-ventilated area.
2. The area should be free of excessive dust, toxic or flammable gases and moisture.
3. Never install the vacuum system where the surrounding temperature is higher than 104°F (40°C) or where humidity is high.
4. Clearance must allow for safe, effective inspection and maintenance.

MINIMUM CLEARANCES

Above	36 inches
Other sides	36 inches

5. If necessary, use metal shims or leveling pads to level the system. Never use wood to shim the unit.
6. The unit has mounting holes to allow bolting to the floor. Secure it as necessary. Rubber composite isolation pads should be used to minimize transmission of noise and vibration to the building. Additional measures for isolation may be required. Drill a hole through the isolation pad and center it under the mounting point.

VENTILATION

1. If the vacuum system is located in a totally enclosed room, an exhaust fan with access to outside air make up air must be installed.
2. Never restrict the cooling fan exhaust air. Maintain a minimum of 2 feet of clearance around entire unit.
3. Never locate the vacuum system where hot exhaust air from other heat generating units may be pulled into the unit. Keep pump vents at least 12 inches away from any wall or obstruction.

LUBRICATION

NOTE: See pump manual (shipped with this unit) for pump lubrication information.

Vacuum System Diagram

SIMPLEX

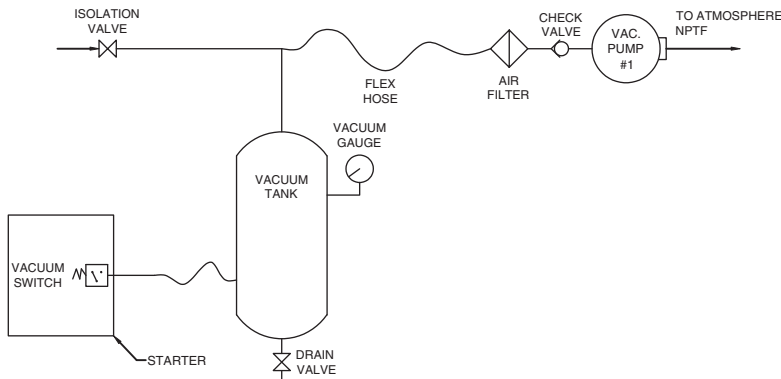

NOTES:

- 1) Other arrangements that differ from this schematic in such items as the number of pumps, receivers, piping layout, etc., or other arrangements that meet specific recommendations of the vacuum source equipment manufacturer are permissible.
- 2) A drip leg must be installed at each pump outlet if exhaust is piped away from vacuum system.

DUPLEX

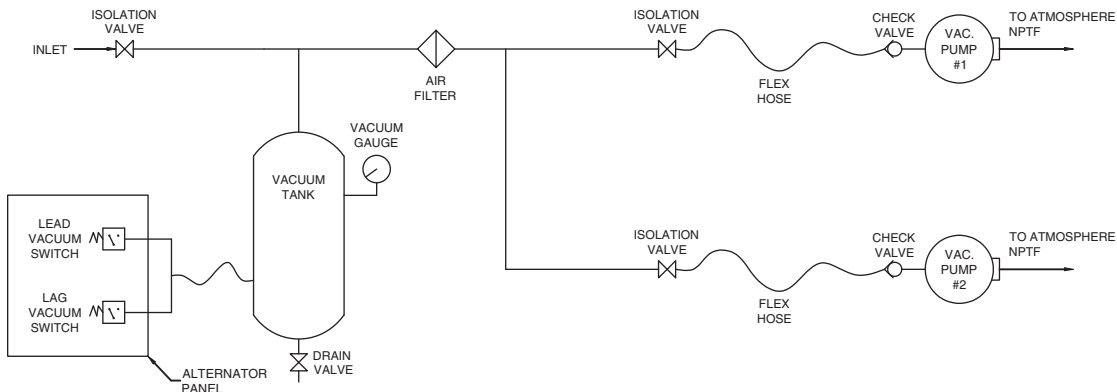

Industrial Vacuum Tankmount System

Installation (Continued)

WIRING

⚠ DANGER Lock out and tag out the electrical supply before servicing the equipment.



⚠ DANGER Electrical shock hazard. Make sure the system is grounded in accordance with NEC and local requirements.



All electrical hook-ups must be performed by a qualified electrician. Installations must be in accordance with local and national electrical codes. Make sure power supply conductors are sized adequately for full system demand.

PIPING

The system may have temporary shipping supports in place. These should be removed when the system piping is connected to the building piping. Appropriate supports should be added to the system when building tie in is completed.

The system has a single point inlet. An optional flexible connector is available. An optional flexible connector for tying in to the system exhaust is also available.

1. Make sure the piping is lined up without being strained or twisted when assembling the piping for the unit.
2. Appropriate expansion loops or bends should be installed at the unit to avoid stresses caused by changes in hot and cold conditions.
3. Piping supports should be anchored separately from the unit to reduce noise and vibration.
4. Never use any piping smaller than the unit inlet and outlet connection.
5. Use flexible hose to connect the inlet and outlet of the unit to the piping so that the vibration of the unit does not transfer to the piping.
6. A drip leg and a drain valve must be installed near the exhaust fitting of each vacuum pump. The drip leg must prevent collected condensation from draining back into the pump or pumps.
(The optional Powerex exhaust connector includes the drip leg and valve.)
7. The exhaust piping should be kept short and have the least restriction possible. The flex connector supplied by Powerex may be repositioned (changed from vertical to horizontal and the elbow turned or removed) if desired to achieve a more effective installation to match the field installed exhaust piping. Repositioning is desirable if the final system plumbing design can be shorter by doing so.

8. Never use any piping smaller than the pump connection. To determine the minimum required pipe size for a vacuum system exhaust, calculate the equivalent straight length of the run. Never use a pipe size smaller than the flex connector supplied by Powerex or smaller than the size shown in the 100 foot column on the chart for the CFM of the pump. The equivalent straight length is the length of all the pipe needed from the flex connector to the final outlet plus a factor for each elbow, cross or tee. Pipe must be smooth ID. If rough pipe is used, increase by one size.
9. If a grating or grille is used at the end of the exhaust pipe, make sure its open area is at least equal to the area of the exhaust pipe.

Pipe Size Requirements			
System CFM	Minimum Pipe Size for 100 feet	Minimum Pipe Size for 300 feet	Minimum Pipe Size for 600 feet
5	1.0	1.25	1.5
7	1.0	1.25	1.5
11	1.25	1.5	1.5
21	1.25	1.5	1.5
26	1.25	1.5	2.0
32	1.25	1.5	2.0
38	1.5	2.0	2.5
52	1.5	2.0	2.5
58	1.5	2.5	2.5
63	2.0	2.5	2.5
65	2.0	2.5	3.0
87	2.0	2.5	3.0
104	2.0	3.0	3.5
111	2.5	3.0	3.5
154	2.5	3.0	3.5
156	2.5	3.5	4.0
168	2.5	3.5	4.0
195	3.0	3.5	4.0
258	3.0	3.5	4.0
260	3.5	4	5.0
387	3.5	4	5.0
516	4	5	6.0

If the system extends beyond 600 equivalent straight feet, use one size larger pipe.

Installation (Continued)

Approximate system CFM equals the number of pumps running times CFM in table below. (Data below is for reference only, if actual pump CFM is higher than shown, use the higher value.)		
HP	Vane Pump CFM @ 19"	Claw Pump CFM @ 19"
1.0	2.0	
1.5	7	
2.0	11	16
3.0	17	21
4.0		29
5.0	26	
5.0	38	
5.4		38
6.4		52
7.5	52	65
8.7		77
10.0	65	84
10.0	77	
15.0	111	129
20.0	137	
25.0	168	

Pipe Size	Equivalent length for 90° elbow, cross, or tee	Equivalent length for 45° elbow
	3.0 feet	1.5 feet
1.5	3.75 feet	1.8 feet
2.0	5.0 feet	2.5 feet
2.5	6.25 feet	3.1 feet
3.0	7.5 feet	3.8 feet
3.5	8.78 feet	4.4 feet
4.0	10.0 feet	5.0 feet
5.0	12.5 feet	6.25 feet

Operation

BEFORE START UP

1. Make sure all safety warnings, labels and instructions have been read and understood before continuing.
2. Remove any shipping materials, brackets, etc.
3. Confirm electric power source and ground have been firmly connected.
4. Be sure all vacuum connections are tight.
5. Ensure all fuses, circuit breakers, etc., are properly sized.
6. Make sure inlet filter is properly installed.
7. Close drain valve.

▲WARNING *Risk of injury. Make sure no one is in contact with any moving parts during the rotation check.*



START-UP AND OPERATION

1. Follow all procedures under "Before Start-Up" before attempting operation of the vacuum pump.
2. Switch on electric source breaker.
3. Visually check rotation of vacuum pump. If rotation is incorrect, have a qualified electrician correct motor wiring.

NOTICE

Switch breaker OFF if vacuum pump will not be used for a

long period of time.

4. Open tank intake valve completely.
5. Check for excessive vibration, unusual noises or leaks during operation.
6. Close intake valve completely.
7. Check the vacuum (inch/Hg.). Ensure designated vacuum setting is reached by checking vacuum gauge.

Industrial Vacuum Tankmount System

Maintenance Schedule

Item	Action needed	Operating Hours								Remarks
		500	600	2500	5000	10,000	15,000	20,000		
Inlet air filter	Inspect/Replace	●		▲						Every 2500 hours or less
Blower fan	Clean				●	●	●	●		
Fan shield	Clean				●	●	●	●		
Pump fins	Clean				●	●	●	●		
Bearings	Replace							▲		
Vanes	Replace							▲		25,000 hours continuous
Shaft seal	Replace							▲		
Coalescing filter	Replace			▲						
Inlet check valve	Replace					▲		▲		
Vacuum switch	Inspect				●	●	●	●		
Oil filter	Replace		▲							
Oil	Replace		▲							

- Inspect
- ▲ Replace

NOTES:

1. Inspect and perform maintenance periodically according to maintenance schedule.
2. The maintenance schedule relates to the normal operating conditions. If the circumstances and load condition are adverse, shorten the interval time and perform maintenance accordingly.

Average Evacuation Time (in seconds)

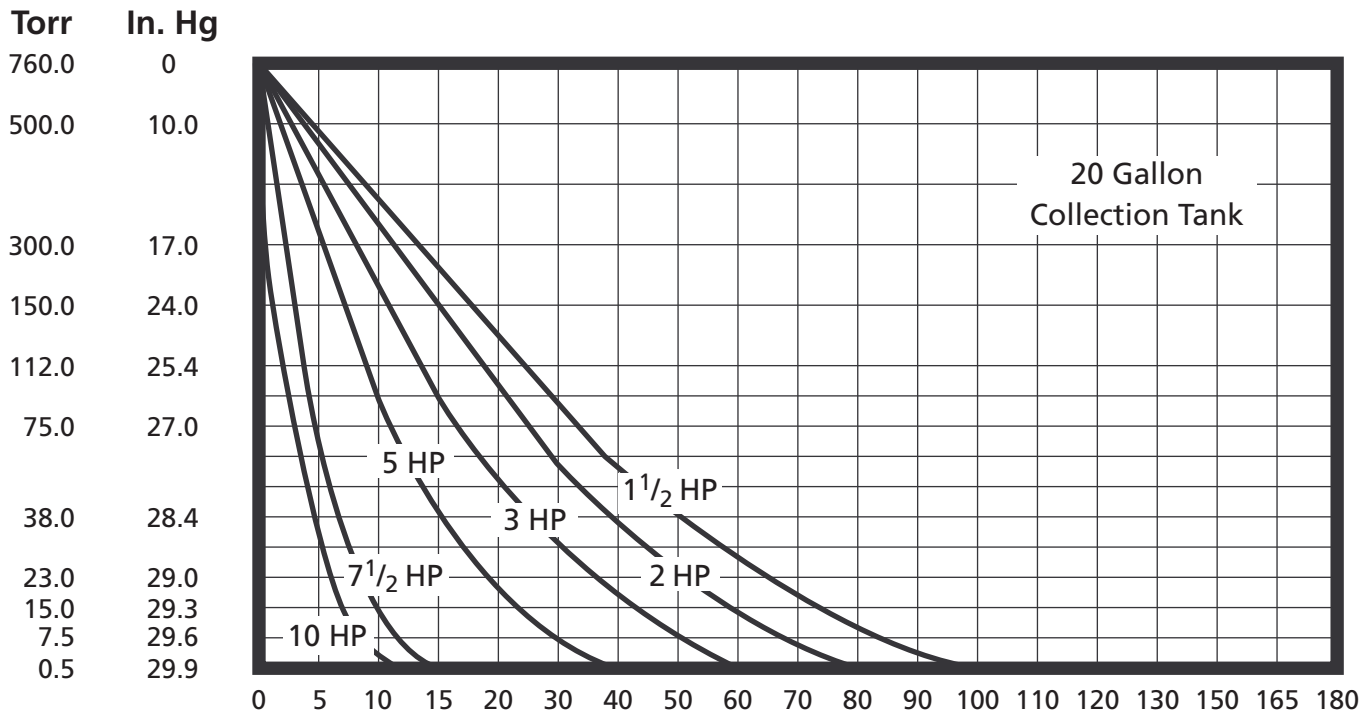

Vertical Tankmount Simplex

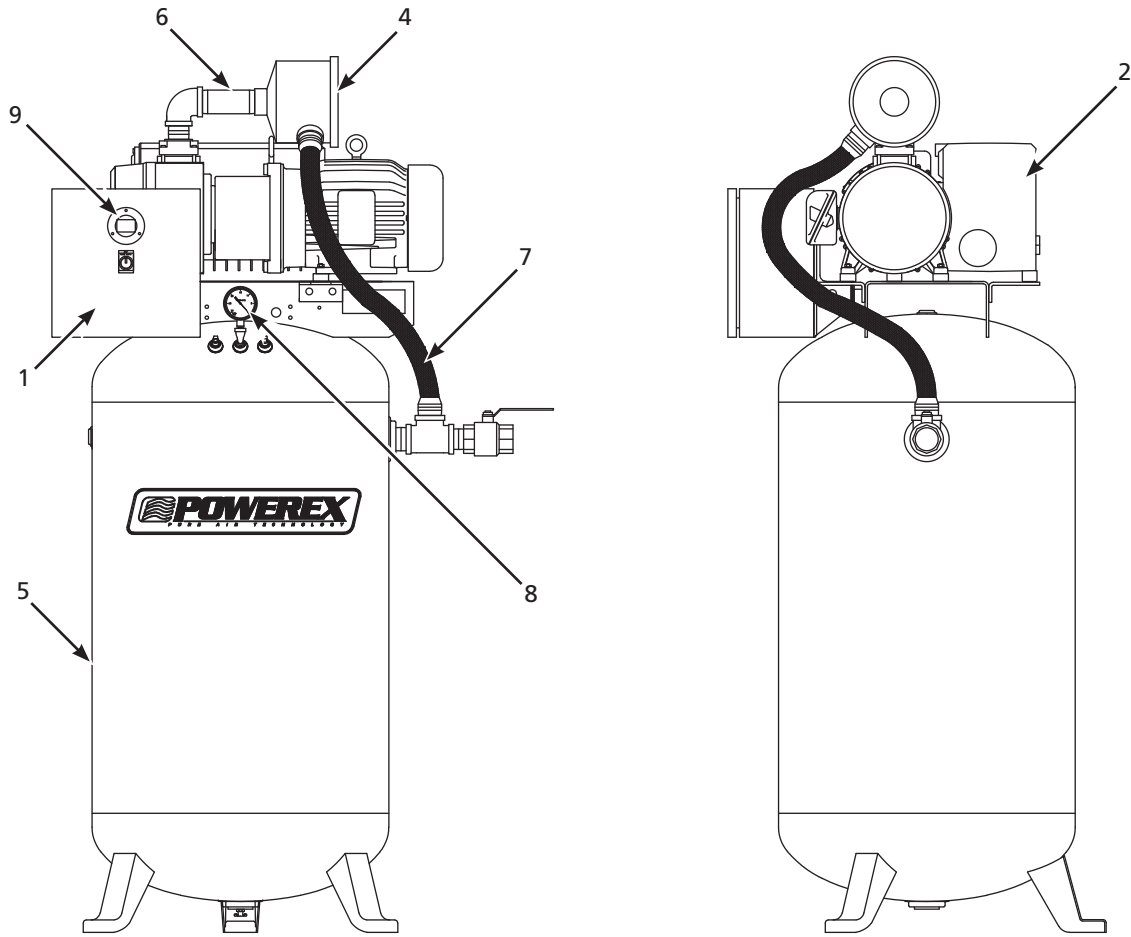

Ref. No.	Description	IVS015	IVS020	IVS030	Qty.
1	Motor starter 208V	PVI10012AJ	PVI10022AJ	PVI10032AJ	1
	Motor starter 230V	PVI10013AJ	PVI10023AJ	PVI10033AJ	1
	Motor starter 460V	PVI10014AJ	PVI10024AJ	PVI10034AJ	1
2	Vacuum pump / motor assembly	VPB01500AV	VPB02000AV	VPB03000AV	1
3	Vacuum switch (not shown)	VP001303AV	VP001303AV	VP001303AV	1
4	Inlet air filter element	VP000509AV	VP000509AV	VP000509AV	1
5	Receiver tank 30 gal.	AR024200ST	-	-	1
	Receiver tank 60 gal.	AR231601ST	AR231601ST	-	1
	Receiver tank 80 gal.	-	-	TF006607ST	1
6	Check valve	VP00406AV	VP00406AV	VP00406AV	1
7	Vacuum hose	HA001301AV (3FT)	HA001301AV (3FT)	HA001301AV (3FT)	1
8	Vacuum gauge	GA031600AV	GA031600AV	GA031600AV	1
9	Hour meter	PE001004AV	PE001004AV	PE001004AV	1
	Oil	VP000801AJ	VP000801AJ	VP000801AJ	1
	Oil filter	0531.002.00	0531.002.00	0531.002.00	1
	Separator filter	V532.140.156	V532.140.156	-	1
		-	-	V532.917.861	2

Horizontal Tankmount Simplex

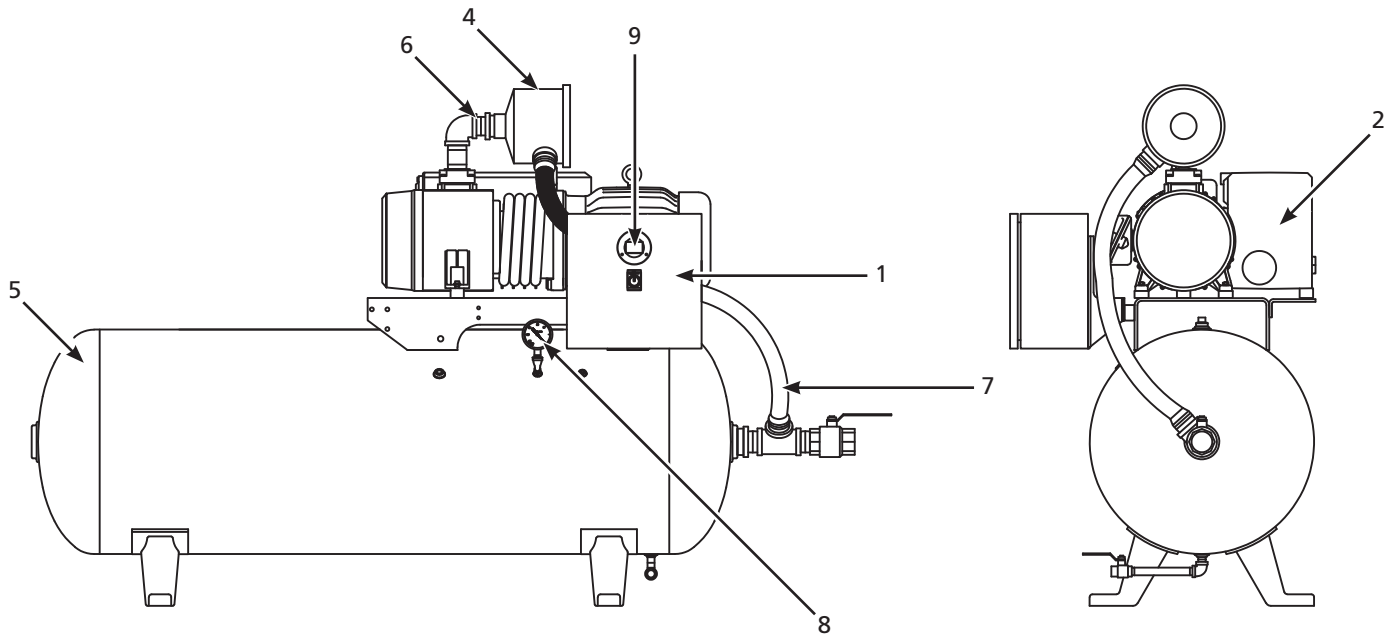

Ref. No.	Description	IVS040	IVS050	IVS075	IVS100	Qty.
1	Motor starter 208V	PVI10052AJ	PVI10052AJ	PVI10072AJ	PVI100A2AJ	1
	Motor starter 230V	PVI10053AJ	PVI10053AJ	PVI10073AJ	PVI100A3AJ	1
	Motor starter 460V	PVI10054AJ	PVI10054AJ	PVI10074AJ	PVI100A4AJ	1
2	Vacuum pump/ motor assembly	VPB05001AV	VPBK0500AV	VPB07500AV	VPB10000AV	1
3	Vacuum switch (not shown)	VP001303AV	VP001303AV	VP001303AV	VP001303AV	1
4	Inlet air filter element	VP000509AV	VP000509AV	VP000510AV	VP000510AV	1
5	Receiver tank 80 gal.	AR023400ST	AR023400ST	-	-	1
	Receiver tank 120 gal.	-	-	AR022400ST	-	1
	Receiver tank 200 gal.	-	-	-	JQ000200AJ	1
6	Check valve	VP00406AV	VP00406AV	VP00407AV	VP00407AV	1
7	Vacuum hose	HA001301AV (3FT)	HA001301AV (3FT)	HA001301AV (3FT)	HA001301AV (3FT)	1
8	Vacuum gauge	GA031600AV	GA031600AV	GA031600AV	GA031600AV	1
9	Hour meter	PE001004AV	PE001004AV	PE001004AV	PE001004AV	1
	Oil	VP000801AJ	-	-	-	1
		-	3SS-100G	VP000801AJ	VP000801AJ	2
	Oil filter	531.002.00	-	0531.000.001	0531.000.001	1
	Separator filter	V532.917.861	96541500000	-	-	2
		-	-	V532.917.862	V532.917.862	4

Horizontal Tankmount Duplex

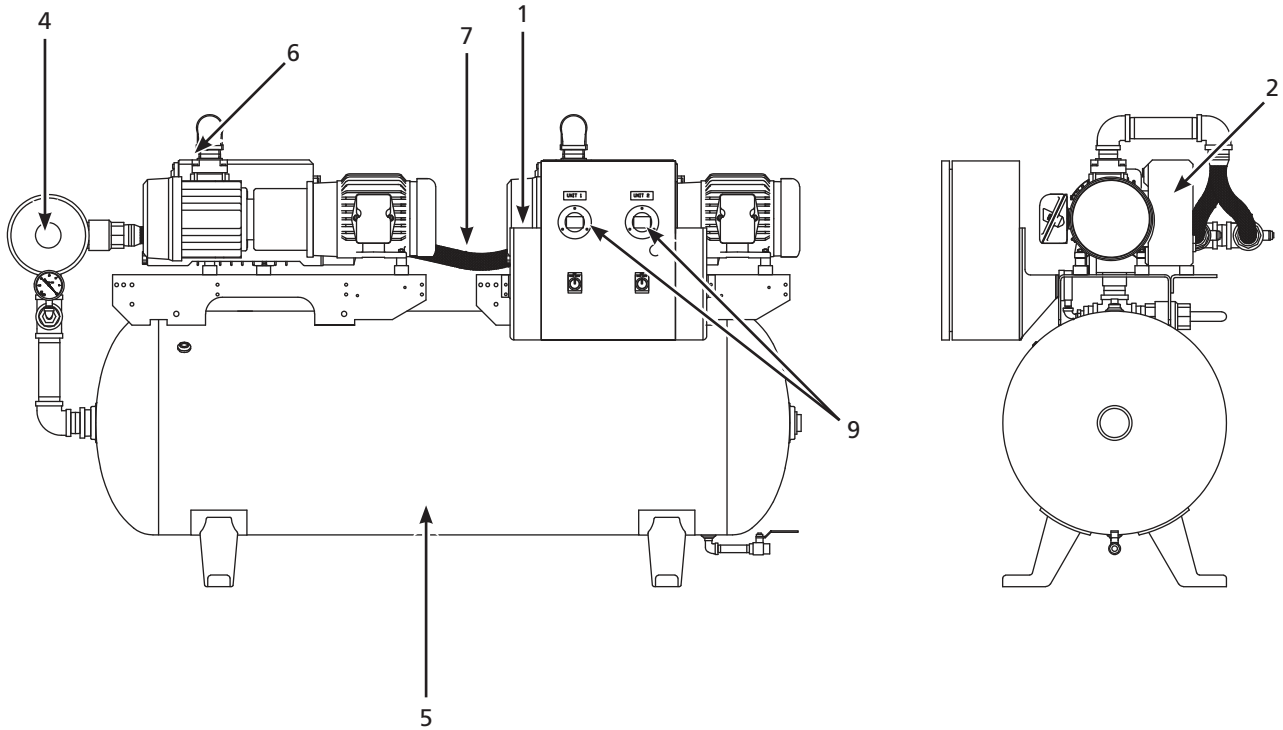

Ref. No.	Description	IVD015	IVD020	IVD030	Qty.
1	Motor starter 208V	PVI20012AB	PVI20022AB	PVI20032AB	1
	Motor starter 230V	PVI20013AB	PVI20023AB	PVI20033AB	1
	Motor starter 460V	PVI20014AB	PVI20024AB	PVI20034AB	1
2	Vacuum pump / motor assembly	VPB01500AV	VPB02000AV	VPB03000AV	2
3	Vacuum switch (not shown)	VP001303AV	VP001303AV	VP001303AV	2
4	Inlet air filter element	VP000509AV	VP000509AV	VP000510AV	1
5	Receiver tank (horizontal)	AR023400ST (80 gal.)	AR023400ST (80 gal.)	AR022400ST (120 gal.)	1
	Receiver tank (vertical)	TF006607ST (80 gal.)	TF006607ST (80 gal.)	TF006607ST (80 gal.)	1
		-	-	AR061400ST (120 gal.)	1
6	Check valve	VP000404AV	VP000404AV	VP00406AV	2
7	Vacuum hose	HA001300AV (6FT)	HA001300AV (6FT)	HA001301AV (6FT)	1
8	Vacuum gauge (not shown)	GA031600AV	GA031600AV	GA031600AV	1
9	Hour meter	PE001004AV	PE001004AV	PE001004AV	1
	Oil	VP000801AJ	VP000801AJ	-	
		-	-	VP000801AJ	2
	Oil filter	0531.002.00	0531.002.00	0531.002.00	2
	Separator filter	V532.140.156	V532.140.156	-	2
		-	-	V532.917.861	4

Horizontal Tankmount Duplex

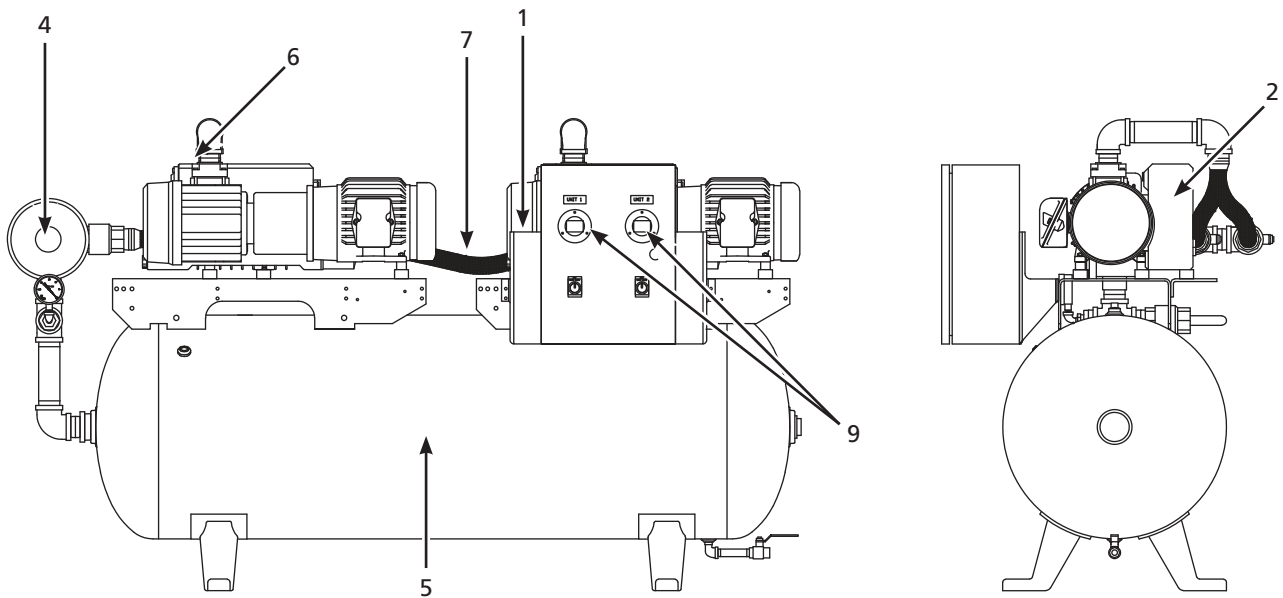

Ref. No.	Description	IVD040	IVD050	IVD075	IVD100	Qty.
1	Motor starter 208V	PVI20052AB	PVI20052AB	PVI20072AB	PVI200A2AB	1
	Motor starter 230V	PVI20053AB	PVI20053AB	PVI20073AB	PVI200A3AB	1
	Motor starter 460V	PVI20054AB	PVI20054AB	PVI20074AB	PVI200A4AB	1
2	Vacuum pump/ motor assembly	VPB05001AV	VPBK0500AV	VPB07500AV	VPB10000AV	2
3	Vacuum switch (not shown)	VP001303AV	VP001303AV	VP001303AV	VP001303AV	2
4	Inlet air filter element	VP000509AV	VP000510AV	VP000510AV	VP000510AV	1
5	Receiver tank (horizontal)	AR022800ST (120 gal.)	AR022800ST (120 gal.)	-	-	1
		-	JQ000200AJ (200 gal.)	JQ000200AJ (200 gal.)	-	1
		-	-	-	JQ000100AJ (240 gal.)	1
	Receiver tank (vertical)	AR027300ST (80 gal.)	-	-	-	1
		AR061400AV (120 gal.)	-	-	-	1
6	Check valve	VP00406AV	VP00406AV	VP00407AV	VP00407AV	2
7	Vacuum hose	HA001301AV (6FT)	HA001301AV (6FT)	HA001301AV (6FT)	HA001301AV (6FT)	1
8	Vacuum gauge	GA031600AV	GA031600AV	GA031600AV	GA031600AV	1
9	Hour meter (not shown)	PE001004AV	PE001004AV	PE001004AV	PE001004AV	2
	Oil	VP000801AJ	-	-	-	2
		-	3SS-100G	VP000801AJ	VP000801AJ	4
	Oil filter	531.002.00	N/A	0531.000.001	0531.000.001	2
	Separator filter	V532.917.861	96541500000	-	-	4
		-	-	V532.917.862	V532.917.862	8

Powerex Limited Warranty

Warranty and Remedies.

(a) General. Powerex warrants each Compressor System, Vacuum System, Vacuum Pump, Compressor Air-End, or Powerex branded Accessory (collectively "Products", individually each a "Product") to be free from defects in material and workmanship ("Defects") at the date of shipment. EXCEPT AS SET FORTH BELOW, NO OTHER WARRANTY, WHETHER EXPRESS OR IMPLIED, INCLUDING ANY WARRANTY OF MERCHANTABILITY OR FITNESS FOR A PARTICULAR PURPOSE, SHALL EXIST IN CONNECTION WITH THE SALE OR USE OF SUCH PRODUCTS. TO THE EXTENT PERMITTED BY LAW, ANY AND ALL IMPLIED WARRANTIES ARE EXCLUDED. All claims under this warranty must be made in writing and delivered to Powerex, or such claim shall be barred. Upon timely receipt of a claim, Powerex shall inspect the Product claimed to have a Defect, and Powerex shall repair, or, at its option, replace, free of charge, any Product which it determines to have had a Defect at the time of shipment from Powerex; provided, however, that if circumstances are such as to preclude the remedying of Defect by repair or replacement, Powerex shall, upon return of the Product, refund to buyer any part of the purchase price of such Products paid to Powerex. Freight for returning Products to Powerex for inspection shall be paid by buyer. The warranties and remedies herein are the sole and exclusive remedy for any breach of warranty or for any other claim based on any Defect, or non-performance of the Products, whether based upon contract, warranty or negligence.

b) Initial Period of Warranty – Parts and Labor. Powerex warrants and represents all Products shall be free from Defects for the first twelve (12) months from the date of shipment by Powerex, or five thousand (5,000) hours of use, whichever occurs first. During such warranty period, Powerex shall be fully liable for all Defects in the Products (the "Product Defects"), i.e., all costs of repair or replacement, which may include "in and out" charges, so long as the Products are located in the continental United States, and the Products are reasonably located and accessible by service personnel for removal. "In and out" charges include the costs of removing a Product from buyer's equipment for repair or replacement.

(c) Additional Period of Warranty – Parts Only (No Labor). In addition to the above, Powerex warrants each Powerex branded Compressor Air-End, and Vacuum Pump shall be free of Defects for a period of thirty-six months from the date of shipment of Product, or 10,000 hours of use, whichever occurs first. Supplier's repair or replacement of any Product shall not extend the period of any warranty of any Product. This warranty applies to the exchange of part(s) found to be defective by an Authorized Powerex Service Center only.

(d) Coverage. The above mentioned warranty applies to Powerex manufactured units or systems only.

(e) Exceptions. Notwithstanding anything to the contrary herein, Powerex shall have no warranty obligations with respect to Products:

- (i) that have not been installed in accordance with Powerex's written specifications and instructions;
- (ii) that have not been maintained in accordance with Powerex's written instructions;
- (iii) that have been materially modified without the prior written approval of Powerex; or
- (iv) that experience failures resulting from operation, either intentional or otherwise, in excess of rated capacities or in an otherwise improper manner.

(f) The warranty provided herein shall not apply to: (i) any defects arising from corrosion, abrasion, use of insoluble lubricants, or negligent attendance to or faulty operation of the Products; (ii) ordinary wear and tear of the Products; or (iii) defects arising from abnormal conditions of temperature, dirt or corrosive matter; (iv) any OEM component which is shipped by Powerex with the original manufacturer's warranty, which shall be the sole applicable warranty for such component.

Limitation of Liability. TO THE EXTENT ALLOWABLE UNDER APPLICABLE LAW, NOTWITHSTANDING ANYTHING TO THE CONTRARY HEREIN, UNDER NO CIRCUMSTANCES SHALL POWEREX BE LIABLE FOR ANY INCIDENTAL, CONSEQUENTIAL, PUNITIVE, SPECULATIVE OR INDIRECT LOSSES OR DAMAGES WHATSOEVER ARISING OUT OF OR IN ANY WAY RELATED TO ANY OF THE PRODUCTS OR GOODS SOLD OR AGREED TO BE SOLD BY POWEREX TO BUYER. TO THE EXTENT ALLOWABLE UNDER APPLICABLE LAW, POWEREX'S LIABILITY IN ALL EVENTS IS LIMITED TO, AND SHALL NOT EXCEED, THE PURCHASE PRICE PAID.

Warranty Disclaimer. Powerex has made a diligent effort to illustrate and describe the Products in this literature accurately; however, such illustrations and descriptions are for the sole purpose of identification, and do not express or imply a warranty that the Products are merchantable, or fit for a particular purpose, or that the Products will necessarily conform to the illustrations or descriptions.

Product Suitability. Many jurisdictions have codes and regulations governing sales, construction, installation, and/or use of Products for certain purposes, which may vary from those in neighboring areas. While Powerex attempts to assure that its Products comply with such codes, it cannot guarantee compliance, and cannot be responsible for how the product is installed or used. Before purchase and use of a Product, please review the Product applications, and national and local codes and regulations, and be sure that the Product, installation, and use will comply with them.

Claims. Claims pertaining to the Products, with the exception of warranty claims, must be filed with Powerex within 6 months of the invoice date, or they will not be honored. Prices, discounts, and terms are subject to change without notice or as stipulated in specific Product quotations. All agreements are contingent upon strikes, accidents, or other causes beyond our control. All shipments are carefully inspected and counted before leaving the factory. Please inspect carefully any receipt of Products noting any discrepancy or damage on the carrier's freight bill at the time of delivery. Discrepancies or damage which obviously occurred in transit are the carrier's responsibility and related claims should be made promptly directly to the carrier. Returned Products will not be accepted without prior written authorization by Powerex and deductions from invoices for shortage or damage claims will not be allowed. **UNLESS OTHERWISE AGREED TO IN WRITING, THESE TERMS AND CONDITIONS WILL CONTROL IN ANY TRANSACTION WITH POWEREX** any different or conflicting terms as may appear on any order form now or later submitted by the buyer. All orders are subject to acceptance by Powerex.