

Oiless Tankmount Duplex

Please read and save these instructions. Read carefully before attempting to assemble, install, operate or maintain the product described. Protect yourself and others by observing all safety information. Failure to comply with instructions could result in personal injury and/or property damage! Retain instructions for future reference.

Description

The OTD Series Powerex Duplex Air Compressors have been designed and tested to meet the most demanding specifications for reliability in the pneumatic oil-free industry.

All Powerex air compressors have reliable operation and feature high quality construction and components. An unloading feature is included on all compressors to provide loadless starting. Powerex oilless pumps use composite piston technology, low compressor speeds and PTFE compression ring(s) at low maintenance costs.

All 2 through 15 HP models are also equipped with an auxiliary cooling fan and air control shroud to achieve low head temperatures, further minimizing ring wear.

Powerex compressor motors are NEMA Class B or better design. Single-phase motors have built-in overload protection and a DPST disconnect switch. Three-phase motors require a manual or magnetic starter and three overload heater coils which may be ordered as a factory mounted-and-wired option.

Features

- Oilless reciprocating compressor pump
- High efficiency ODP motors
- Three year warranty on compressor pump
- Optional Isolation pads
- Optional R134 dryer
- ASME tank
- UL listed controls (with optional panel)

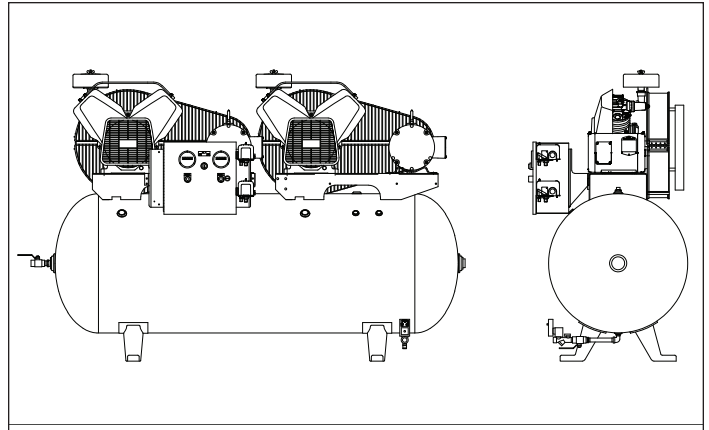

Specifications

Product	OTD Series Powerex Duplex Air Compressors
Performance Specifications	See Page 2
Lubrication	Grease Filled Bearings
Operating Voltages	1Ø 1 HP - 1-1/2 HP 115 - 280 / 230 Volts, 60 Hz 2 HP - 5 HP 280 / 230 Volts, 60 Hz 3Ø 280 - 230 / 460 Volts, 60 Hz
Compression Cycle	Single-Stage (1 HP - 3 HP Models) Two-Stage (5 HP - 15 HP Models)
Motor Overload Protection	1Ø Built-in Thermal Overload (Standard) 3Ø IEC Magnetic Starter with Adjustable Overload (Optional)
Pressure Settings	Lead Cut-In: Factory Set at Approx. 90 psig (621 kPa) Cut-Out: Factory Set at Approx. 120 psig (827 kPa) Lag Cut-In: Factory Set at Approx. 80 psig (552 kPa) Cut-Out: Factory Set at Approx. 110 psig (758 kPa)
Overpressure Protection	ASME Safety Valve Factory Set and Sealed
Outlet Air Connections	1/2 inch NPT (30, 60, and 80 Gallon Tanks) 1 inch NPT (120, 200 and 240 Gallon Tanks)
Tank Sizes	See Page 2
California Ordinance 462 (L) (2)	Meets Requirements of this Ordinance
Tank Isolation	Standard All Units
Drive	V Belt
Control Panel	Optional Panel UL508A Listed

The performance specifications are nominal and conform to acceptable industry standards. For application at conditions beyond these specifications, consult the local Powerex office. Powerex shall not be liable for damages resulting from misapplication or misuse of its products.

Performance Specifications

Model	HP	Phase	SCFM @ 100 psig	RPM	Voltage	Gallon Tank
OTD110	1 (2)	1	7.2	625	115 / 208 / 230	30 80
OTD010	1 (2)	3	7.2	625	208 / 230 / 460	30 80
OTD115	1-1/2 (2)	1	10.6	885	115 / 208 / 230	80
OTD015	1-1/2 (2)	3	10.6	885	208 / 230 / 460	80
OTD120	2 (2)	1	13.2	845	115 / 208 / 230	80
OTD020	2 (2)	3	13.2	845	208 / 230 / 460	80
OTD130	3 (2)	1	20.2	1115	208 / 230	80 120
OTD030	3 (2)	3	20.2	1115	208 / 230 / 460	80 120
OTD151	5 (2)	1	35.8	800	208 / 230	120 200
OTD050	5 (2)	3	35.8	800	208 / 230 / 460	120 200
OTD075	7.5 (2)	3	52.2	855	208 / 230 / 460	240
OTD100	10 (2)	3	70	1090	208 / 230 / 460	240
OTD150	15 (2)	3	108.4	1140	208 / 230 / 460	240

NOTE: See Electrical Diagram shipped with the unit for Motor Full Load Amp Ratings

Safety Guidelines

This manual contains information that is very important to know and understand. This information is provided for SAFETY and to PREVENT EQUIPMENT PROBLEMS. To help recognize this information, observe the following symbols.

⚠ DANGER *Danger indicates an imminently hazardous situation which, if not avoided, WILL result in death or serious injury.*

⚠ WARNING *Warning indicates a potentially hazardous situation which, if not avoided, COULD result in death or serious injury.*

⚠ CAUTION *Caution indicates a potentially minor or moderate injury.*

NOTICE *Notice indicates important information, that if not followed, may cause damage to equipment.*

NOTE: Information that requires special attention.

CALIFORNIA PROPOSITION 65

⚠ WARNING *This product or its power cord may contain chemicals known to the State of California to cause cancer and birth defects or other reproductive harm. Wash hands after handling.*

Installation

MOUNTED AND CONNECTED OPTIONS

Magnetic Motor Starter

An optional magnetic motor starter which has been selected and wired for the intended input voltage is available for all units. All starters are furnished with properly sized overload relay.

Refrigerated Air Dryer

A factory mounted refrigerated air dryer with automatic condensate drain trap assembly and bypass valve is available as an option on all 1/2 through 3 HP Powerex Duplex Air Compressors. The air dryer is piped to the compressor at the factory; power wiring to the dryer is done in the field using the integral cord and plug which fits into a standard 120 volt receptacle.

Automatic Tank Drain

Powerex air compressors are ordered with either a manual or electric type automatic tank drain. This unit is furnished with a manual drain as standard. An electric drain must be mounted to the compressor in the field.

Vibration Dampening Pads

Waffle type design vibration pads are provided as optional equipment.

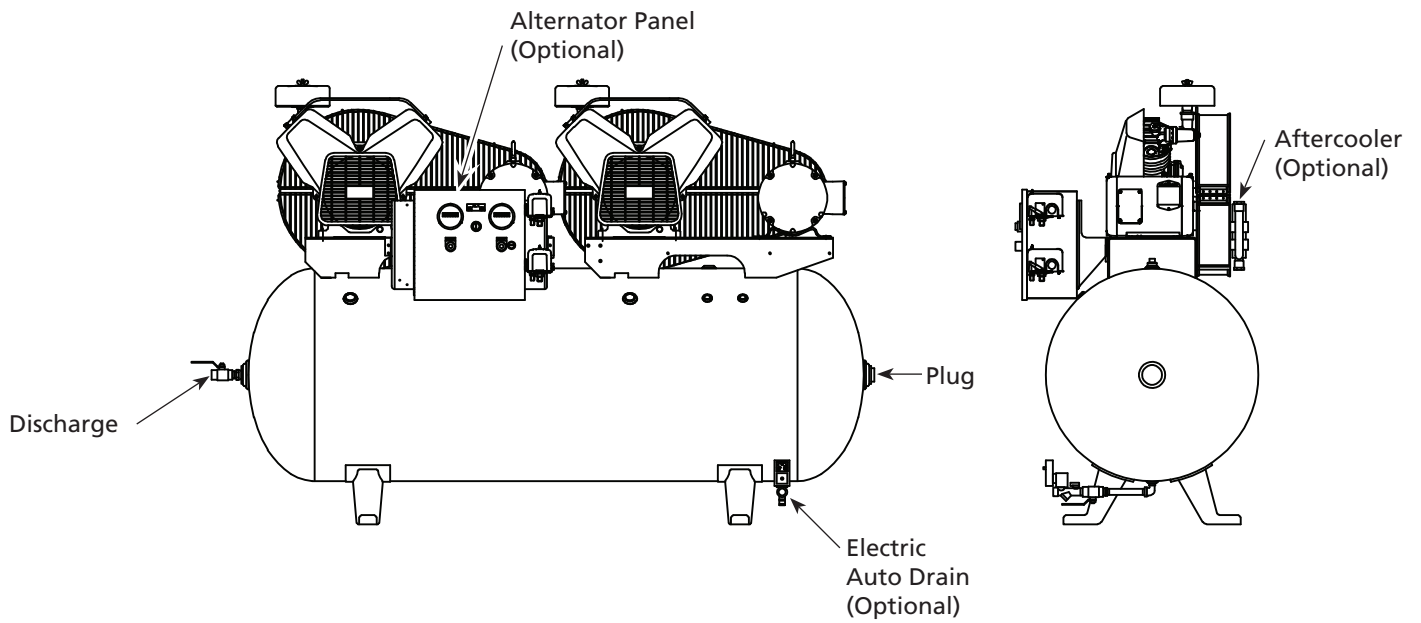

Figure 1 - 1.5 HP through 5 HP

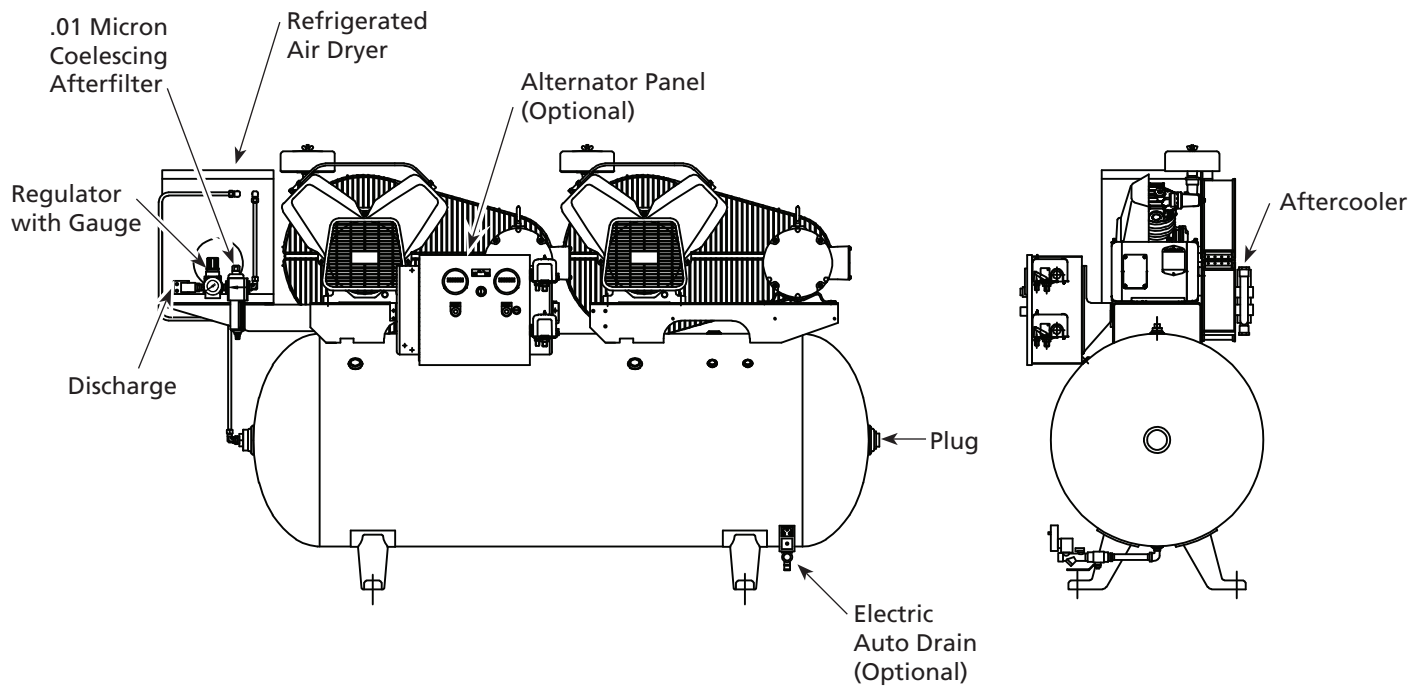

Figure 2 - 1.5 HP through 3 HP with Refrigerated Air Dryer Option

Oilless Tankmount Duplex

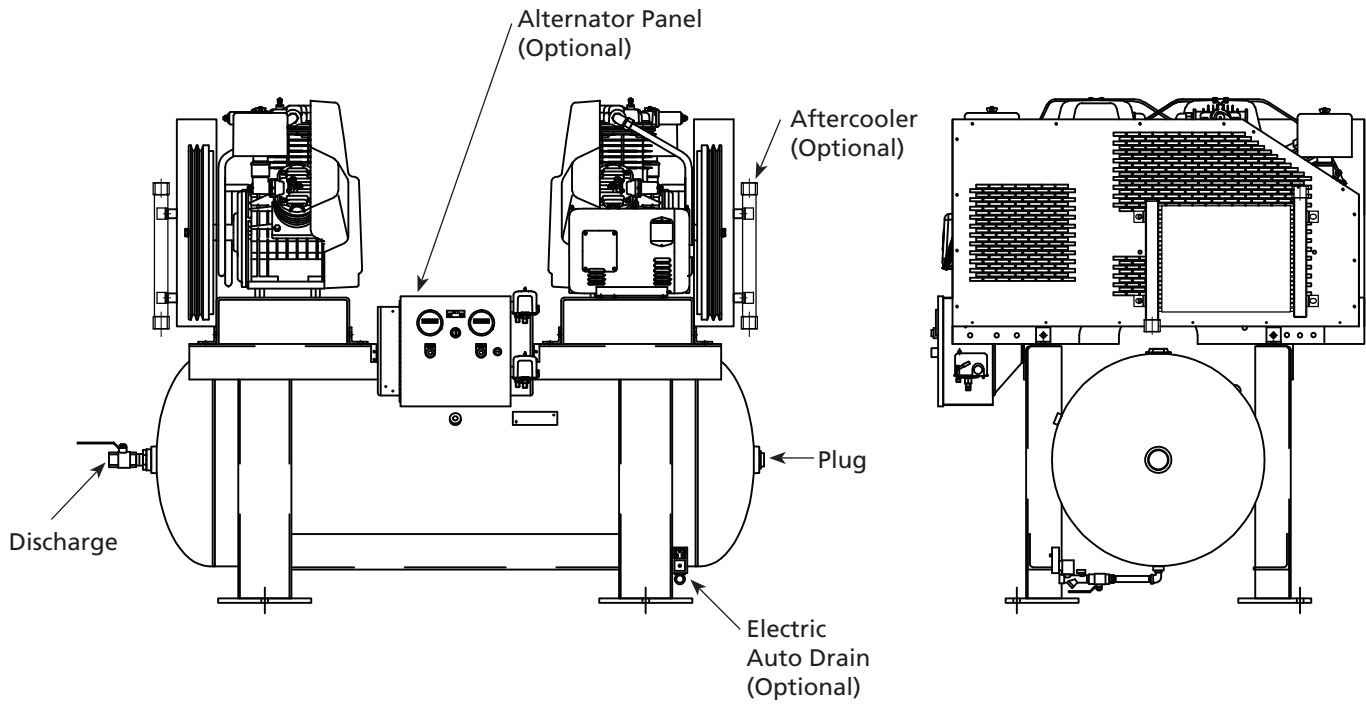

Figure 3 - 7.5 HP through 5 HP

Maintenance Schedule

Item	Action needed	Daily	Operating Hours						Remarks	
			500	1500	2500	5000	10,000	15,000		20,000
Tank	Drain moisture	●								Drain tank daily
Inlet air filter	Inspect, Replace		●		▲					Every 2500 hours or less
Blower fan	Clean					●	●	●	●	
Fan duct	Clean					●	●	●	●	
Compressor fins	Clean				●					Every 2500 hours or less
Compression rings	Inspect, Replace					●	▲	●	▲	Every 2500 hours or less
Wrist pin bearing	Regrease					▲	▲	▲	▲	Replace high pressure wrist pin
Piston set	Inspect					●			●	
V-belt	Inspect, Replace				●	▲	▲	▲	▲	See Note 3
Pressure switch	Confirm operation						●		●	
Magnetic starter	Inspect						●		●	Replace if contact points deteriorated
Safety valve	Confirm operation				●					Every 2500 hours or 6 months
Pressure gauge	Inspect				●					Every 2500 hours or less

- Inspect
- ▲ Replace

NOTES:

1. Inspect and perform maintenance periodically according to maintenance schedule.
2. The maintenance schedule relates to the normal operating conditions. If the circumstances and load condition are adverse, shorten the cycle time and do maintenance accordingly.
3. The tension of the V-belt should be adjusted during initial start up and inspected every 1,500 hours afterwards. Proper belt tension for 1 to 3 HP units is 2-3 lbs./0.5 inch deflection; for 5 to 15 HP units, 4-6 lbs./0.5 inch deflection.

Oilless Tankmount Duplex

Wiring Diagram

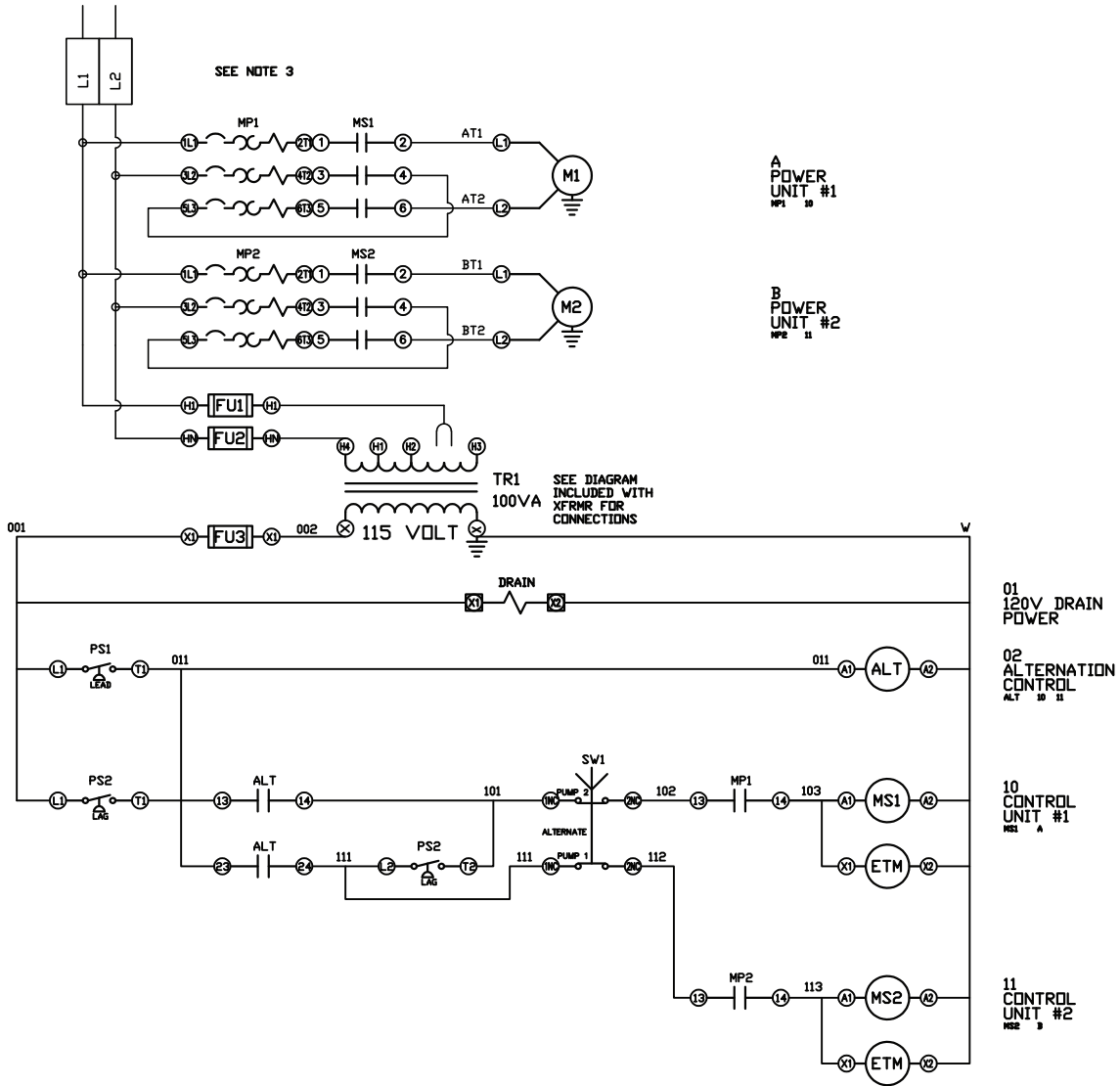

Figure 4 - Single Phase

Wiring Diagram

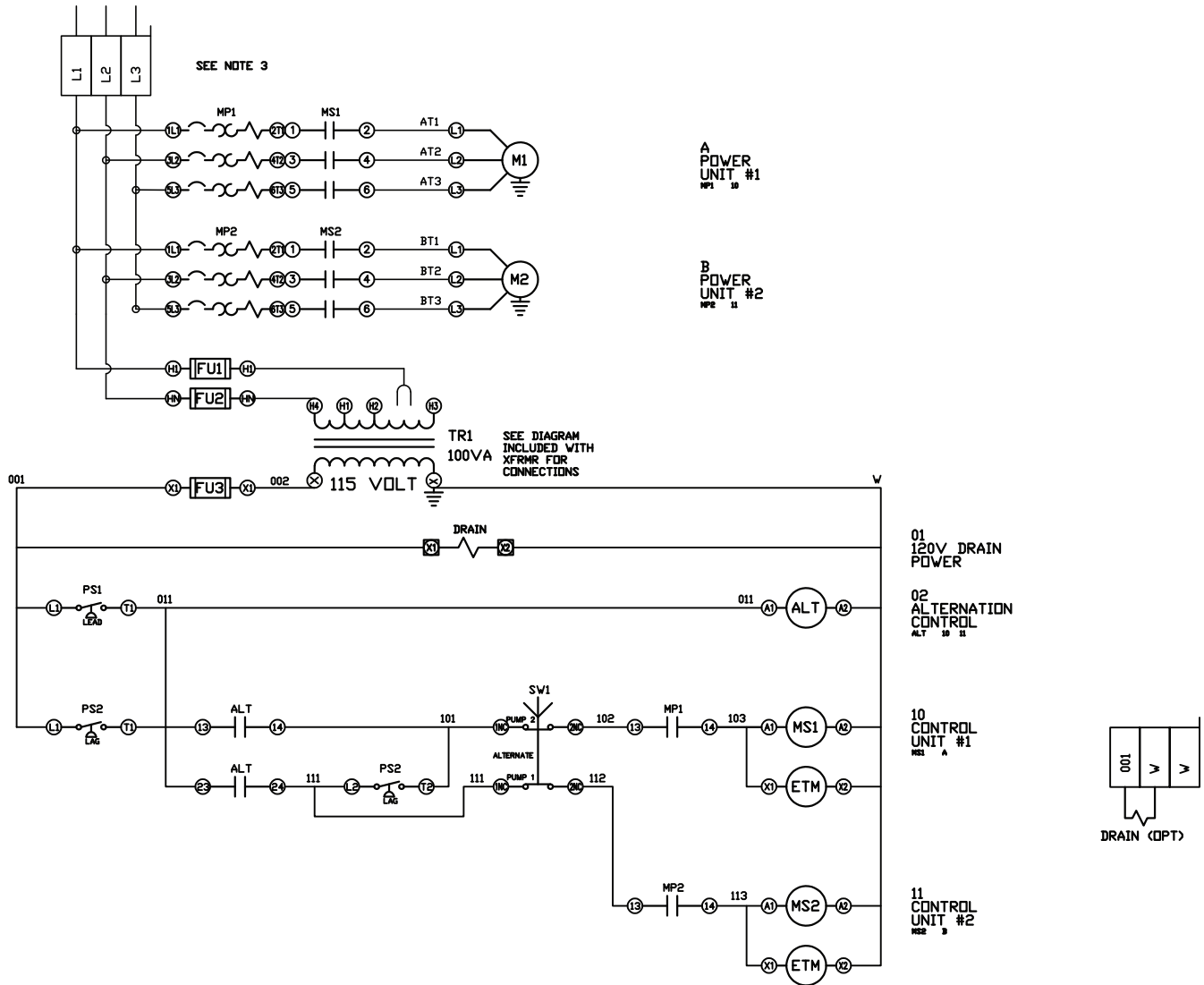
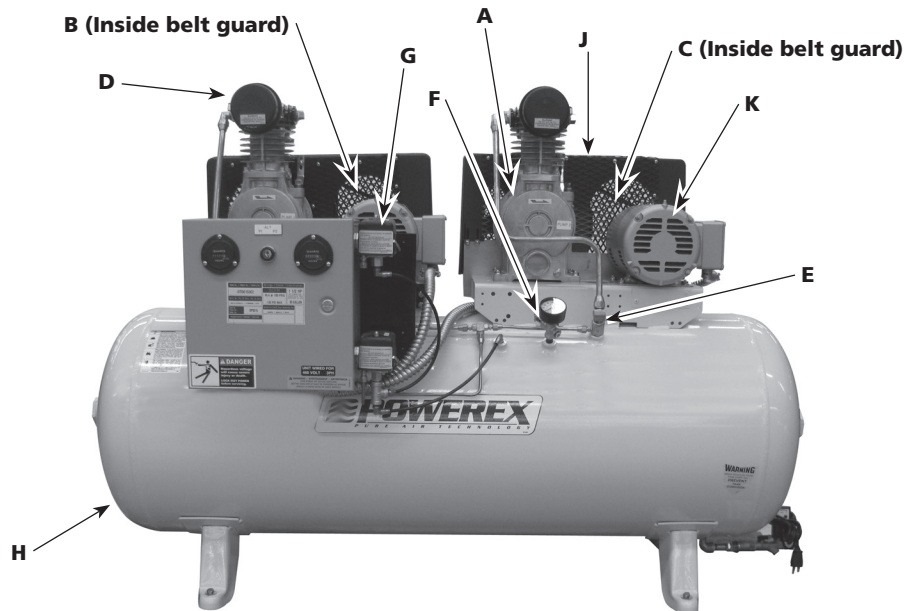

Figure 5 - Three Phase

Oilless Tankmount Duplex



Replacement Parts List

Item	Description	Quantity Required	Code Number		
A	PUMP AND FLYWHEEL: <u>Motor HP</u>	1, 1-1/2	2		
		2, 3	2		
		5	2		
		7-1/2, 10	2		
		15	2		
B †	BELT: <u>Motor HP</u>	Size			
		1 (1Ø)	2		
		1 (3Ø)	2		
		1-1/2	2		
		2	2		
		3	2		
		5 (120 gallon tank)	4		
		5 (200 gallon tank)	4		
		7-1/2	4		
		10	4		
		15	4		
C	MOTOR PULLEY: <u>Motor HP</u>	Type			
		1 (1Ø)	2		
		1 (3Ø)	2		
		1-1/2	2		
		2 (1Ø)	2		
		2 (3Ø)	2		
		3	2		
		5	2		
		7-1/2	2		
		10	2		
		15	2		
		D **	INTAKE FILTER ELEMENT <u>Motor HP</u>	1, 1-1/2	2
				2, 3	2
5	2				
7-1/2, 10	2				
15	2				
E	IN-TANK CHECK VALVE: <u>Motor HP</u>	Size			
		1 Through 3	2		
		5 Through 15	2		
			CV003204AV		
			CV003205AV		

Replacement Parts List (Continued)

Item	Description	Quantity Required	Code Number	
F	SAFETY RELIEF VALVE: Set at approximately 140 psig (965 kPa)			
	1 Through 5 HP Models	1	V-215100AV	
	7.5 Through 15 HP Models	1	V-215400AV	
G	PRESSURE ELECTRIC SWITCHES: (For all models)			
	Lead Switch: Set at approximately 90 psig (630 kPa) cut-in and 120 psig (827 kPa) cut-out	1	CW207558AV	
	Lag Switch: Set at approximately 80 psig (560 kPa) cut-in and 110 psig (758kPa) cut-out	1	CW207559AV	
H	TANK:			
	Motor HP	Tank Size		
	1 Through 1-1/2	30 gallon	1	AR022600ST
	2 & 3	80 gallon	1	AR022900ST
	3	120 gallon	1	AR023600ST
	5	120 gallon	1	AR022800ST
	5	200 gallon	1	JQ000200AJ
	7-1/2 Through 15	240 gallon	1	JQ000100AJ
J	BELT GUARD:			
	Motor HP			
	1 Through 1-1/2 (Whole Assembly: ZZ000605AJ)	2	BG012400AV	
	2, 3, 5	2	BG012802AV	
	7-1/2, 10 (Whole Assembly: ZZ000605AJ)	2	BG218500AV	
	15 (Whole Assembly: ZZ000620AJ)	2	BG218500AV	
K	MOTOR:			
	Motor HP			
	1 (1 Ø)	2	MC022371AV	
	1 (3 Ø)	2	MC301561AV	
	1-1/2 (1 Ø)	2	MC022320AV	
	1-1/2 (3 Ø)	2	MC303317AV	
	2 (1 Ø)	2	MC022317AV	
	2 (3 Ø)	2	MC303300AV	
	3 (1 Ø)	2	MC022309AV	
	3 (3 Ø)	2	MC303301AV	
	5	2	MC303303AV	
	7-1/2	2	MC303308AV	
	10	2	MC303310AV	
	15	2	MC303312AV	
L	Optional Refrigerated Dryer and Parts (not shown)			
	1HP			
	10 CFM Dryer	1	ACO016010	
	Regulator	1	ST178408	
	.01 µ Filter	1	ST178139	
	.01 µ Filter Element	1	ST178159	
	Electric Auto Tank Drain	1	SL300701AV	
	Beltguard Mounted Aftercooler *	2	SL300100AV	
	1.5-2HP			
	15 CFM Dryer	1	ACO016015	
	Regulator	1	ST178408AJ	
	.01 µ Filter	1	ST178139AV	
	.01 µ Filter Element	1	ST178159AV	
	Electric Auto Tank Drain	1	SL300701AV	
	Beltguard Mounted Aftercooler *	2	SL300100AV	
	3HP			
	25 CFM Dryer	1	ACO016025	
	Regulator	1	ST178409AJ	
	.01 µ Filter	1	ST178108AV	
	.01 µ Filter Element	1	ST178109AV	
	Electric Auto Tank Drain	1	SL300701AV	
Beltguard Mounted Aftercooler *	2	SL300100AV		

* = Part number includes only the Aftercooler. For complete Aftercooler Assembly, including mounting hardware and flex hoses, order part number ACO700015.

** = Replace every 2,500 hours

† = Replace every 5,000 hours

Powerex Limited Warranty

Warranty and Remedies.

(a) General. Powerex warrants each Compressor System, Vacuum System, Vacuum Pump, Compressor Air-End, or Powerex branded Accessory (collectively "Products", individually each a "Product") to be free from defects in material and workmanship ("Defects") at the date of shipment. EXCEPT AS SET FORTH BELOW, NO OTHER WARRANTY, WHETHER EXPRESS OR IMPLIED, INCLUDING ANY WARRANTY OF MERCHANTABILITY OR FITNESS FOR A PARTICULAR PURPOSE, SHALL EXIST IN CONNECTION WITH THE SALE OR USE OF SUCH PRODUCTS. TO THE EXTENT PERMITTED BY LAW, ANY AND ALL IMPLIED WARRANTIES ARE EXCLUDED. All claims under this warranty must be made in writing and delivered to Powerex, or such claim shall be barred. Upon timely receipt of a claim, Powerex shall inspect the Product claimed to have a Defect, and Powerex shall repair, or, at its option, replace, free of charge, any Product which it determines to have had a Defect at the time of shipment from Powerex; provided, however, that if circumstances are such as to preclude the remedying of Defect by repair or replacement, Powerex shall, upon return of the Product, refund to buyer any part of the purchase price of such Products paid to Powerex. Freight for returning Products to Powerex for inspection shall be paid by buyer. The warranties and remedies herein are the sole and exclusive remedy for any breach of warranty or for any other claim based on any Defect, or non-performance of the Products, whether based upon contract, warranty or negligence.

b) (i) Standard Period of Warranty – Parts and Labor – The purchase of any system includes our standard warranty. Powerex warrants and represents all Products shall be free from Defects for the first eighteen (18) months from the date of shipment by Powerex, or twelve (12) months from the documented date of startup, or five thousand (5,000) hours of use, whichever occurs first. During such warranty period, Powerex shall be fully liable for all Defects in the Products (the "Product Defects"), i.e., all costs of repair or replacement, which may include "in and out" charges, so long as the Products are located in the continental United States, and the Products are reasonably located and accessible by service personnel for removal. "In and out" charges include the costs of removing a Product from buyer's equipment for repair or replacement.

(ii) Premium Period of Warranty – Parts and Labor – In order to be eligible for premium warranty coverage, a premium warranty for each system must be purchased when order is placed. Powerex warrants and represents all Products shall be free from Defects for the first thirty (30) months from the date of shipment by Powerex, or twenty-four (24) months from the documented date of startup, or seven thousand five hundred (7,500) hours of use, whichever occurs first. During such warranty period, Powerex shall be fully liable for all Defects in the Products (the "Product Defects"), i.e., all costs of repair or replacement, which may include "in and out" charges, so long as the Products are located in the continental United States, and the Products are reasonably located and accessible by service personnel for removal. "In and out" charges include the costs of removing a Product from buyer's equipment for repair or replacement.

(c) Additional Period of Warranty – Parts Only (No Labor). In addition to the above, Powerex warrants each Powerex branded Compressor Air-End, and Vacuum Pump shall be free of Defects for a period of forty-two (42) months from the date of shipment by Powerex, or thirty-six (36) months from the documented date of startup, or ten thousand (10,000) hours of use, whichever occurs first. Supplier's repair or replacement of any Product shall not extend the period of any warranty of any Product. This warranty applies to the exchange of part(s) found to be defective by an Authorized Powerex Service Center only.

(d) Coverage. The above mentioned warranty applies to Powerex manufactured units or systems only.

(e) Exceptions. Notwithstanding anything to the contrary herein, Powerex shall have no warranty obligations with respect to Products:

- (i) that have not been installed in accordance with Powerex's written specifications and instructions;
- (ii) that have not been maintained in accordance with Powerex's written instructions;
- (iii) that have been materially modified without the prior written approval of Powerex; or
- (iv) that experience failures resulting from operation, either intentional or otherwise, in excess of rated capacities or in an otherwise improper manner.

(f) The warranty provided herein shall not apply to: (i) any defects arising from corrosion, abrasion, use of insoluble lubricants, or negligent attendance to or faulty operation of the Products; (ii) ordinary wear and tear of the Products; or (iii) defects arising from abnormal conditions of temperature, dirt or corrosive matter; (iv) any OEM component which is shipped by Powerex with the original manufacturer's warranty, which shall be the sole applicable warranty for such component.

Limitation of Liability. TO THE EXTENT ALLOWABLE UNDER APPLICABLE LAW, NOTWITHSTANDING ANYTHING TO THE CONTRARY HEREIN, UNDER NO CIRCUMSTANCES SHALL POWEREX BE LIABLE FOR ANY INCIDENTAL, CONSEQUENTIAL, PUNITIVE, SPECULATIVE OR INDIRECT LOSSES OR DAMAGES WHATSOEVER ARISING OUT OF OR IN ANY WAY RELATED TO ANY OF THE PRODUCTS OR GOODS SOLD OR AGREED TO BE SOLD BY POWEREX TO BUYER. TO THE EXTENT ALLOWABLE UNDER APPLICABLE LAW, POWEREX'S LIABILITY IN ALL EVENTS IS LIMITED TO, AND SHALL NOT EXCEED, THE PURCHASE PRICE PAID.

Warranty Disclaimer. Powerex has made a diligent effort to illustrate and describe the Products in this literature accurately; however, such illustrations and descriptions are for the sole purpose of identification, and do not express or imply a warranty that the Products are merchantable, or fit for a particular purpose, or that the Products will necessarily conform to the illustrations or descriptions.

Product Suitability. Many jurisdictions have codes and regulations governing sales, construction, installation, and/or use of Products for certain purposes, which may vary from those in neighboring areas. While Powerex attempts to assure that its Products comply with such codes, it cannot guarantee compliance, and cannot be responsible for how the product is installed or used. Before purchase and use of a Product, please review the Product applications, and national and local codes and regulations, and be sure that the Product, installation, and use will comply with them.

Claims. Claims pertaining to the Products, with the exception of warranty claims, must be filed with Powerex within 6 months of the invoice date, or they will not be honored. Prices, discounts, and terms are subject to change without notice or as stipulated in specific Product quotations. All agreements are contingent upon strikes, accidents, or other causes beyond our control. All shipments are carefully inspected and counted before leaving the factory. Please inspect carefully any receipt of Products noting any discrepancy or damage on the carrier's freight bill at the time of delivery. Discrepancies or damage which obviously occurred in transit are the carrier's responsibility and related claims should be made promptly directly to the carrier. Returned Products will not be accepted without prior written authorization by Powerex and deductions from invoices for shortage or damage claims will not be allowed. **UNLESS OTHERWISE AGREED TO IN WRITING, THESE TERMS AND CONDITIONS WILL CONTROL IN ANY TRANSACTION WITH POWEREX** any different or conflicting terms as may appear on any order form now or later submitted by the buyer. All orders are subject to acceptance by Powerex.