

Oil-less Vane Vacuum Systems

Please read and save these instructions. Read carefully before attempting to assemble, install, operate or maintain the product described. Protect yourself and others by observing all safety information. Failure to comply with instructions could result in personal injury and/or property damage! Retain instructions for future reference.

DESCRIPTION

GENERAL

Powerex Medical Vacuum Systems are designed to provide vacuum for hospitals and medical institutes. They are designed and constructed to meet NFPA 99 requirements for Level 1 piped vacuum systems. **If WAGD vacuum is the same as the medical-surgical vacuum source: Flammable anesthetics or flammable vapors shall be diluted below the flammable limit prior to disposal into the vacuum system or the pumps shall be designed of materials and using lubricants that are inert in the presence of oxygen, nitrous oxide, and halogenated anesthetics.**

SAFETY GUIDELINES

A SEPARATE SAFETY BOOKLET IS PROVIDED ALONG WITH THIS MANUAL. READ AND UNDERSTAND THE SAFETY BOOKLET. This manual contains information that is very important to know and understand. This information is provided for SAFETY and to PREVENT EQUIPMENT PROBLEMS. To help recognize this information, observe the following symbols. **MAKE SURE EVERYONE OPERATING OR SERVICING THE COMPRESSOR READS AND UNDERSTANDS ALL THE INFORMATION PROVIDED.**

⚠ DANGER *Danger indicates an imminently hazardous situation which, if not avoided, WILL result in death or injury.*

⚠ WARNING *Warning indicates a potentially hazardous situation which, if not avoided, COULD result in death or serious injury.*

⚠ CAUTION *Caution indicates a potentially hazardous situation which, if not avoided, MAY result in minor or moderate injury.*

NOTICE *Notice indicates important information, that if not followed, may cause damage to equipment.*

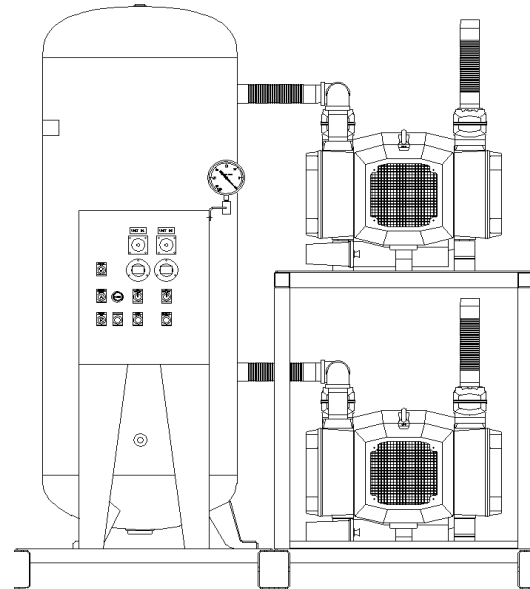

SPECIFICATIONS

Product	Oil-less Vane Vacuums
Operating Voltages	208V, 230V, 460V
Control Panel	UL508A and NFPA compliant
Motor	TEFC Electric Motor
Tank	ASME Rated for 200 psi MAWP
Drive	Direct
Tank Sizes	80 Gallon to 240 Gallon
Performance	See Cut Sheet

UNPACKING

Immediately upon receipt of the vacuum system, inspect for any damage which may have occurred during shipment. Repair or replace damaged items before use. The name-plate should be checked to verify the correct model and voltage.

⚠ WARNING *Do not operate unit if damaged during shipping, handling or use. Damage may result in bursting and cause injury or property damage.*

Oil-less Vane Vacuum Systems

COMPONENTS

VACUUM PUMPS

Powerex medical vacuum systems use electric motor driven oil-less rotary vane pumps to create vacuum for the removal of unwanted fluids and gases. The pumps remove the gases and exhaust them to atmosphere through the exhaust piping system.

Systems consist of multiple vacuum pumps that are automatically controlled and may be isolated using valves for service. One pump is used as the reserve. The control system will trigger alarm actions in accordance with NFPA 99 requirements if the capacity of the reserve pump is needed. The control system operates the available pumps in response to vacuum demand as determined by the vacuum switches or sensor. If needed, the controls will include minimum run timer functions to prevent frequent starting and stopping of the electric motors.

The vacuum pump assemblies are mounted with vibration isolation. Each vacuum pump has its own motor. The motors are mated to the vacuum pumps by a flange mounting and coupling system. Maintenance instructions are provided for the vacuum pumps and motors in the separate manual. Each vacuum pump has an intake assembly that includes an integral vacuum relief valve, exhaust silencer and a 4 micron, 5 micron or 10 micron inlet filter based on the pump being used. Each pump has an in-line check valve and an anti-reverse flow valve to prevent them from running backwards when off.

RECEIVER TANK

The receiver tank in a Powerex Medical Vacuum System is plumbed so that it sees the system vacuum. The ASME National Board registered air receiver is provided with a condensate drain. Manual drain valves are standard and optional vacuum auto drain set ups are available. Systems may be built with receivers separately mounted or with vacuum pumps and controls integrally mounted.

⚠ CAUTION

Factory installed receiver is used for vacuum capacity only and is NOT a collection receiver.

⚠ DANGER

Never drill holes in, or perform any welding on receiver tanks (unless qualified by ASME to do so) or use them beyond the rated pressure settings. Never mount other machinery or equipment on receivers.



STANDARD CONTROL PANEL

Built in a NEMA 4/12 enclosure, the controls are UL508A labeled and NFPA compliant. The panels have a single incoming power connection point and two control transformers with supplementary fused protected on primary and secondary circuits. Systems are designed for automatic alternation via PLC control. Systems with two to four motors utilize adjustable vacuum switches with backup low vacuum control circuit. Systems with five or more motors utilize a vacuum transducer. Each motor in the system is equipped with a magnetic starter and thru-door lockable motor protector disconnect.

All systems have a 30 minute alternation cycle with 10 minute minimum run timers for each pump to prevent short cycling and motor damage.

INSTALLATION

Disconnect, tag and lockout power before attempting to install, service, relocate or perform any maintenance.



CAUTION *Do not lift or move unit without appropriately rated equipment. Be sure the unit is securely attached to lifting device used. Do not lift unit by holding onto tubes or coolers. Do not use pumps to lift other attached equipment.*

WARNING *Installation of inlet/outlet air plumbing from the system and electrical connections must be in accordance with National Fire Protection Association (NFPA 99) Code Compliance for Medical Gas Breathing Air (Level 1).*

INSTALLATION SITE

1. The vacuum system must be located in a clean, well lit and well ventilated area.
2. The area should be free of excessive dust, toxic or flammable gases and moisture.
3. Never install the vacuum system where the surrounding temperature is higher than 104°F or where humidity is high.
4. Clearance must allow for safe, effective inspection and maintenance.

MINIMUM CLEARANCES	
Above	24 inches
Other sides	36 inches

5. If necessary, use metal shims or leveling pads to level the system. Never use wood to shim the unit.
6. The frame is drilled to allow bolting to the floor. Secure as necessary. Rubber composite isolation pads should be used to minimize transmission of noise and vibration to the building. Additional measures for isolation may be required. Drill a hole through the isolation pad and center it under the mounting point.
7. Some systems are built with multiple frames and must be installed and the air and electrical connections between the frames made at the time of installation. Be sure to install the system in the same configuration as shown on the system drawing so that the flexible connection hoses and electrical lines will fit.

VENTILATION

1. If the vacuum system is located in a totally enclosed room, an exhaust fan with access to outside air make up air must be installed.
2. Never restrict the cooling fan exhaust air. Maintain a minimum of 2 feet of clearance around the entire unit.
3. Never locate the vacuum system where hot exhaust air from other heat generating units may be pulled into the unit.

WIRING

DANGER *Lock out and tag out the electrical supply before servicing the equipment.*



DANGER *Electrical shock hazard. Make sure the system is grounded in accordance with NEC and local requirements.*



All electrical hook-ups must be performed by a qualified electrician. Installations must be in accordance with local and national electric codes. Make sure power supply conductors are sized adequately for full system demand.

PIPING

The system may have temporary shipping supports in place. These should be removed when the system piping is connected to the building piping. Appropriate supports should be added to the system when building tie in is completed.

The system has a single point inlet with a flexible connector. Each pump is supplied with a flexible connector for tying in to the system exhaust. A drip leg and a drain valve are provided near the exhaust fitting of each vacuum pump. The drip leg must prevent collected condensation from draining back into the pump or pumps.

1. Make sure the piping is lined up without being strained or twisted when assembling the piping for the system.
2. The exhaust piping should be kept short and have the least restriction possible. The flex connector supplied by Powerex may be repositioned (changed from vertical to horizontal and the elbow turned or removed) if desired to achieve a more effective installation to match the field installed exhaust piping. Repositioning is desirable if the final system plumbing design can be shorter by doing so.
3. Never use any piping smaller than the pump connection. To determine the minimum required pipe size for a vacuum system exhaust, calculate the equivalent straight length of the run. Never use a pipe size smaller than the flex connector supplied by Powerex or smaller than the size shown in the 100 foot column on the chart for the CFM of the pump. The equivalent straight length is the length of all the pipe needed from the flex connector to the final outlet plus a factor for each elbow, cross or tee. Pipe must be smooth ID. If rough pipe is used, increase by one size.
4. If a grating or grille is used at the end of the exhaust pipe, make sure its open area is at least equal to the area of the exhaust pipe.

Oil-less Vane Vacuum Systems

Pipe Size Requirements			
System CFM	Minimum Pipe Size for 100 feet	Minimum Pipe Size for 300 feet	Minimum Pipe Size for 600 feet
5	1.0	1.25	1.5
7	1.0	1.25	1.5
11	1.25	1.5	1.5
21	1.25	1.5	1.5
26	1.25	1.5	2.0
32	1.25	1.5	2.0
38	1.5	2.0	2.5
52	1.5	2.0	2.5
58	1.5	2.5	2.5
63	2.0	2.5	2.5
65	2.0	2.5	3.0
87	2.0	2.5	3.0
104	2.0	3.0	3.5
111	2.5	3.0	3.5
154	2.5	3.0	3.5
156	2.5	3.5	4.0
168	2.5	3.5	4.0
195	3.0	3.5	4.0
258	3.0	3.5	4.0
260	3.5	4.0	5.0
387	3.5	4.0	5.0
516	4.0	5.0	6.0

Approximate system CFM equals the number of pumps running times CFM in table below. (Data below is for reference only, if actual pump CFM is higher than shown, use the higher value.)

HP	Vane Pump CFM @ 19"	Claw Pump CFM @ 19"
1.0	5	
1.5	7	
2.0	11	16
3.0	17	21
4.0		29
5.0	26	
5.0	38	
5.4		38
6.4		52
7.5	52	65
8.7		77
10.0	65	84
10.0	77	
15.0	111	129
20.0	137	
25.0	168	

If the system extends beyond 600 equivalent straight feet, use one size larger pipe.

Pipe Size	Equivalent length for 90° elbow, cross, or tee	Equivalent length for 45° elbow
	3.0 feet	1.5 feet
1.5	3.75 feet	1.8 feet
2.0	5.0 feet	2.5 feet
2.5	6.25 feet	3.1 feet
3.0	7.5 feet	3.8 feet
3.5	8.78 feet	4.4 feet
4.0	10.0 feet	5.0 feet
5.0	12.5 feet	6.25 feet

OPERATION

BEFORE START UP

1. Make sure all safety warnings, labels and instructions have been read and understood before continuing.
2. Remove any shipping materials, brackets, etc.
3. Ensure all fuses, circuit breakers, etc., are properly sized.
4. Confirm electric power source and ground have been firmly connected. Make sure the electrical control box door is closed and latched.
5. Make sure all piping is connected. Open the isolation valves for each vacuum pump. Open the valve to the receiver. Close the receiver drain valve.
6. Make sure all selector switches on the control panel are OFF.

⚠WARNING

Risk of injury. Make sure no one is in contact with any moving parts during the rotation check.



7. Energize the main electric power. Visually check rotation of each vacuum pump by bumping (momentarily turning on and then off) using the “Hand” position of the selector switch on the control panel. If rotation is incorrect, have a qualified electrician correct wiring to reverse the rotation.

NOTICE

If all pumps are running in the wrong direction, change the incoming power leads to correct rotation.

START-UP AND OPERATION

1. Follow all procedures under “Before Start-Up” before attempting operation of the vacuum pump.
2. Make sure all selector switches are in the OFF position.
3. Switch on electric source.
4. Open tank connection valve or valves completely.
5. Using the selector switches on the control panel, turn on each pump—motor in the “Auto” mode until all are running.
6. Check the vacuum level using the system gauge. The control system will turn off the vacuum pump motors when the vacuum level is maintained and the minimum run timer conditions are satisfied.
7. Check for excessive vibration, unusual noises or leaks during operation. If problems are detected, shut down the system and make corrections or repair as needed before operating the system.
8. Pumps may be operated in “Hand” mode to override the function of the automatic controls. The pumps and the system will not be damaged during “hand” mode operation. The pumps are equipped with automatic vacuum limiting valves if needed to avoid damage.
9. In normal operation, leave all selector switches in the

“Auto” position and allow the controls to cycle the pumps as needed based on vacuum demand.

NOTICE

Switch breaker OFF if vacuum pump will not be used for a long period of time.

SEQUENCE OF OPERATIONS

All vacuum pumps will operate on a 10 minute minimum run timer (to prevent the short cycling of pumps) and will alternate Lead, Lag, etc., every 30 minutes, unless interrupted by the Lead/Lag Freeze (see example below).

For example, a vacuum switch closes 25 minutes into the 30 minute alternation sequence; pump 1 is activated and held on for its 10 minute minimum run time. The alternation sequence will be extended to a total of 35 minutes. During the following 30 minutes, if a vacuum switch closes, pump 2 will be activated and held on for its 10 minute run time. This operation is referred to as the Lead/Lag Freeze. Its purpose is to prevent short cycling of pumps in the event that a vacuum switch is activated at the end of an alternation period.

The Reserve (or last Lag) Vacuum Switch will bring on the reserve or last pump in the system and activate the Reserve Pump in Use Alarm.

The Vacuum Switch(es) are factory set to the system specifications. It is not recommended to adjust the settings in the field. An adjustment to the setting could result in inconsistent PLC operation and possible malfunction of the system controls. Please consult your service contractor if adjustments are required.

Oil-less Vane Vacuum Systems

MAINTENANCE

Refer to the manual from the vacuum pump manufacturer.

Pump Models	Item	Remarks	Service Interval
VO001502AV (VT4.25)	1. Air Intake Filter	1. Check and clean. Replace if necessary.	2,000 hrs
VO001503AV (VT4.40)	2. Pump Vanes	2. Check vanes. Replace if less than 34mm width.	
VO001602AV (KVT3.10)	1. Air Intake Filter	1. Air intake filter.	2,000 hrs
VO001603AV (KVT3.14)	2. Discharge Filter (if installed)	2. Check and replace if necessary.	
VO001600AV (KVT3.60)	3. PTFE composite tube seals in end shield	3. If the hollow center shows through, replace.	
VO001601AV (KVT3.80)	4. Grease	4. Apply grease to bearing in end shield. (Use only Amblygon TA 15/2 grease.)	
VO001704AV (VTLF2.250)	5. Secondary cooling filter	5. Check and replace if necessary.	
	6. Pump vanes	6. Check vanes. Replace if less than: 27mm for VO001602AV (KVT3.10) 32mm for VO001603AV (KVT3.14) 27mm for VO001600AV (KVT3.60) 27mm for VO001601AV (KVT3.80) 41mm for VO001704AV (VTLF2.250)	
All models	1. Drip leg drain	Open and allow to drain and check for proper working order.	100 hrs
All models	1. Vacuum switch	Inspect.	5,000 hrs 10,000 hrs 15,000 hrs 20,000 hrs

NOTES:

1. Inspect and perform maintenance periodically according to the maintenance schedule.
2. The maintenance schedule relates to the normal operating conditions. If the circumstances and load condition are adverse, shorten the cycle time and perform maintenance accordingly.

TROUBLESHOOTING GUIDE (Chart 7)

Problem	Cause	Corrective Action
Lag Alarm	Overload Tripped	<ol style="list-style-type: none"> 1. Reset overload; if problem continues, check motor amp draw 2. Verify overload is set to the correct value (see electrical drawing) 3. Verify wire gauge is correct for amp draw
	PLC Failure	<ol style="list-style-type: none"> 1. Check PLC for red error light; replace PLC 2. Check PLC for flashing green light; if 24V DC is present on the last input, then reprogram PLC with E-Prom chip
	Pump/Motor Failure	<ol style="list-style-type: none"> 1. Check drive coupling; replace if needed. 2. Verify that pump shaft turns freely; repair or replace as necessary 3. Check vacuum discharge piping to verify air is being exhausted; repair or replace as necessary 4. Verify voltage to the motor; repair wiring or replace motor as necessary
	Vacuum Consumption	<ol style="list-style-type: none"> 1. Repair leaks 2. Inspect purge valves are closing; repair or replace as necessary
	Switch Failure	Check continuity on lead vacuum switch
High Temperature Alarm	High Temperature	Verify ambient temperature is below 104°F
	Lost Connection	Inspect high temperature probe and connections; replace if necessary

Notes

Powerex Limited Warranty

Warranty and Remedies.

(a) General. Powerex warrants each Compressor System, Vacuum System, Vacuum Pump, Compressor Air-End, or Powerex branded Accessory (collectively "Products", individually each a "Product") to be free from defects in material and workmanship ("Defects") at the date of shipment. EXCEPT AS SET FORTH BELOW, NO OTHER WARRANTY, WHETHER EXPRESS OR IMPLIED, INCLUDING ANY WARRANTY OF MERCHANTABILITY OR FITNESS FOR A PARTICULAR PURPOSE, SHALL EXIST IN CONNECTION WITH THE SALE OR USE OF SUCH PRODUCTS. TO THE EXTENT PERMITTED BY LAW, ANY AND ALL IMPLIED WARRANTIES ARE EXCLUDED. All claims under this warranty must be made in writing and delivered to Powerex, or such claim shall be barred. Upon timely receipt of a claim, Powerex shall inspect the Product claimed to have a Defect, and Powerex shall repair, or, at its option, replace, free of charge, any Product which it determines to have had a Defect at the time of shipment from Powerex; provided, however, that if circumstances are such as to preclude the remedying of Defect by repair or replacement, Powerex shall, upon return of the Product, refund to buyer any part of the purchase price of such Products paid to Powerex. Freight for returning Products to Powerex for inspection shall be paid by buyer. The warranties and remedies herein are the sole and exclusive remedy for any breach of warranty or for any other claim based on any Defect, or non-performance of the Products, whether based upon contract, warranty or negligence.

(b) Initial Period of Warranty – Parts and Labor. Powerex warrants and represents all Products shall be free from Defects for the first twelve (12) months from the date of shipment by Powerex, or five thousand (5,000) hours of use, whichever occurs first. During such warranty period, Powerex shall be fully liable for all Defects in the Products (the "Product Defects"), i.e., all costs of repair or replacement, which may include "in and out" charges, so long as the Products are located in the continental United States, and the Products are reasonably located and accessible by service personnel for removal. "In and out" charges include the costs of removing a Product from buyer's equipment for repair or replacement.

(c) Additional Period of Warranty – Parts Only (No Labor). In addition to the above, Powerex warrants each Powerex branded Compressor Air-End, and Vacuum Pump shall be free of Defects for a period of thirty-six months from the date of shipment of Product, or 10,000 hours of use, whichever occurs first. Supplier's repair or replacement of any Product shall not extend the period of any warranty of any Product. This warranty applies to the exchange of part(s) found to be defective by an Authorized Powerex Service Center only.

(d) Coverage. The above mentioned warranty applies to Powerex manufactured units or systems only.

(e) Exceptions. Notwithstanding anything to the contrary herein, Powerex shall have no warranty obligations with respect to Products:

- (i) that have not been installed in accordance with Powerex's written specifications and instructions;
- (ii) that have not been maintained in accordance with Powerex's written instructions;
- (iii) that have been materially modified without the prior written approval of Powerex; or
- (iv) that experience failures resulting from operation, either intentional or otherwise, in excess of rated capacities or in an otherwise improper manner.

(f) The warranty provided herein shall not apply to: (i) any defects arising from corrosion, abrasion, use of insoluble lubricants, or negligent attendance to or faulty operation of the Products; (ii) ordinary wear and tear of the Products; or (iii) defects arising from abnormal conditions of temperature, dirt or corrosive matter; (iv) any OEM component which is shipped by Powerex with the original manufacturer's warranty, which shall be the sole applicable warranty for such component.

Limitation of Liability. TO THE EXTENT ALLOWABLE UNDER APPLICABLE LAW, NOTWITHSTANDING ANYTHING TO THE CONTRARY HEREIN, UNDER NO CIRCUMSTANCES SHALL POWEREX BE LIABLE FOR ANY INCIDENTAL, CONSEQUENTIAL, PUNITIVE, SPECULATIVE OR INDIRECT LOSSES OR DAMAGES WHATSOEVER ARISING OUT OF OR IN ANY WAY RELATED TO ANY OF THE PRODUCTS OR GOODS SOLD OR AGREED TO BE SOLD BY POWEREX TO BUYER. TO THE EXTENT ALLOWABLE UNDER APPLICABLE LAW, POWEREX'S LIABILITY IN ALL EVENTS IS LIMITED TO, AND SHALL NOT EXCEED, THE PURCHASE PRICE PAID.

Warranty Disclaimer. Powerex has made a diligent effort to illustrate and describe the Products in this literature accurately; however, such illustrations and descriptions are for the sole purpose of identification, and do not express or imply a warranty that the Products are merchantable, or fit for a particular purpose, or that the Products will necessarily conform to the illustrations or descriptions.

Product Suitability. Many jurisdictions have codes and regulations governing sales, construction, installation, and/or use of Products for certain purposes, which may vary from those in neighboring areas. While Powerex attempts to assure that its Products comply with such codes, it cannot guarantee compliance, and cannot be responsible for how the product is installed or used. Before purchase and use of a Product, please review the Product applications, and national and local codes and regulations, and be sure that the Product, installation, and use will comply with them.

Claims. Claims pertaining to the Products, with the exception of warranty claims, must be filed with Powerex within 6 months of the invoice date, or they will not be honored. Prices, discounts, and terms are subject to change without notice or as stipulated in specific Product quotations. All agreements are contingent upon strikes, accidents, or other causes beyond our control. All shipments are carefully inspected and counted before leaving the factory. Please inspect carefully any receipt of Products noting any discrepancy or damage on the carrier's freight bill at the time of delivery. Discrepancies or damage which obviously occurred in transit are the carrier's responsibility and related claims should be made promptly directly to the carrier. Returned Products will not be accepted without prior written authorization by Powerex and deductions from invoices for shortage or damage claims will not be allowed. **UNLESS OTHERWISE AGREED TO IN WRITING, THESE TERMS AND CONDITIONS WILL CONTROL IN ANY TRANSACTION WITH POWEREX** any different or conflicting terms as may appear on any order form now or later submitted by the buyer. All orders are subject to acceptance by Powerex.