



## Scroll Enclosure Air Compressor 30 HP to 40 HP

Please read and save these instructions. Read carefully before attempting to assemble, install, operate or maintain the product described. Protect yourself and others by observing all safety information. Failure to comply with instructions could result in personal injury and/or property damage! Retain instructions for future reference.

### DESCRIPTION

#### GENERAL

Powerex Scroll Enclosure Air Compressors are designed to supply continuous oil-free air by using the most advanced scroll technology. These turn-key packages are extremely quiet and offer electronic control that will reduce electrical power consumption.

The Powerex Oil-less Rotary Scroll Air Compressor has advanced scroll compressor technology through the development of a completely oil-less unit. The Powerex Scroll Compressor offers a dynamically balanced air end which insures vibration-free operation. The rotary design permits a continuous 100% duty cycle. No oil separation, oil filtration, or inlet valves are required on the Powerex Scroll unit. The compressor is virtually maintenance free.

The Powerex Oil-less Rotary Scroll Air Compressor is based on the theory of scroll compression. A scroll is a free standing, intricate spiral bounded on one side by a solid, flat plane or base. A scroll set, the basic compression element of a scroll compressor, is made up of two identical spirals which form right and left hand parts. One of these scroll components is indexed or phased 180° with respect to the other so the scrolls can mesh. Crescent-shaped gas pockets are formed and bounded by the spirals and the base plate of both scrolls. As the moving scroll is orbited around the fixed scroll, the pockets formed by the meshed scrolls follow the spiral toward the center and diminish in size. The moving scroll is prevented from rotating during this process so the 180° phase relationship of the scrolls is maintained. The compressor's inlet is at the outer boundary of the scrolls. The entering gas is trapped in two completely opposite gas pockets and compressed as the pockets move toward the center. The compressed gas is discharged through the outlet at the center of the fixed scroll so no valves are needed.

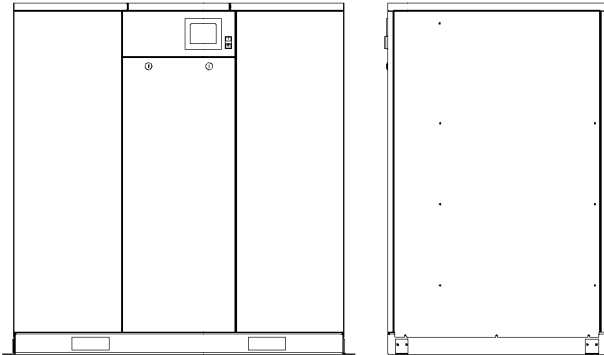

### SPECIFICATIONS

Product	SE Series Enclosed Scroll Air Compressor
Performance Specifications	See page 2
Lubrication	Grease-filled Bearing
Operating Voltages	3Ø - 208-230/460/575 Volts, 60 Hz; 380 volts, 50 Hz
Compression Cycle	Scroll
Motor Overload Protection	Motor Protector/Circuit Breaker
Pressure Settings	Cut in: 90 psig Cut out: 116 psig Cut in: 116 psig Cut out: 145 psig (High Pressure Units)
Overpressure Protection	Safety Valve Factory Set and Sealed
Outlet Air Connections	See page 2
Tank Sizes	See Page 6, Chart 3
Drive	3V Belt
Control Panel	UL508A Listed

Table of Contents			
Specifications	Pg 1-2	Troubleshooting	Pg 14
Safety Guidelines	Pg 2-3	Electrical	Pg 15-17
Installation	Pg 3-7	Parts List	Pg 18-19
Operation	Pg 7-11	Warranty	Pg 20
Maintenance	Pg 12-13		

Powerex - 150 Production Drive - Harrison, Ohio 45030 - USA  
1-888-769-7979 - www.powerexinc.com

# 30 HP– 40 HP Scroll Enclosure Air Compressors

## SPECIFICATION CHART

Model	HP	Max Pressure PSIG	SCFM @ Max Pressure	Voltage	Noise Level dB(A)	Discharge Connection	LxWxH (inches)	Unit Weight (lbs.)	Discharge Air Approach Temp
SEH3007	30	116	91.2	208/230/380/460/575	59	1 Inch	38 x 58 x 62	1640	67°F
SEH3007HP*	30	145	75	208/230/380/460/575	59	1 Inch	38 x 58 x 62	1640	80°F
SEO4007	40	116	121.6	208/230/380/460/575	60	1 Inch	38 x 58 x 62	2000	67°F
SEO4007HP*	40	145	100	208/230/380/460/575	60	1 Inch	38 x 58 x 62	2000	80°F

\*HP indicates high pressure model.

## SAFETY GUIDELINES

This manual contains information that is very important to know and understand. This information is provided for SAFETY and to PREVENT EQUIPMENT PROBLEMS. To help recognize this information, observe the following symbols. MAKE SURE EVERYONE OPERATING OR SERVICING THE COMPRESSOR READS AND UNDERSTANDS ALL THE INFORMATION PROVIDED.

**⚠ DANGER** Danger indicates and imminently hazardous situation which, if not avoided, WILL result in death or injury.

**⚠ WARNING** Warning indicates a potentially hazardous situation which, if not avoided, COULD result in death or serious injury.

**⚠ CAUTION** Caution indicates a potentially minor or moderate injury.

**NOTICE** Notice indicates important information, that if not followed, may cause damage to equipment.

## GENERAL SAFETY INFORMATION

Since the air compressor makes up a high pressure system, the following safety precautions must be observed at all times.

1. Read all manuals included with this product carefully. Be thoroughly familiar with the controls and the proper use of the equipment.
2. Follow all local electrical and safety codes as well as in the United States, the National Electrical Codes (NEC) and Occupational Safety and Health Act (OSHA).
3. Only persons well acquainted with these rules of safe operation should be allowed to use the compressor.
4. Keep visitors away and NEVER allow children in the work area.



5. Wear safety glasses and use hearing protection when operating the unit.
6. Do not stand on or use the unit as a handhold.
7. Before each use, inspect compressed air system and electrical components for signs of damage, deterioration, weakness or leakage. Repair or replace defective items before using.
8. Check all fasteners at frequent intervals for proper tightness.

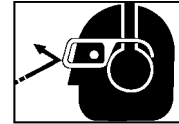

**⚠ WARNING** Motors, electrical equipment and controls can cause electrical arcs that will ignite a flammable gas or vapor. Never operate or repair in or near a flammable gas or vapor. Never store flammable liquids or gases in the vicinity of the unit.



**⚠ WARNING** Never operate compressor pump without a protective guard. This unit can start automatically without warning. Personal injury or property damage could occur from contact with moving parts.

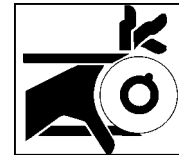

**⚠ DANGER** BREATHABLE AIR WARNING

This unit is NOT equipped and should NOT be used “as is” to supply breathing quality air. For any application of air for human consumption, you must fit the air compressor with suitable in-line safety and alarm equipment. This additional equipment is necessary to properly filter and purify the air to meet minimal specifications for Grade D breathing as described in Compressed Gas Association Commodity Specification for Air, OSHA, ANSI and/or Canadian Standards Associations (CSA).

**DISCLAIMER OF WARRANTIES**  
 IN THE EVENT THE COMPRESSOR IS USED FOR THE PURPOSE OF BREATHING AIR APPLICATION AND PROPER IN-LINE SAFETY AND ALARM EQUIPMENT IS NOT SIMULTANEOUSLY USED, EXISTING WARRANTIES ARE VOID, AND POWEREX DISCLAIMS ANY LIABILITY WHATSOEVER FOR ANY LOSS, PERSONAL INJURY OR DAMAGE.

## 30 HP - 40 HP Scroll Enclosure Air Compressors

### GENERAL SAFETY CONT.

9. Do not wear loose clothing or jewelry that will get caught in the moving parts of the unit.

#### ⚠ CAUTION

Surface may be hot even if unit is stopped.



10. Keep fingers away from a running unit; fast moving and hot parts will cause injury and/or burns.
11. If the equipment should start to vibrate abnormally, STOP the unit and check immediately for the cause. Vibration is generally a warning of trouble.
12. To reduce fire hazard, keep unit exterior free of oil, solvent, or excessive grease.

#### ⚠ WARNING

An ASME code safety relief valve with a setting no higher than the tank maximum allowable working pressure **MUST** be installed in the air lines or in the tank of any compressor. The ASME safety valve must have sufficient flow and pressure ratings to protect the pressurized components from bursting.

13. Never attempt to adjust ASME safety valve on compressed air units. Keep safety valve free from paint and other accumulations.

#### ⚠ DANGER

Never attempt to repair or modify a tank! Welding, drilling or any other modification will weaken the tank resulting in damage from rupture or explosion. Always replace worn, cracked or damaged tanks.



#### NOTICE

Drain liquid from tank daily.

14. Tanks rust from moisture build-up, which weakens the tank. Make sure to drain tank regularly and inspect periodically for unsafe conditions such as rust formation and corrosion.
15. Fast moving air will stir up dust and debris which may be harmful. Release air slowly when draining moisture or depressurizing a compressor system.

### INSTALLATION

#### ⚠ WARNING

Disconnect, tag and lock out power source then release all pressure from the system before attempting to install, service, relocate or perform any maintenance.

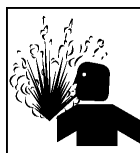

#### ⚠ CAUTION

Do not lift or move unit without appropriately rated equipment. Be sure the unit is securely attached to lifting device used. Do not lift unit by holding on to tubes or coolers. Do not use unit to lift other attached equipment.

#### ⚠ CAUTION

Never use the wood shipping skids for mounting the unit.

#### ⚠ CAUTION

Do not locate the air inlet near steam, paint spray, sandblast areas or any other source of contamination.

**NOTE:** If compressor system is installed in a hot, moist environment, supply compressor pump with clean, dry outside air. Pipe supply air in from external sources.

#### ⚠ WARNING

Failure to properly install a tank can lead to cracks at the welded joints and possible bursting or leakage.

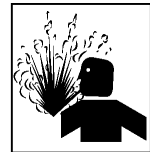

### UNPACKING

After unpacking the unit, inspect carefully for any damage that may have occurred during transit. Make sure to tighten fittings, bolts, etc., before putting unit into service.

#### ⚠ WARNING

Do not operate unit if damaged during shipping, handling or use. Damage may result in bursting and cause injury or property damage.

The compressor nameplate should be checked to see if the unit is the correct model and voltage as ordered.

### PRECAUTIONS DURING TRANSPORTATION AND MOVEMENT

#### TRANSPORTATION BY FORKLIFT

Use openings for forklift under both sides of the unit.

#### NOTICE

Avoid damaging the panel with tips of forklift.

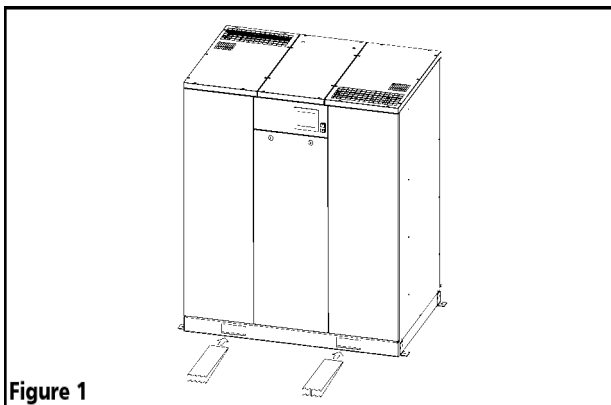

Figure 1

# 30 HP - 40 HP Scroll Enclosure Air Compressors

## INSTALLATION CONT.

### TRANSPORTATION BY CRANE

Use openings at bottom of the unit to lift up by cable, lifting straps etc. Make sure all lifting devices are rated for the maximum load.

**NOTICE** *Be sure to use pads in order to protect the panels.*

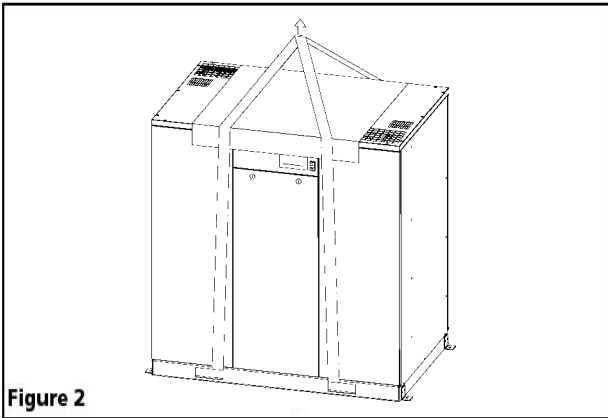

Figure 2

### INSTALLATION SITE

1. The scroll compressor must be located in a clean, well lit and well ventilated area. A contaminated area can clog the intake filter and / or intake metal mesh.

### INSTALLATION SITE Cont.

2. The area should be free of excessive dust, toxic or flammable gases, moisture and direct sunlight.
3. Never install the compressor where the ambient temperature is higher than 104°F or where humidity is high. High humidity will cause electrical short circuit and rusting of components.
4. Clearance must allow for safe, effective inspection and maintenance.

**NOTICE** *A minimum of 24 inches of clearance for sides, 40 inch clearance from the top is required.*

5. If necessary, use metal shims or leveling pads to level the compressor. Never use wood to shim the compressor.

### VENTILATION

1. If the scroll compressor is located in a totally enclosed room, an exhaust fan with access to outside air must be installed.
2. Never restrict the cooling fan exhaust air or the intake cooling air.
3. Vent the exhaust air outside to prevent the compressor from operating at high temperatures and shutting down.
4. Never locate the compressor where hot exhaust air from other heat generating units may be pulled into the unit.

### SUGGESTED VENTILATION SYSTEM

The temperature rise in the room must be kept to a maximum of 10 F. The BTU capacity of the vent system should be sized for the full operating HP rating of the compressor. Suggested fan capacity at 0 static pressure is shown below. If static pressure is higher, the fan capacity should be increased.

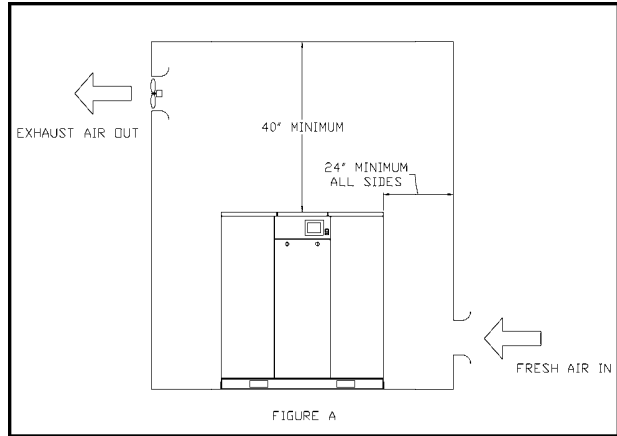

An exhaust duct may be installed to capture the warm air exiting the compressor enclosure. The opening of the exhaust duct should be about 6 inches larger on each side than the vent openings on the compressor top panel. The duct should not obstruct removal of the top panel for service. Leave between 8 and 12 inches of clearance.

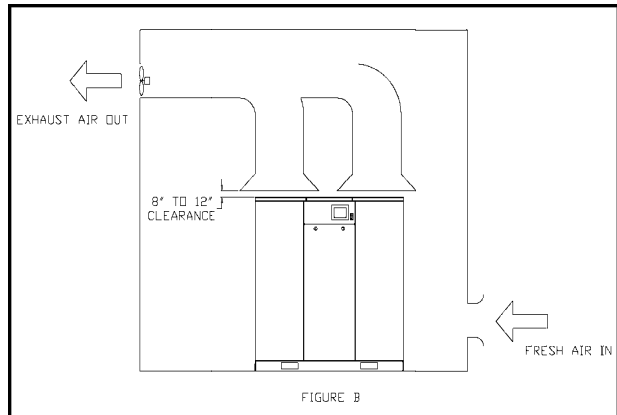

Model	Exhaust CFM Required	
	Figure A	Figure B
SEH3007	7770	2830
SEH3007HP	7770	2830
SEO4007	10595	3535
SEO4007HP	10595	3535

Chart 1

## INSTALLATION Cont'd

### WIRING

#### **⚠ WARNING**

*All wiring and electrical connections must be performed by a qualified electrician. Installations must be in accordance with local and national codes.*

#### **⚠ CAUTION**

*Overheating, short circuiting and fire damage will result from inadequate wiring.*

The Powerex Scroll Enclosure Air Compressor is completely factory wired and requires only a 3 phase supply circuit. A set of terminals is provided for connection of the supply conductors and ground conductor. See Figure 3 below for more detail.

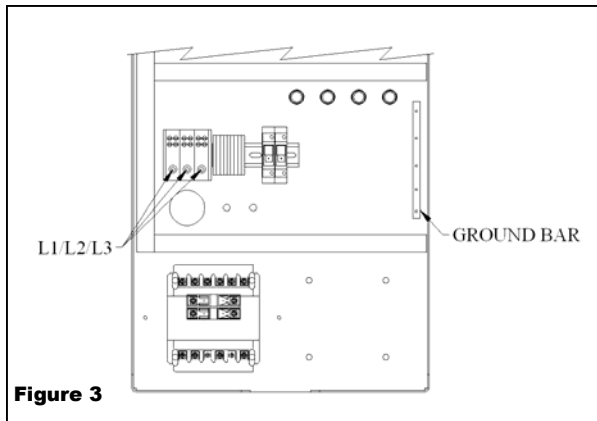

**Figure 3**

A 2 inch opening is provided for conduit or cord connection. See Figure 4 for opening location.

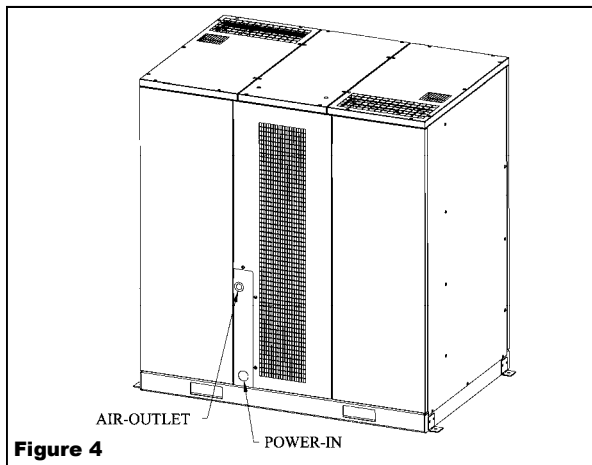

**Figure 4**

Wiring must be installed in accordance with National Electric Code and local codes and standards that have been set up covering electrical apparatus and wiring. Consult the codes and standards and observe local ordinances. Be certain that adequate wire sizes are used, and that:

1. Service is of adequate ampere rating.
2. The supply line has the same electrical characteristics (voltage cycles and phase) as the motor.
3. Ensure the line wire is the proper size and that no other equipment is operated from the same line. The chart gives the recommended wire sizes for horsepower of motor provided.

Recommended wire sizes may be larger than the minimum set up by local ordinances. If so, use the large size wire to prevent excessive line voltage drop.

Chart 2  
**MINIMUM WIRE SIZE  
USE 75°C COPPER WIRE**

HP	Three Phase			
	208V	230V	460V	575V
30	1 AWG	2 AWG	6 AWG	8 AWG
40	2/0 AWG	1/0 AWG	4 AWG	6 AWG

The additional wire cost is very small compared with the cost of repairing or replacing a motor electrically "starved" by the use of supply wires which are too small.

### GROUNDING

#### **⚠ DANGER**

*Improperly grounded electrical components are shock hazards. Make sure all the components are properly grounded to prevent death or serious injury.*



This product **must** be grounded. Grounding reduces the risk of electrical shock by providing an escape wire for the electrical current if short circuit occurs.

All electrical hook-ups must be performed by a qualified electrician. Installations must be in accordance with local and national electrical codes.

1. A service disconnect and fuses or a circuit breaker must be installed to supply electric power to this compressor. Make sure the circuit is sized to handle the full operating load as shown in the table.
2. Remove the front panel to access the wiring area.
3. Using appropriate strain relief and cable management techniques, connect the power cable to the power junction block and the ground wire to the ground bar. Consult your NEC and local codes for wire size.

## INSTALLATION Cont'd

### GENERAL FAULT DRY CONTACT CONNECTIONS

1. Turn the compressor off and lockout the power to the compressor per OSHA standards.
2. Remove the door panel from the scroll cabinet to access the operating panel.
3. Output wires should be connected between terminals 10 and 11. The dry contacts are normally closed; when there is a fault or loss of power to the system, the contacts open. The contact rating is as follows: 240VAC/2A or 30VDC/2A, maximum.
4. For larger load devices such as a horn or emergency light, a relay should be used.
5. The signal wires should be between 24 and 12 AWG and run through the grommet provided beneath the terminal blocks.
6. Replace the plastic cover of the operating panel. Replace the door panel to the scroll compressor cabinet.
7. Return the power to the compressor system.

### PIPING

**⚠WARNING**

*Never use plastic (PVC) pipe for compressed air. Serious injury or death could result.*

Any tube, pipe or hose connected to the unit must be able to withstand the temperature generated and retain the pressure. All pressurized components of the air system must have a pressure rating higher than or equal to the ASME safety valve setting. Incorrect selection and installation of any tube, pipe or hose could result in bursting and injury.

**⚠WARNING**

*Never install a shut-off valve between a compressor pump and the tank without an appropriate safety valve. Personal injury and/or equipment damage may occur. Never use reducers in discharge piping.*

The Powerex Scroll Enclosure Air Compressor has an ASME safety relief valve at the outlet pipe nipple connection point. When creating a permanently installed system to distribute compressed air, find the total length of the system and select pipe size from the chart. Bury underground lines below the frost line and avoid pockets where condensation can gather and freeze.

Apply air pressure to the piping installation and make sure all joints are free from leaks BEFORE underground lines are covered. Before putting the unit into service, find and repair all leaks in the piping, fittings and connections.

Select the size of the air receiver so that the combined volume of the air receiver and facility piping results in a long enough cycle time to keep any individual motor from starting more than once every 3.43 minutes. Selecting the widest possible spread between high and low system set point pressure along with the largest differential for each pump interval will reduce the starting frequency.

The table below shows the recommended tank size in gallons per model. Some conditions of air usage may require additional volume.

Differential*	SEH	SEO
Min	240	240
Standard	200	200
Max	120	120

**Chart 3**

\* Pressure setting selected on control panel

1. Make sure the piping is lined up without being strained or twisted when assembling the piping for the scroll compressor.
2. Appropriate expansion loops or bends should be installed at the compressor to avoid stresses caused by changes in hot and cold conditions.
3. Piping supports should be anchored separately from the compressor to reduce noise and vibration.
4. Never use any piping smaller than the compressor connection.
5. Use flexible hose to connect the outlet of the compressor to the piping so that the vibration of the compressor does not transfer to the piping.

### REMOTE INTAKE PIPING

Powerex compressor systems with pipe thread connectors on the intake filters are intended for installation with remote air intake. Piping for the remote intake system should be installed at the final operating site.

Under some conditions, the intake piping may facilitate the condensation of humidity in the intake air stream into liquid water.

**THE INTAKE FILTERS SUPPLIED BY POWEREX WILL NOT STOP INGESTION OF LIQUID WATER BY THE PUMPS. LIQUID WATER GOING INTO THE PUMPS WILL DAMAGE THE PUMPS AND VOID THE WARRANTY.**

**NOTICE**

*Always install drip legs with sufficient capacity to capture liquid water in the intake piping before the air filters. Drip legs must be sized with low enough air velocity to make sure they are effective at capturing liquid water in the intake air and must be maintained (drained) at frequent intervals to make sure they remain effective.*

## INSTALLATION Cont'd

### SAFETY VALVES

Safety Valves must be installed on every receiver. The flow capacity of a safety valve should be equal to or greater than the capacity of the compressor.

1. The pressure setting of the safety valve must not be greater than the maximum working pressure of the air receiver.
2. Safety valves should be placed ahead of any possible blockage point in the system, i.e. shutoff valve.
3. Avoid connecting the safety valve with any tubing or piping.
4. Manually operate the safety valve every six months to avoid sticking or freezing.

### CHECK VALVES

Do not install a check valve between the compressor and the air receiver or facility piping. If a check valve is installed, the compressor pressure sensor will see rapid pressure drops and cause short cycling of the motors and other control problems.

### ISOLATION VALVES

An isolation valve should be installed between the compressor and the air receiver to facilitate maintenance. Make sure the valve is open when operating the compressor. A second isolation valve should be installed between the air receiver and the facility piping.

### CONTROL PANEL - DISPLAY AND INPUT

The Powerex scroll enclosure air compressor has a power control switch and a touch screen or HMI panel on the front to allow operation and monitoring of the unit. See Controls section for details on operating the unit using the touch screen.

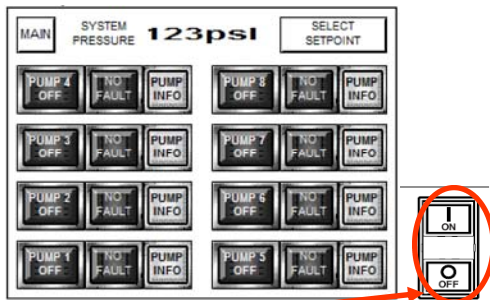

The switch beside the screen controls power to the motor starters. When the system is energized the HMI screen will be lit and the control screen is active, but the motors will not run until the ON button is pushed. When ON is pushed, the center section of the switch will illuminate, enabling the PLC control of the system, and will remain lit until the OFF button is pushed. The OFF button on the switch may be used to stop the compressors at any time. The switch does not turn off power to the panel so be sure to lock out the power source before opening the panel for service.

**NOTE:** The "Jog" function on the screen overrides the ON switch. The motors will operate if the Jog button is continually depressed. To reach "JOG" press the SYSTEM STATUS button, then press PUMP INFO for the pump module you want to jog.

The PUMP INFO screen is shown below. Press the > arrow button to jog pumps.

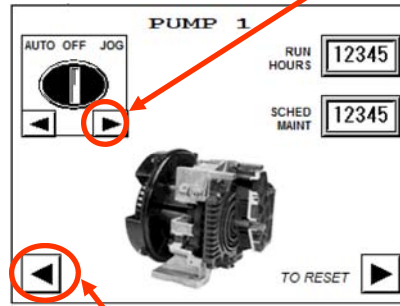

Use the < arrow button to go back and select the next pump.

If the SYSTEM STATUS screen is not visible, go back to the MAIN screen and select SYSTEM STATUS. (see below)

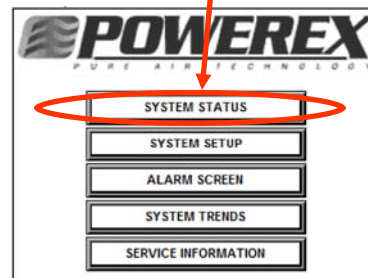

## OPERATION

### BEFORE START UP

1. Make sure all safety warnings, labels and instructions have been read and understood before continuing.
2. Remove any shipping materials, brackets, etc.
3. Confirm that the electric power source and ground have been firmly connected.
4. Check the belts for tightness.
5. Be sure all pressure connections are tight.
6. Check to be certain all safety relief valves etc., are the proper size.
7. Securely mount all panels and guards.
8. Check that all fuses, circuit breakers etc., are the proper size.
9. Make sure the inlet filter is properly installed.
10. Secure the area in front of the compressor to prevent unauthorized access during this check. Remove the front-left and right-rear access panels so that the motor pulley on each set is visible.

# 30HP - 40HP Scroll Enclosure Air Compressors

## OPERATION Cont'd

### NOTICE

Check motor rotation before operating the unit.

Turn power on the unit and exercising extreme caution, use the HMI display/input screen to jog each motor. (To reach the JOG function, select SYSTEM STATUS from the MAIN screen, then select PUMP INFO for each installed pump/motor set). Powerex wires the controls so all motors rotate in the same direction. Correct rotation is CW looking at the pulley from the motor side. If all or any of the motors rotate incorrectly, lock out the power, correct the input wiring and recheck. If any motor wiring is ever disturbed or modified, recheck each motor for proper rotation direction. Restore the access panels before operating the unit.

### INITIAL START UP AND SET UP OF THE CONTROL

The control is programmed at the factory and default settings are installed. To access certain control functions you will need to enter a seven digit authorization code. You may select your own code. We recommend using the last seven digits of the unit serial number.

To enter the code, from the SYSTEM STATUS screen touch SELECT SETPOINT.



Go to PG 2 of the SELECT SETPOINT screen.

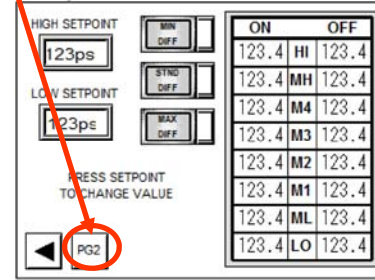

The second page of the SETUP screen will appear.

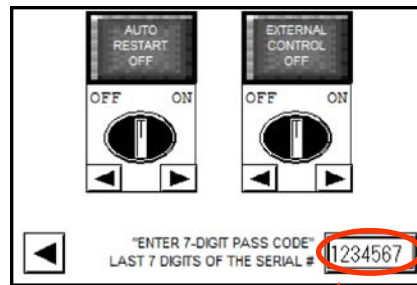

Touch the rectangle to enter the Authorization Code and enter seven digits using the keypad that appears. Powerex suggests using the last seven digits of the serial number. You may now return to the SYSTEM STATUS screen.

### START-UP AND OPERATION

1. Follow all the procedures under “Before start-up” before attempting operation of the compressor.
2. Switch on the electric source.
3. Verify the display screen is lit.
4. If an isolation valve is installed between the compressor unit and the air receiver, make sure it is open. Close the isolation valve between the air receiver and the facility piping.

The sequence is an example of operation of SEO4007.

SEH3007 operate 6 air ends.

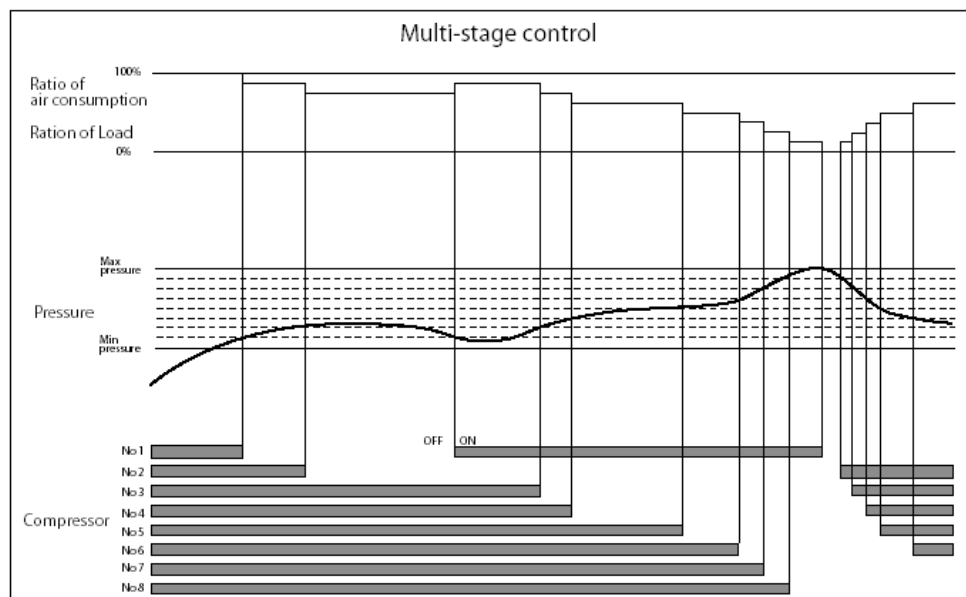

Chart 4



**OPERATION Cont'd**

5. Pushing the ON button beside the touch screen will allow the unit to start and operate automatically. Pushing the OFF button will stop the motors, but the HMI screen will remain active.
6. If the pressure does not rise, turn the unit off, the unit is running backwards. Have a qualified electrician switch the breaker OFF and exchange two out of the three phases of electrical source. If pressure is rising, allow the compressor unit to run. Each compressor motor will automatically turn off as the pressure rises and the maximum operating pressure is reached. Pressure settings may be adjusted as described below.
7. Open the isolation valve between the air receiver and the facility piping. The compressor will start and stop each pump as needed to maintain the pressure between the high and low set points.
8. After a few hours and again after a few days, check the display screen to see if the ALARM screen has appeared. If a HIGH TEMPERATURE or MOTOR OVERLOAD condition occurs, the alarm screen will appear and the affected pump-motor will be taken out of service. If the chosen settings are causing the motors to start too frequently, the ALARM screen will appear and the MOTOR WARNING indicator will illuminate. Motor warning will not take the motor out of service, but the user should take action to prevent motor overload and damage. To reduce motor starting frequency, adjust the set points to a wider range between High and Low and possibly increase the differential. If starting is still too frequent, a larger or additional air receiver will be needed.

**SHUT-DOWN**

1. Stop the compressor by pushing the OFF button.  
**NOTE:** If the compressor rotates in reverse for more than five seconds, the check valve needs to be cleaned or replaced.
2. Switch the breaker OFF if the compressor is not to be used for a long period of time.

**STOPPING THE COMPRESSOR DURING EMERGENCY OPERATION**

Stop the compressor by pushing the OFF button or by turning the power off at the main disconnect panel.

**MULTI-STAGE CONTROL**

As this compressor uses plural air ends, it employs multi-stage control. It can start and stop each air end according to pressure and air consumption, automatically select the number of air ends in accordance with air consumption and achieve optimum and uniform operation at all times as well as energy-saving and labor-saving operation.

1. Multi-stage control - Among air ends which are operating under group control, it stops the air end which has been operating for a longer time and restarts the air end whose operating time has been shorter, thus resulting in equalization of operating time of each air end and operation with a min.

- quantity of air ends in accordance with air consumption and energy-saving operation by eliminating waste of electricity. Chart 4 shows the relationship between pressure and the quantity of air ends operating for an SEO model. The same concept is applied to 6 air ends for an SEH.
2. Automatic Alteration: When air demand allows one or more air ends to remain idle, the control will automatically shift operation to equalize usage after 10 minutes. If air demand increases and pressure drops, the control will energize additional air ends as needed, starting the one with the longest off time first. The control will also de-energize air ends as pressure rises.
  3. The control allows the user to adjust the pressure settings. To minimize power consumption, the user should select the lowest maximum pressure that is suitable for the operations being performed. The smallest gap between minimum and maximum pressure that avoids too frequent motor starting should also be selected.
  4. The control will automatically prevent multiple motors from starting simultaneously by inserting a three second delay.

**OPERATING PANEL & SETTINGS**

The Scroll Enclosure Air Compressor is controlled by a PLC programmed at the Powerex factory. The operating status is displayed on the HMI- touch screen panel on the front of the compressor unit. The touch screen allows the user to select operating parameters within predetermined limits set at the factory. The touch screen also allows the user to change the display to get more information about the operation of the individual compressor modules and to take action based on alarms and warnings. This enclosed scroll system utilizes a PLC for alternation and will change the pump sequence (Lead, Lag1, Lag2 etc) after every start or after 10-minutes, whichever ever happens first. The HMI offers a MIN and MAX system setpoint and three calculated pressure differential settings. (Standard, Min and Max)

The factory default settings for HIGH and LOW Operating Pressures are:	
Standard Models	90-116 PSIG
High Pressure Models	119-145 PSIG
Differential setting default is STANDARD	

Limits to difference between HIGH and LOW setpoints are:	
Maximum Differential	50 PSIG
Minimum Differential	16 PSIG

## 30HP - 40HP Scroll Enclosure Air Compressors

### OPERATION Cont'd

The control automatically divides the range between HIGH and LOW Operating Pressure into equal operating intervals. The differential for the operating intervals may be adjusted by selecting STANDARD, MIN or MAX on the set up screen.

In **STANDARD**, the differential will be automatically set to have a slight overlap between the individual pump intervals. Each interval will be 135% of the possible minimum value.

In **MIN**, the differential will be automatically set to divide the available range into equal intervals with no overlap. The selection will result in the most frequent starting of the electric motors for a given Operating Pressure range.

**NOTE:** more frequent motor starting can lead to reduced motor life. Exceeding 17.5 starts per hour will cause a warning display.

In **MAX**, the differential will be automatically set to increase the overlap as compared to the Standard setting. Each interval will be 235% of the possible minimum interval. Select this mode to minimize the frequency of motor starts. Motor start frequency can be reduced by using larger air receiver tanks, selecting a wider range between HIGH and LOW Operating Pressure and by selecting the widest differential.

To minimize power consumption, select the lowest possible HIGH operating pressure and the smallest differential that avoids exceeding the motor start frequency limit.

### PERFORMING PRESSURE ADJUSTMENTS



The above display is the SYSTEM STATUS screen. (For the SEH model, only six sets of buttons/indicators will be shown).

To adjust pressure settings, touch the SELECT SETPOINT button. The screen will change to this display:

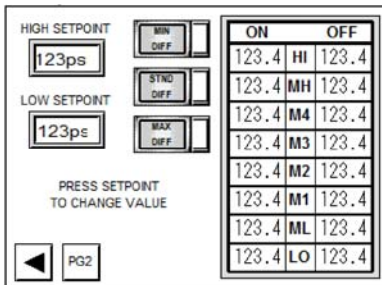

Touch the screen at either the HIGH SETPOINT or LOW SETPOINT button/indicator. A key pad display will be shown. Enter the desired pressure setting using the key pad and touch ENT.

CLR is clear, use it to backspace one digit.

CAN or Cancel, voids the whole input, use it to start over.

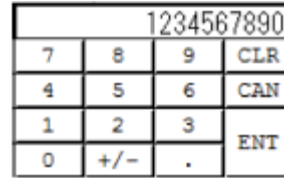

Pressure settings must be entered as whole numbers, no decimal or fractions. The individual intervals will be calculated and shown in the display boxes on the right side of the setting screen. If number are entered that are out of the allowed range, the input will be scaled back to the range limit.

### ALARM SIGNALS

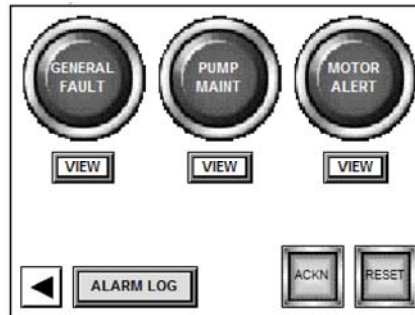

The PLC control for the scroll enclosure compressor will display the ALARM screen and activate the GENERAL FAULT indicator on the alarm screen display if either of the two conditions occurs:

1. High temperature at the sensor located at the after cooler inlet. Each compressor module has its own sensor. A high temperature condition will result in the power to that motor being shut off. The GENERAL FAULT alarm display will stay on and the circuit will stay off even after the sensor cools, and can only be restored when the alarm is cleared by a user. If a high temperature condition occurs, the reason should be determined and corrected before restarting the circuit as un-repairable damage to the scroll pump may result from operation with repeated high temperature alarms.
2. Motor Overload, if the current to the motor exceeds the setting of the adjustable motor protector, the contactor associated with that motor is de-energized, and that motor will not run. The alarm display and condition is maintained until the alarm is cleared and the motor protector reset. The circuit will be restarted as needed. If a motor overload occurs,

### OPERATION Cont'd

the root cause should be determined and corrected or motor damage may result.

The user can activate the acknowledge function (button labeled ACKN) to allow the display to go back to SYSTEM STATUS or any other screen. Touch the VIEW button to advance to a screen showing which pump-motor assembly is in fault and for what reason. The fault will display and the affected pump-motor will be disabled until the RESET button is pushed.

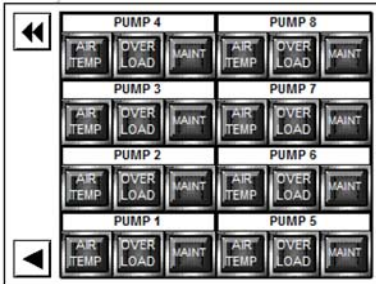

The PUMP MAINT indicator will activate when the running hours of any pump accumulates to a required maintenance interval. The system is designed for multiple pumps to accumulate hours evenly and for maintenance intervals to be approached simultaneously. To prevent nuisance PUMP MAINT indications, all applicable maintenance counters should be reset after the required maintenance actions are performed. Use ACKN to allow the STATUS screen or other screens to be displayed. Touch the VIEW button to advance to the next screen. Consult the maintenance chart 6 and scroll air compressor manual for details of what maintenance needs to be performed. To reset the PUMP MAINT indicator for an individual pump, open the PUMP INFO screen for that pump, hit the RESET button and use the keypad display to enter the authorization code when prompted.

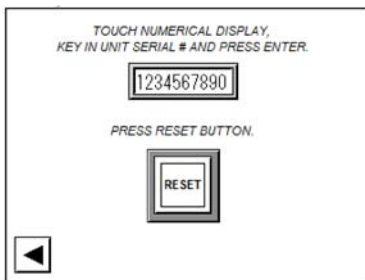

Motor Warning: The control also tracks how many times per hour an individual motor is called on to start. If the starts per hour exceed 17.5, there is an increased risk of motor damage. The warning is displayed, but the system is not shut down. The user can select a wider operating pressure differential to reduce the starts per hour or install a larger air receiver. The ACKN button, which will have to be pressed for each motor in alert, allows the display to be shifted back to SYSTEM STATUS or any other screen before the warning automati-

cally resets itself at the end of the hour. The RESET button will not clear the warning.

### ALARM LOG

A record of all alarm or warning events is kept in the alarm log. Reset status is tracked as well. The alarm log is maintained as long as the unit is powered and for up to three days after power is removed from the control.

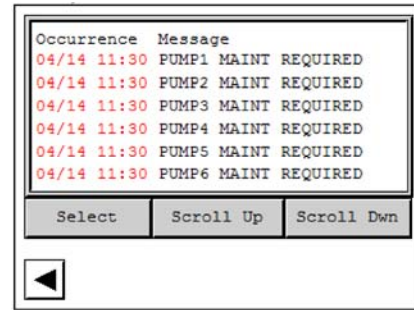

### SYSTEM TRENDS

The following additional information is available by selecting the SYSTEM TRENDS from the MAIN screen:

The control tracks the amount of time the pumps are in use and compares that to the available time. The ratio is displayed. The LOAD FACTOR is displayed for the most recent 24 hour period.

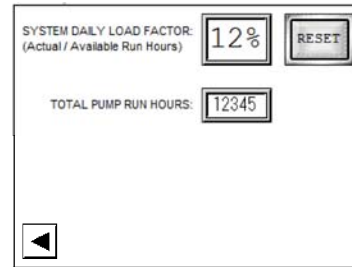

### AUTOMATIC RESTART

When power is applied to the Powerex scroll enclosure compressor control, the display will illuminate and go to the MAIN screen. Settings will be retained from the last time the system had power. The motors will not energize until the ON button is pushed on the control switch beside the display. (Only the JOG function will override the ON button). In the event of a loss of power, the user must push the ON button to restore the compressors to operation. If automatic restart is desired, go to the SYSTEM SETUP screen PG2 and press the > arrow on the left selector switch. To disable, press the < arrow.

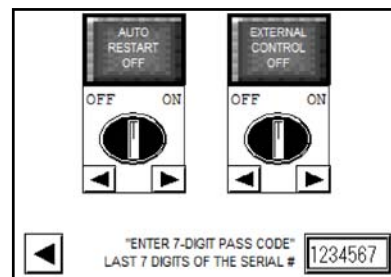



## 30HP - 40HP Scroll Enclosure Air Compressors

### MAINTENANCE

#### LOCKING OUT POTENTIAL TO PERFORM MAINTENANCE PROCEDURES

The enclosure is equipped with the components to mechanically and electrically lock out both stacks of pump/motor assemblies. Proper OSHA lockout/tagout procedures should be abided by at all times. Electric potential to each motor can be locked out using the lockable motor protectors. (See Figure 5) Electric potential to the ventilation fans and temperature switches can be locked out using the 4 circuit breakers provided on the control panel. (See Figure 6) Circuit breakers #1 and #3 are associated with the left bank of compressors while #2 and #4 are associated with the right bank. Mechanical potential can be locked out using the lockable ball valves located behind the control panel and are accessible by removing the back center intake panel. (See Figure 7) After closing either ball valve, bleed the remaining line pressure by pulling the provided safety relief's ring to remove all potential within a bank of compressors.

#### ADJUSTING BELT TENSION

**⚠ DANGER**

*Moving Parts! Lock out power before servicing unit!*

After the first 200 to 500 running hours or at any time chirping is heard on start up, check the belt tension. If tension is below 25 pounds on any belt, increase the center distance using the motor slide base so that belt tension is 45 to 50 pounds. The motor slide base details are shown below. If installing new belts see the procedure below:

#### NEW BELT INSTALLATION PROCEDURE

1. Loosen the two slide bolts near the motor pulley and the two slide bolts on the front edge of the base. Keep enough torque on them to take up any slack between the slider and the main base, but enough slack to allow the slider to move.
2. Tighten the belt adjustment bolt using a torque wrench to 45 inch pounds. This will bring the belts to the proper tension.
3. Tighten the slider bolts, the two on the front edge of the base, then the two slider bolts closest to the motor pulley so the belt tension is 45 to 50 pounds.

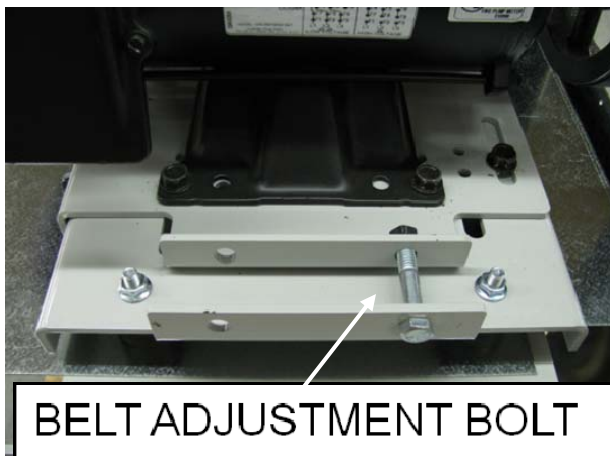

**HOLE FOR LOCK-OUT**

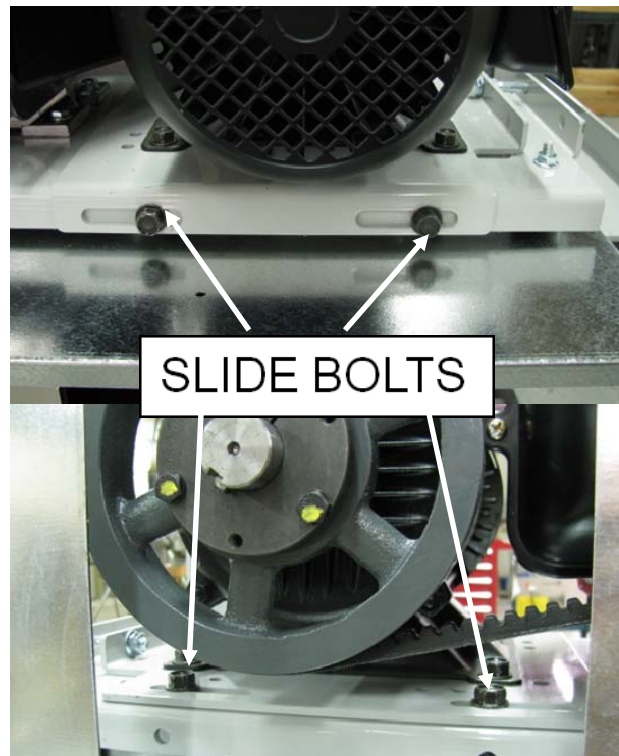

## 30HP - 40HP Scroll Enclosure Air Compressors

### MAINTANANCE SCHEDULE (Chart 6)

Item	Action Needed	Operating Hours					Remarks
		500	2500	5000	10,000	20,000	
Intake Filter	Inspect, Replace	●	▲				Every 2500 hours or less
Ventilation Screen	Clean	●					Every 500 hours or less
Air End/Blower Fan	Clean			●			Every 5000 hours or less
Fan Duct	Clean			●			Every 5000 hours or less
Compressor Fins	Clean		●				Every 2500 hours or less
Compressor	Grease				▲	Replace Pump	Use genuine Powerex grease (every 5000 hours for High Pressure Models)
Tip Seal	Replace				▲		(every 5000 hours for High Pressure Models)
Dust Seal	Inspect, Replace				▲		(every 5000 hours for High Pressure Models)
V-belt	Inspect, Replace	*	●	▲	▲		*Readjust
Pressure Sensor	Confirm Operation				●		Check touchscreen for pressure rise and fall
Magnetic Starter	Inspect				●		Replace if contact points are deteriorated/excessive arching
Check Valve	Inspect	●			▲		Confirm operation by watching pump and motor shut off and stop turning
Safety Valve	Confirm Operation						Every 500 hours or less. Pull ring to make sure not stuck or plugged.
Ventilation Fan	Inspect		●				Confirm ventilation air is exiting cabinet
Motor Pulley	Inspect Groove/ Make sure tight on shaft				●		Replace if abnormal wear is detected
Motor	Inspect				●	●	Replace if abnormal noise is detected./ Make sure electrical
Intake Hose	Inspect		●				Replace if damaged or deteriorating
Braided Hose	Inspect, Replace		●				Make sure there are no leaks
Aftercooler	Clean outside			●			Every 5000 hours or less
Operating Panel	Inspect monitor daily						Verify pressure/Check for alarm notification
Piping	Inspect for leaks		●				Every 2500 hours or less

- Inspect
- ▲ Replace

#### NOTES:

1. Inspect and perform maintenance periodically according to the maintenance schedule.
2. The maintenance schedule relates to the normal operating conditions. If the circumstances and load condition are adverse, shorten the cycle time and perform maintenance accordingly.
3. \*Marked "Readjust" means the tension of the V-belt should be adjusted during the initial stage and inspected every 2,500 hours afterwards.

## 30HP - 40HP Scroll Enclosure Air Compressors

### TROUBLESHOOTING GUIDE (Chart 7)

	Problem	Possible Cause	Corrective Action
Compressor does not operate	No Display on the Operating Panel	<ol style="list-style-type: none"> <li>1. The electric source is not turned on</li> <li>2. Transformer primary or secondary fuse open</li> <li>3. Electric source is not correctly connected</li> <li>4. Failure of display or PLC</li> </ol>	<ol style="list-style-type: none"> <li>1. Turn on electric source</li> <li>2. Replace</li> <li>3. Connect correctly</li> <li>4. Inspect, repair or replace</li> </ol>
	It does not operate despite displays	<ol style="list-style-type: none"> <li>1. Failure or wiring failure of magnetic starter</li> <li>2. Motor failure</li> <li>3. Low voltage</li> </ol>	<ol style="list-style-type: none"> <li>1. Inspect, repair or replace</li> <li>2. Inspect, repair or replace</li> <li>3. Check electric source capacity and the size of electric source cable and change to proper one</li> </ol>
	Alarm Screen Active	<ol style="list-style-type: none"> <li>1. High temperature condition</li> <li>2. Motor Overload condition</li> <li>3. High temperature indicated but unit is cool, has never been hot</li> </ol>	<ol style="list-style-type: none"> <li>1. Allow to cool and reset, determine cause</li> <li>2. Reset motor overload, reset alarm and determine root cause of overload</li> <li>3. A temperature switch may be disconnected or defective, check wiring</li> </ol>
Compressor starts but then stops	Alarm Screen High Temperature	<ol style="list-style-type: none"> <li>1. High ambient temperature or bad ventilation</li> <li>2. Clogging of aftercooler fins or intake wire screen</li> <li>3. Failure of ventilating fan</li> <li>4. Damage to intake hose</li> <li>5. Cooling passage of air end clogged</li> <li>6. High exhaust pressure</li> <li>7. Circuit breakers are open</li> </ol>	<ol style="list-style-type: none"> <li>1. Improve installation environment &amp; ventilation</li> <li>2. Clean</li> <li>3. Replace</li> <li>4. Replace</li> <li>5. Inspect and clean</li> <li>6. Inspect- control malfunction likely</li> <li>7. Inspect cause and close</li> </ol>
	Alarm Screen Motor Overload	<ol style="list-style-type: none"> <li>1. Low voltage</li> <li>2. Motor Failure</li> <li>3. Air end failure</li> <li>4. Loosened wiring screw</li> <li>5. High exhaust pressure</li> <li>6. Failure of thermal overload</li> </ol>	<ol style="list-style-type: none"> <li>1. Check electric source capacity, size of electric source cable and change to proper one</li> <li>2. Inspect, repair or replace</li> <li>3. Inspect, repair or replace</li> <li>4. Tighten</li> <li>5. Inspect - control failure likely</li> <li>6. Replace</li> </ol>
	Exhaust pressure does not increase	<ol style="list-style-type: none"> <li>1. Air leaks from exhaust piping</li> <li>2. Air-end rotates backward</li> <li>3. Wrong pressure setting</li> <li>4. Clogged intake filter</li> </ol>	<ol style="list-style-type: none"> <li>1. Inspect, repair</li> <li>2. Change phases</li> <li>3. Readjust</li> <li>4. Clean or replace</li> </ol>
	Safety valve activates	<ol style="list-style-type: none"> <li>1. Failure of safety valve</li> <li>2. Failure of pressure setting</li> </ol>	<ol style="list-style-type: none"> <li>1. Replace</li> <li>2. Inspect - control failure likely</li> </ol>
	Abnormal sound	<ol style="list-style-type: none"> <li>1. Air-end rotates backward</li> <li>2. Air end failure</li> <li>3. Belt slips</li> <li>4. Motor failure</li> <li>5. Cooling fan contacting frame</li> <li>6. Loosened bolts</li> </ol>	<ol style="list-style-type: none"> <li>1. Change phases</li> <li>2. Inspect, repair or replace</li> <li>3. Check tension and readjust</li> <li>4. Inspect, repair or replace</li> <li>5. Inspect and repair</li> <li>6. Inspect and tighten</li> </ol>

**BRANCH CIRCUIT PROTECTION TABLE (Chart 8)**

<b>(A) Load Specifications</b>					<b>(B) Branch Circuit Protection (provided by installer)</b>		
<b>Part Number</b>	<b>Motor Size (HP)</b>	<b>(A) Power (V/PH)</b>	<b>(A) Motor Load Each (FLA)</b>	<b>Panel Load Total (FLA)</b>	<b>Non-time Delay Fuse</b>	<b>Time Delay Fuse</b>	<b>Inverse Time Circuit Breaker</b>
SEH300720AJ	5	208V/3	16.7	103	150A	125A	150A
SEH300720HPAJ	5	208V/3	16.7	103	150A	125A	150A
SEH300730AJ	5	230V/3	15.2	94	125A	110A	125A
SEH300730HPAJ	5	230V/3	15.2	94	125A	110A	125A
SEH300780AJ	5	380V/3	9.7	60	80A	70A	75A
SEH300780HPAJ	5	380V/3	9.7	60	80A	70A	75A
SEH300740AJ	5	460V/3	7.6	48	65A	55A	60A
SEH300740HPAJ	5	460V/3	7.6	48	65A	55A	60A
SEH300770AJ	5	575V/3	6.1	39	55A	45A	50A
SEH300770HPAJ	5	575V/3	6.1	39	55A	45A	50A
SEO400720AJ	5	208V/3	16.7	136	175A	150A	175A
SEO400720HPAJ	5	208V/3	16.7	136	175A	150A	175A
SEO400730AJ	5	230V/3	15.2	124	175A	150A	150A
SEO400730HPAJ	5	230V/3	15.2	124	175A	150A	150A
SEO400780AJ	5	380V/3	9.7	80	100A	90A	100A
SEO400780HPAJ	5	380V/3	9.7	80	100A	90A	100A
SEO400740AJ	5	460V/3	7.6	63	80A	70A	75A
SEO400740HPAJ	5	460V/3	7.6	63	80A	70A	75A
SEO400770AJ	5	575V/3	6.1	51	65A	60A	60A
SEO400770HPAJ	5	575V/3	6.1	51	65A	60A	60A

# 30HP - 40HP Scroll Enclosure Air Compressors

## ELECTRICAL DIAGRAM

WIRING PAGE 1  
SE04007(HP)

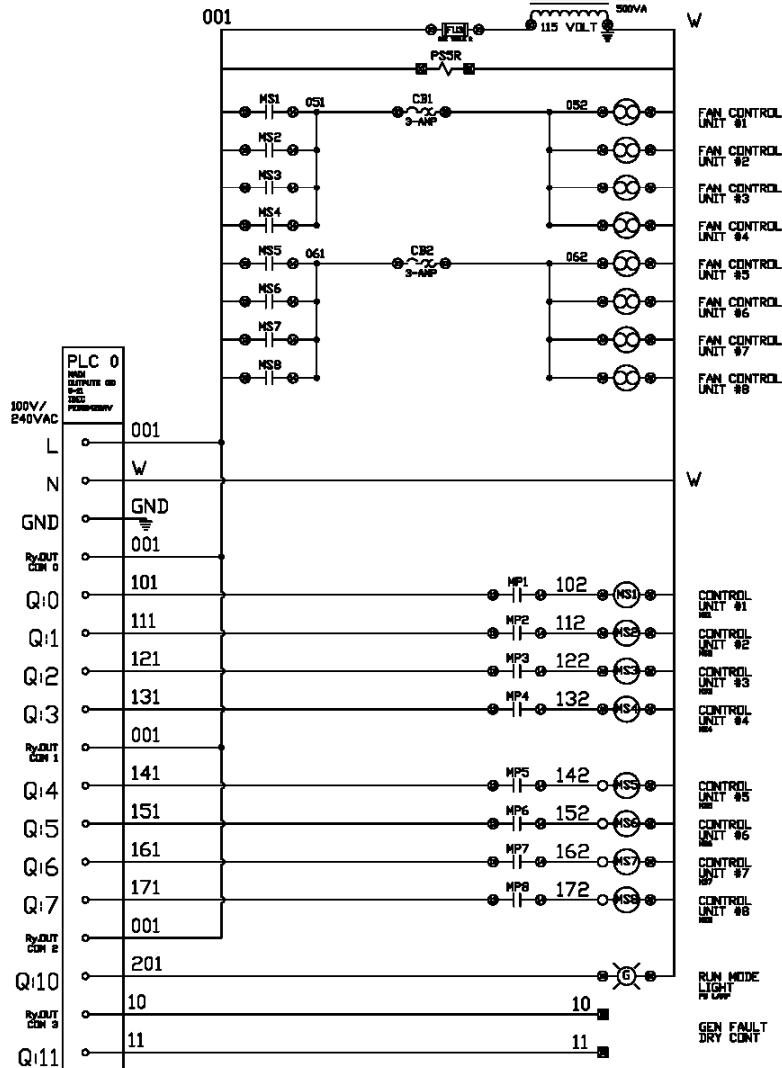
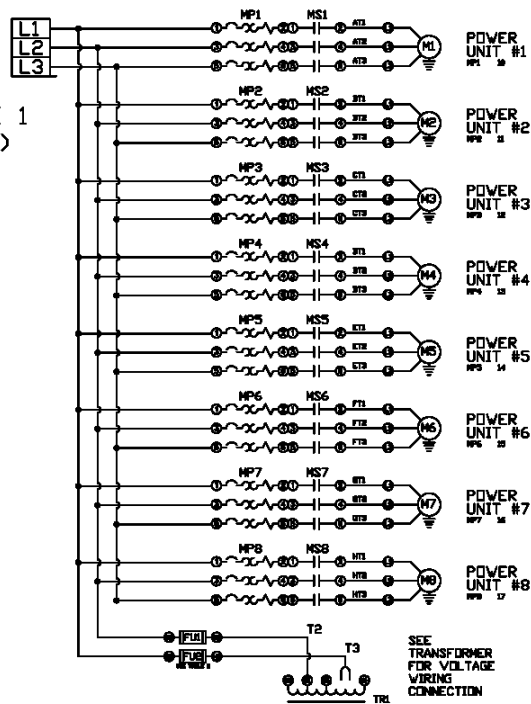



ELECTRICAL DIAGRAM

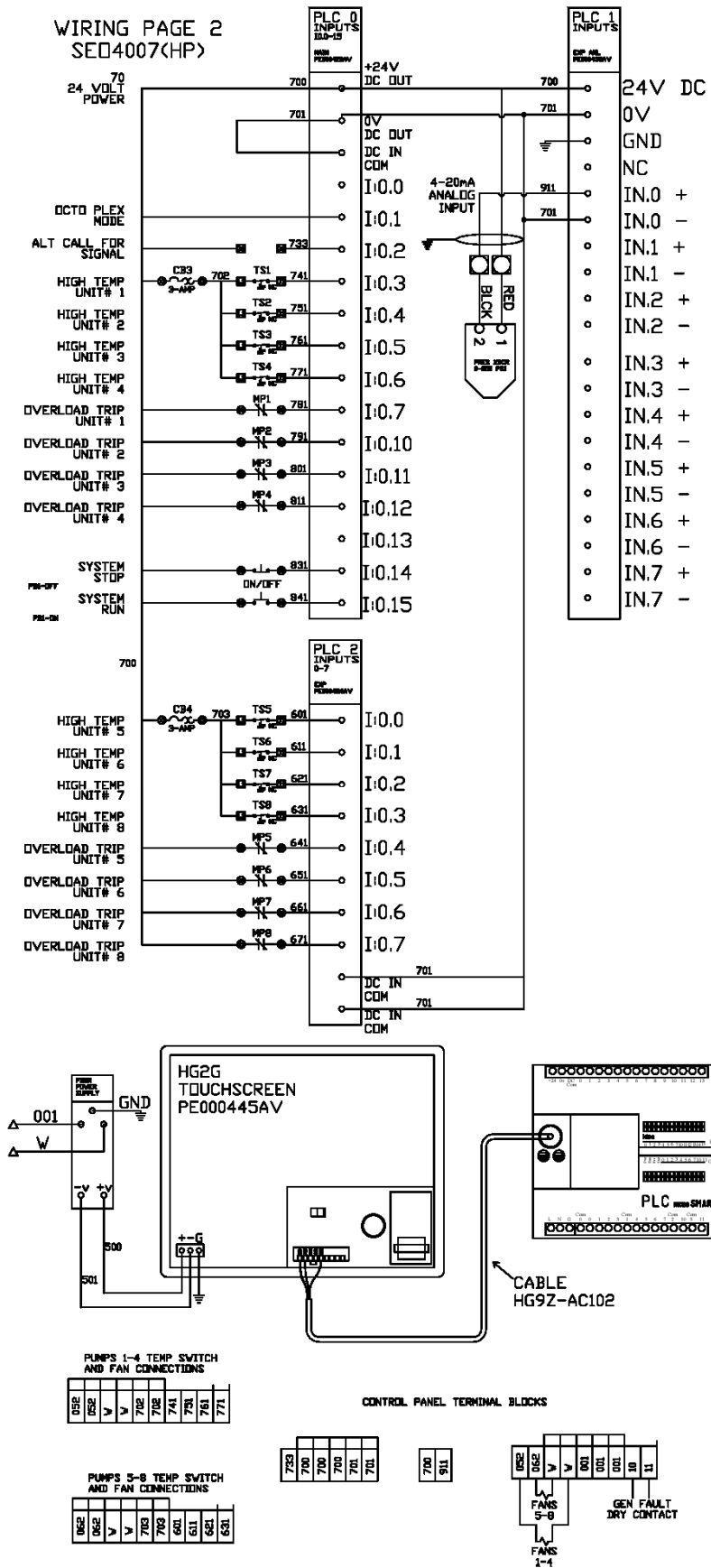

# 30HP - 40HP Scroll Enclosure Air Compressors

## PARTS DIAGRAM

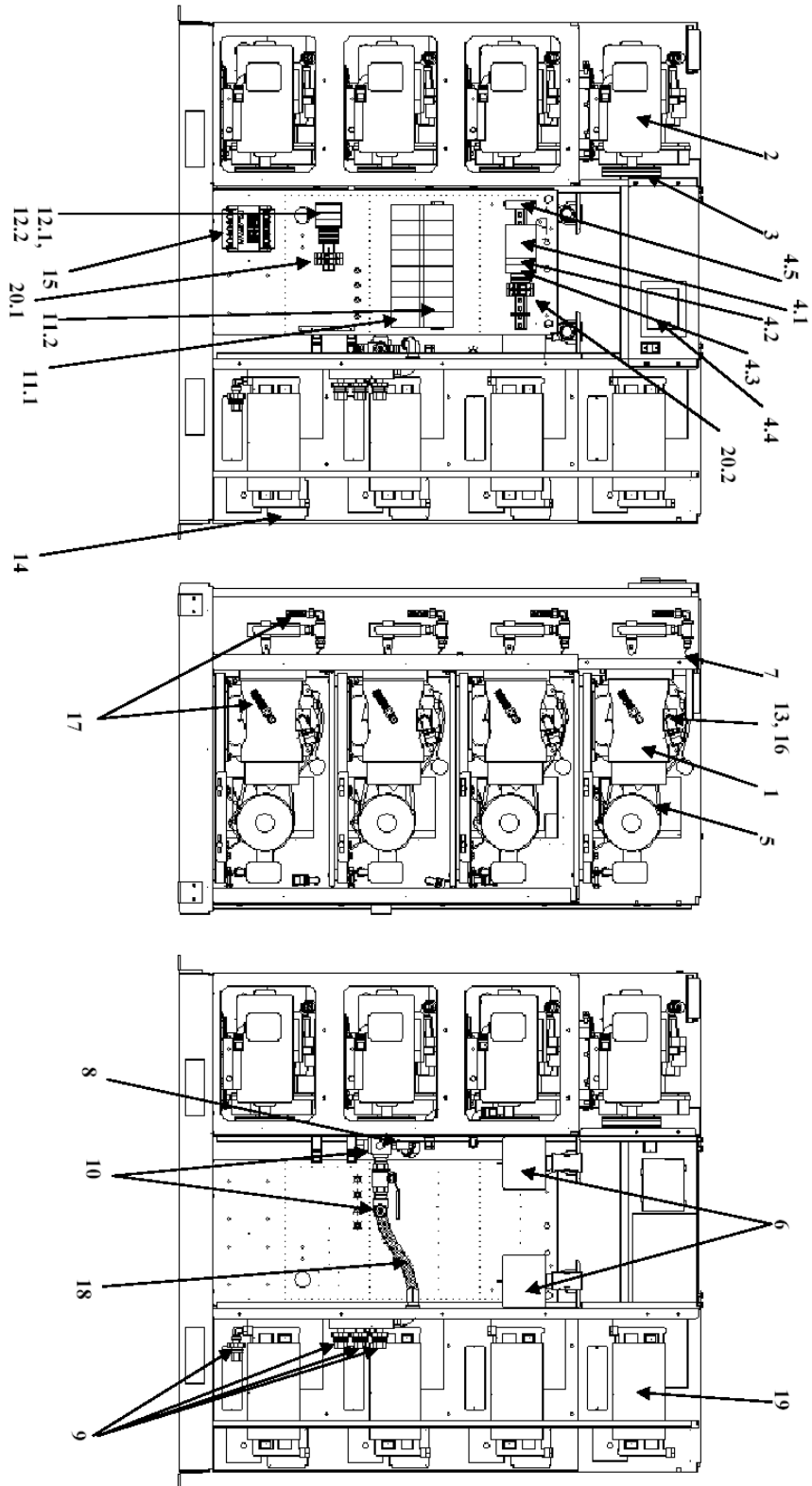

## 30HP - 40HP Scroll Enclosure Air Compressors

### REPLACEMENT PARTS LIST (Chart 9)

Ref. No.	Description	30 HP		40 HP		Qty.
		SEH3007	SEH3007HP	SEO4007	SEO4007HP	
1	Air End	SL016502AJ	SL016511AJ	SL016502AJ	SL016511AJ	6,8
2	Motor 208-230/460V		MC303305AV			6,8
	Motor 380V		MC303306AV			6,8
	Motor 575V		MC303307AV			6,8
3	Motor Pulley		PU009754AV (PU202608AV for 380V)			6,8
4.1	PLC		PE000420AV			1
4.2	Analog Input Cord		PE000438AV			1
4.3	Additional Input Card		PE000424AV			1
4.4	Touch Screen HMI panel		PE000445AV			1
4.5	Power Supply		PE000430AV			1
5	3VX-belt		BT012900AV (BT013800AV for 380V)			12,16
6	Intake filter element		ST073907AV			2
7	Temp Switch	AM003011AV	AM003012AV	AM003011AV	AM003012AV	6,8
8	Pressure Sensor		PE000440AV			1
9	Check Valve		IP087700AV			6,8
10	Safety Valve	V-215400AV	V-215401AV	V-215400AV	V-215401AV	2
11.1	Magnetic Contactor		PE000102AV			6,8
11.2	Motor Protector 208-230V		PE000307AV			6,8
	Motor Protector 380V		PE000306AV			6,8
	Motor Protector 460V/575V		PE000305AV			6,8
12.1	Distribution Block		PE000622AV			1
12.2	Distribution Block Cover		PE000640AV			1
13	Inlet Plate		IP088400AV			6,8
14	Exhaust fan		SM001301AV			6,8
15	Control Transformer 208-230/460		PS005850AV			1
	Control Transformer 380V		PS005846AV			1
	Control Transformer 575V		PS005839AV			1
16	Inlet Gasket		IP088200AV			6,8
17	Braided Hose-pump		SM001501AV			6,8
18	Braided Hose-manifold		SM001503AV			2
19	Aftercooler		SL300100AV			6,8
20.1	Circuit Breakers—Exhaust Fans		PE001355AV			2
20.2	Circuit Breakers—Temperature Switches		PE001355AV			2

## Powerex Limited Warranty

### **Warranty and Remedies.**

**(a) General.** Powerex warrants each Compressor System, Vacuum System, Vacuum Pump, Compressor Air-End, or Powerex branded Accessory (collectively "Products", individually each a "Product") to be free from defects in material and workmanship ("Defects") at the date of shipment. EXCEPT AS SET FORTH BELOW, NO OTHER WARRANTY, WHETHER EXPRESS OR IMPLIED, INCLUDING ANY WARRANTY OF MERCHANTABILITY OR FITNESS FOR A PARTICULAR PURPOSE, SHALL EXIST IN CONNECTION WITH THE SALE OR USE OF SUCH PRODUCTS. TO THE EXTENT PERMITTED BY LAW, ANY AND ALL IMPLIED WARRANTIES ARE EXCLUDED. All claims under this warranty must be made in writing and delivered to Powerex, or such claim shall be barred. Upon timely receipt of a claim, Powerex shall inspect the Product claimed to have a Defect, and Powerex shall repair, or, at its option, replace, free of charge, any Product which it determines to have had a Defect at the time of shipment from Powerex; provided, however, that if circumstances are such as to preclude the remedying of Defect by repair or replacement, Powerex shall, upon return of the Product, refund to buyer any part of the purchase price of such Products paid to Powerex. Freight for returning Products to Powerex for inspection shall be paid by buyer. The warranties and remedies herein are the sole and exclusive remedy for any breach of warranty or for any other claim based on any Defect, or non-performance of the Products, whether based upon contract, warranty or negligence.

**(b) Initial Period of Warranty – Parts and Labor.** Powerex warrants and represents all Products shall be free from Defects for the first twelve (12) months from the date of shipment by Powerex, or five thousand (5,000) hours of use, whichever occurs first. During such warranty period, Powerex shall be fully liable for all Defects in the Products (the "Product Defects"), i.e., all costs of repair or replacement, which may include "in and out" charges, so long as the Products are located in the continental United States, and the Products are reasonably located and accessible by service personnel for removal. "In and out" charges include the costs of removing a Product from buyer's equipment for repair or replacement.

**(c) Additional Period of Warranty – Parts Only (No Labor).** In addition to the above, Powerex warrants each Powerex branded Compressor Air-End, and Vacuum Pump shall be free of Defects for a period of thirty-six months from the date of shipment of Product, or 10,000 hours of use, whichever occurs first. Supplier's repair or replacement of any Product shall not extend the period of any warranty of any Product. This warranty applies to the exchange of part(s) found to be defective by an Authorized Powerex Service Center only.

**(d) Coverage.** The above mentioned warranty applies to Powerex manufactured units or systems only.

**(e) Exceptions.** Notwithstanding anything to the contrary herein, Powerex shall have no warranty obligations with respect to Products:

- (i) that have not been installed in accordance with Powerex's written specifications and instructions;
- (ii) that have not been maintained in accordance with Powerex's written instructions;
- (iii) that have been materially modified without the prior written approval of Powerex; or
- (iv) that experience failures resulting from operation, either intentional or otherwise, in excess of rated capacities or in an otherwise improper manner.

(f) The warranty provided herein shall not apply to: (i) any defects arising from corrosion, abrasion, use of insoluble lubricants, or negligent attendance to or faulty operation of the Products; (ii) ordinary wear and tear of the Products; or (iii) defects arising from abnormal conditions of temperature, dirt or corrosive matter; (iv) any OEM component which is shipped by Powerex with the original manufacturer's warranty, which shall be the sole applicable warranty for such component.

**Limitation of Liability.** TO THE EXTENT ALLOWABLE UNDER APPLICABLE LAW, NOTWITHSTANDING ANYTHING TO THE CONTRARY HEREIN, UNDER NO CIRCUMSTANCES SHALL POWEREX BE LIABLE FOR ANY INCIDENTAL, CONSEQUENTIAL, PUNITIVE, SPECULATIVE OR INDIRECT LOSSES OR DAMAGES WHATSOEVER ARISING OUT OF OR IN ANY WAY RELATED TO ANY OF THE PRODUCTS OR GOODS SOLD OR AGREED TO BE SOLD BY POWEREX TO BUYER. TO THE EXTENT ALLOWABLE UNDER APPLICABLE LAW, POWEREX'S LIABILITY IN ALL EVENTS IS LIMITED TO, AND SHALL NOT EXCEED, THE PURCHASE PRICE PAID.

**Warranty Disclaimer.** Powerex has made a diligent effort to illustrate and describe the Products in this literature accurately; however, such illustrations and descriptions are for the sole purpose of identification, and do not express or imply a warranty that the Products are merchantable, or fit for a particular purpose, or that the Products will necessarily conform to the illustrations or descriptions.

**Product Suitability.** Many jurisdictions have codes and regulations governing sales, construction, installation, and/or use of Products for certain purposes, which may vary from those in neighboring areas. While Powerex attempts to assure that its Products comply with such codes, it cannot guarantee compliance, and cannot be responsible for how the product is installed or used. Before purchase and use of a Product, please review the Product applications, and national and local codes and regulations, and be sure that the Product, installation, and use will comply with them.

**Claims.** Claims pertaining to the Products, with the exception of warranty claims, must be filed with Powerex within 6 months of the invoice date, or they will not be honored. Prices, discounts, and terms are subject to change without notice or as stipulated in specific Product quotations. All agreements are contingent upon strikes, accidents, or other causes beyond our control. All shipments are carefully inspected and counted before leaving the factory. Please inspect carefully any receipt of Products noting any discrepancy or damage on the carrier's freight bill at the time of delivery. Discrepancies or damage which obviously occurred in transit are the carrier's responsibility and related claims should be made promptly directly to the carrier. Returned Products will not be accepted without prior written authorization by Powerex and deductions from invoices for shortage or damage claims will not be allowed. **UNLESS OTHERWISE AGREED TO IN WRITING, THESE TERMS AND CONDITIONS WILL CONTROL IN ANY TRANSACTION WITH POWEREX** any different or conflicting terms as may appear on any order form now or later submitted by the buyer. All orders are subject to acceptance by Powerex.