

2 HP - 5 HP Scroll Enclosure Air Compressors

Please read and save these instructions. Read carefully before attempting to assemble, install, operate or maintain the product described. Protect yourself and others by observing all safety information. Failure to comply with instructions could result in personal injury and/or property damage! Retain instructions for future reference.

Description

GENERAL

The Powerex Oilless Rotary Scroll Air Compressor has advanced scroll compressor technology through the development of a completely oilless compressor. The Powerex Scroll Compressor offers a dynamically balanced air end which insures vibration-free operation. The rotary design permits a continuous 100% duty cycle.

Other standard features on the Powerex Scroll Compressor include: a Magnetic Starter, Motor Overload Protection, a High Temperature Shutdown Switch, an Air Cooled Aftercooler and a Single Phase or Three Phase 4 Pole ODP motor.

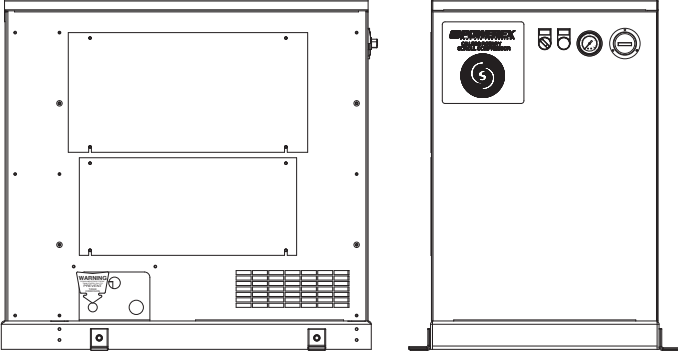

Safety Guidelines

A SEPARATE SAFETY BOOKLET IS PROVIDED ALONG WITH THIS MANUAL. READ AND UNDERSTAND The SAFETY BOOKLET. This manual contains information that is very important to know and understand. This information is provided for SAFETY and to PREVENT EQUIPMENT PROBLEMS. To help recognize this information, observe the following symbols. MAKE SURE EVERYONE OPERATING OR SERVICING THE COMPRESSOR READS AND UNDERSTANDS ALL The INFORMATION PROVIDED.

⚠ DANGER *Danger indicates an imminently hazardous situation which, if not avoided, WILL result in death or serious injury.*

⚠ WARNING *Warning indicates a potentially hazardous situation which, if not avoided, COULD result in death or serious injury.*

⚠ CAUTION *Caution indicates a potentially minor or moderate injury.*

Installation

INSTALLATION SITE

1. The scroll compressor must be located in a clean, well lit and well ventilated area.
2. The area should be free of excessive dust, toxic or flammable gases, moisture, water, and direct sunlight.
3. Never install the compressor where the ambient temperature is higher than 104° F or where humidity is high.
4. Clearance must allow for safe, effective inspection

Specifications

Product	SES Series Powerex Simplex Air Compressors	
Performance Specifications	See Page 2	
Lubrication	Grease-filled Bearing	
Operating Voltages	1Ø	230 Volts, 60 Hz; 230 Volts, 50 Hz
	3Ø	208-230/460 Volts, 60 Hz
Compression Cycle	Scroll	
Motor Overload Protection	IEC Motor Overload Relay	
Pressure Settings	Cut-In: 95 psig	Cut-Out: 115 psig
	Cut-In: 115 psig	Cut-Out: 145 psig (High Pressure Unit)
Overpressure Protection	ASME Safety Valve Factory Set and Sealed	
Outlet Air Connections	3/8 inch NPT	
Tank Size	13 Gallon ASME Rated 175 psig	
California Ordinance 462 (L) (2)	Meets Requirements of this Ordinance	
Tank Isolation	Standard All Units	
Drive	3V Belt	
Control Panel	UL508A Listed	

2 HP - 5 HP Scroll Enclosure Air Compressors

Compressor Specifications

Model	SES02	SES03	SES13	SES05	SES15
HP	2	3		5	
Phase	3Ø	3Ø	1Ø	3Ø	1Ø
Voltage	208 - 230 / 460	208 - 230 / 460	230	208 - 230 / 460	230
Amps	See wiring diagram for amp rating				
Air End	SLAE03EB	SLAE03EB		SLAE05E (SLAE05EHP)	
Control System	Pressure Switch	Pressure Switch		Pressure Switch	
Discharge Pressure (PSIG)	95 - 115 (115 - 145 optional)	95 - 115 (115 - 145 optional)		95 - 115 (115 - 145 optional)	
Air Delivery (CFM)	6.0 @ 100 PSIG and (4.6 @ 145 PSIG)	8.8 @ 100 PSIG and (7.1 @ 145 PSIG)		15.2 @ 100 PSIG and (12.5 @ 145 PSIG)	
Compressor Speed (RPM)	2200 (1850)	3140 (2770)		3250 (3250)	
Discharge Temp.	Ambient temp. + 30 °F	Ambient temp. + 30 °F		Ambient temp. + 30 °F	
Noise level dB(A) [1.5m from front]	49	49		51	
Dimensions In Inches (L x W x H)	34 x 21 x 32.5	34 x 21 x 32.5		34 x 21 x 32.5	
Approximate Weight	309 lbs.	309 lbs.		359 lbs	

(Items in paranthesis high pressure information)

and maintenance. 20 inches of clearance for sides is recommended.

- If necessary, use metal shims or leveling pads to level the compressor. Never use wood to shim the compressor.
- Never install the compressor outside.
- For 3 and 5 HP single phase models it is recommended that additional tank volume be added. 3 HP single phase models need a minimum of 30 gallons air capacity to limit the number of starts-per-hour to 14 maximum. 5 HP single phase models need a minimum of 60 gallons air capacity to limit the number of starts-per-hour to 10 maximum.

VENTILATION

- If the scroll compressor is located in a totally enclosed room, an exhaust fan with access to outside air must be installed.
- Never restrict the cooling fan exhaust air.
- Vent the exhaust air outside to prevent the compressor from operating at high temperatures and shutting down.
- Never locate the compressor where hot exhaust air from other heat generating units may be pulled into the unit.

WIRING

All electrical connections must be performed by a qualified electrician. Installations must be in accordance with local and national electrical codes.

- Make sure power source is the same voltage as the unit's required voltage
- Use solderless terminals to connect the electric power source.
- Remove the two left panels.
- Pull the electric cable through the electric source inlet and connect to the primary side of the contact blocks.
- Since loosening of wires is possible in shipment, tighten all wire terminals prior to starting the unit.

PIPING

General Guidelines

- Make sure the piping is lined up without being strained or twisted when assembling the piping for the scroll

compressor.

- Appropriate expansion loops or bends should be installed at the compressor to avoid stresses caused by changes in hot and cold conditions.
- Piping supports should be anchored separately from the compressor to reduce noise and vibration.
- Never use any piping smaller than the compressor connection.
- Use flexible hose to connect the outlet of the compressor to the piping so that the vibration of the compressor does not transfer to the piping.

Remote Intake Piping

Powerex Compressor Systems with pipe thread connectors on the intake filters are intended for installation with remote air intake. Piping for the remote intake system must be installed at the final operating site.

Under some conditions, the intake piping may facilitate the condensation of humidity in the intake air stream into liquid water.

NOTICE

The intake filters supplied by Powerex will not stop ingestion of liquid water by the pumps. Liquid water going into the pumps will damage the pumps and void the warranty.

Always install drip legs with sufficient capacity to capture liquid water in the intake piping before the air filters. Drip legs must be sized with low enough air velocity to make sure they are effective at capturing liquid water in the intake air and must be maintained (drained) at frequent intervals to make sure they remain effective.

SAFETY VALVES

Tank mounted compressors are shipped from the factory with safety valves installed in the air receiver manifold. The flow capacity of the safety valve is equal to or greater than the capacity of the compressor.

- The pressure setting of the safety valve must be equal or less than the maximum working pressure of the air receiver.

2. Safety valves should be placed ahead of any possible blockage point in the system, i.e. shutoff valve.
3. Avoid connecting the safety valve with any tubing or piping.
4. Manually operate the safety valve every six months to avoid sticking or freezing.

Operation

BEFORE START UP

1. Make sure all safety warnings, labels and instructions have been read and understood before continuing.
2. Remove any shipping materials, brackets, etc.
3. Confirm that the electric power source and ground have been firmly connected.
4. Check the belts for tightness.
5. Be sure all pressure connections are tight.
6. Check to be certain all safety relief valves, etc., are correctly installed.
7. Securely mount all panels and guards.
8. Check that all fuses, circuit breakers, etc., are the proper size.
9. Make sure the inlet filter is properly installed.
10. Confirm that the drain valve is closed.

START-UP AND OPERATION

1. Visually check the rotation of the compressor pump. The rotation should be counterclockwise if viewing the compressor from the belt side. If the rotation is incorrect, have a qualified electrician correct the supply wiring.
2. Follow all the procedures under "Before start-up" before attempting operation of the compressor.
3. Make sure compressor switch is in the OFF position.
4. Switch the electric source breaker on.
5. Open the 3/8 inch discharge valve completely.
6. Turn compressor switch to ON position and check that the compressor operates without excessive vibration, unusual noises or leaks.
7. Close the discharge valve completely.
8. If the pressure does not rise on a three phase unit, turn the unit off. Have a qualified electrician switch the breaker OFF and exchange the L1 and L2 connections

(two out of three phases of electric source) on the control panel.

9. Check the discharge pressure. Also make sure the air pressure rises to the designated pressure setting by checking the discharge pressure gauge.
10. Check the operation of the pressure switch by opening the outlet valve and confirming the compressor starts at approximately 95 psig for low pressure units and 115 psig or high pressure units.

DAILY OPERATION

1. Stop the compressor by turning switch to the OFF position.

NOTE: If the compressor rotates in reverse for more than five seconds, the check valve needs to be cleaned or replaced.

2. Switch the breaker OFF if the compressor is not to be used for a long period of time.

STOPPING THE COMPRESSOR DURING NORMAL OPERATION

1. Close the discharge valve.
2. Allow the air pressure to build and the compressor to stop.
3. Turn the compressor off by turning switch to the OFF position.

BELT ADJUSTMENT PROCEDURE

1. Remove the top panel by removing the two slotted 1/4-20 screws on the rear of the enclosure.
2. Loosen the four (4) motor slide bolts.
3. Tighten belt by adjusting the belt adjustment bolt. Belt tension for new belts should be 57 to 65 lbs for the loosest belt in the set, then 45-50 lbs after run-in. If the belt tension falls below 25 lbs or chirping is heard as start up, re-tension belts. (If using the deflection method for belt tension, 3.8-4.3 lbs force at mid span should give 7/32" belt deflection for a new belt, 3.0-3.38 for a used belt for 7/32" belt deflection.)
4. Tighten the four (4) motor slide bolts. Tighten the two electrical panel side slide bolts first then tighten the two pulley side slide bolts.

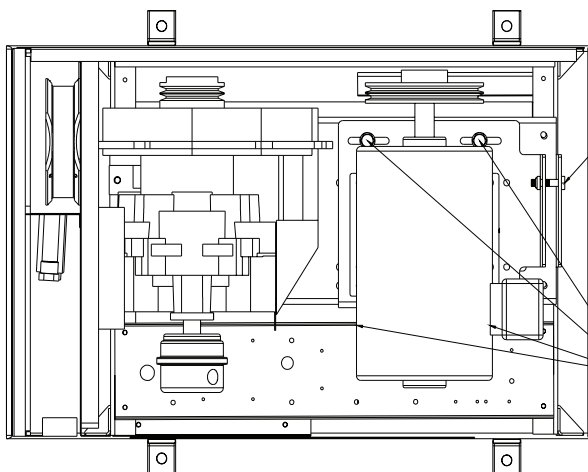

BELT ADJUSTMENT
BOLT

MOTOR SLIDE
BOLTS (4)

Figure 1

2 HP - 5 HP Scroll Enclosure Air Compressors

Scroll Unit Parts Breakdown -

Models SES02, SES12, SES03, SES13, SES05, SES15, SF120_PH, and SF130_PH

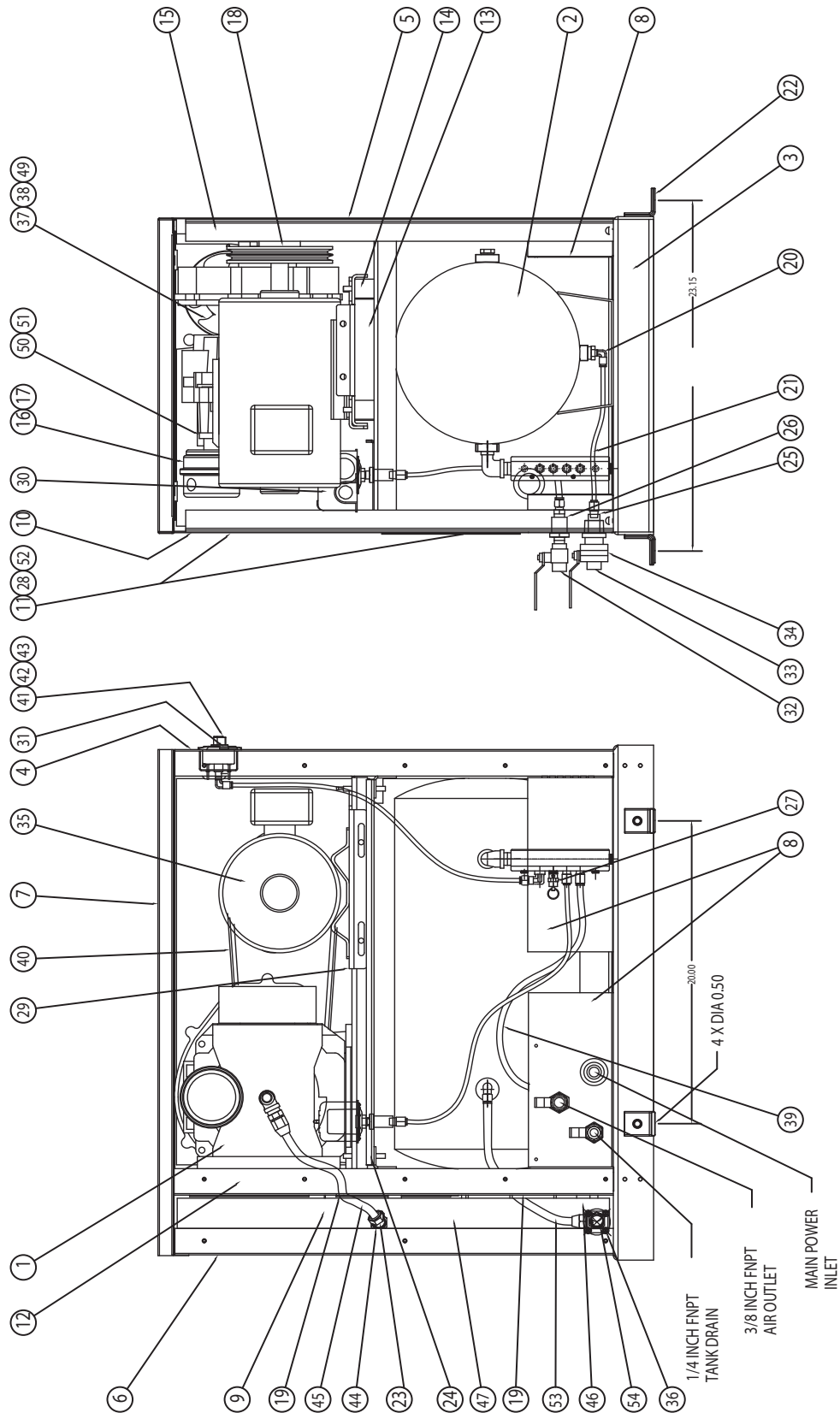

Figure 2

2 HP - 5 HP Scroll Enclosure Air Compressors

Ref. No.	Description	SES02 / SES12	SES03 / SES13	SES05 / SES15	Qty.
1	Air end (low pressure)	SL014003AJ	SL014003AJ	SL016502AJ	1
	(high pressure)	SL014003AJ	SL014003AJ	SL016511AJ	1
2	13 gallon tank	AR234800AJ	AR234800AJ	AR234800AJ	1
3	Unit base	SL303600AV	SL303600AV	SL303600AV	1
4	Front panel	SL304500AV	SL304500AV	SL304500AV	1
5	Right panel	SL304400AV	SL304400AV	SL304400AV	1
6	Back panel	SL304600AV	SL304600AV	SL304600AV	1
7	Top panel	SL304800AV	SL304800AV	SL304800AV	1
8	Utility panel	SL305200AV	SL305200AV	SL305200AV	3
9	Internal duct	SL304901AV	SL304901AV	SL304901AV	1
10	Left panel	SL304300AV	SL304300AV	SL304300AV	1
11	Maintenance panel 1	SL305000AV	SL305000AV	SL305000AV	1
12	Inside panel	SL304700AV	SL304700AV	SL304700AV	1
13	Pump base	SL304101AV	SL304101AV	SL304101AV	1
14	Mounting foot	IP630300AV	IP630300AV	IP630300AV	4
15	"H" support	SL305100AV	SL305100AV	SL305100AV	2
16	Inlet filter assembly	ST073924AV	ST073924AV	ST073924AV	1
17	Filter element	91348550	91348550	91348550	1
18	Motor pulley 2HP (low pressure, 2-3V4.45)	3Ø PU202633AV 1Ø PU202623AV	-	-	1
	2HP (high pressure, 2-3V3.65)	3Ø PU202632AV 1Ø PU202622AV	-	-	1
	3HP (low pressure, 2-3V6.0)	-	PU202625AV	-	1
	3HP (high pressure, 2-3V5.3)	-	PU202624AV	-	1
	5HP (low pressure, 2-3V6.9)	-	-	PU009754AV	1
	5HP (high pressure, 2-3V6.9)	-	-	PU009754AV	1
20	1/4 T x 1/4 P x 90° push connect	ST119702AV	ST119702AV	ST119702AV	1
21	1/4 inch drain tube	PS010300AV	PS010300AV	PS010300AV	2.0 ft.
22	Corner angle	ST185500AV	ST185500AV	ST185500AV	4
23	Temperature switch @ 115 psi	AM003011AV	AM003011AV	AM003011AV	1
	Temperature switch @ 145 psi	AM003012AV	AM003012AV	AM003012AV	1
24	Sub panel	SL305300AV	SL305300AV	SL305300AV	1
25	1/4 inch bulk head fitting	PS006701AV	PS006701AV	PS006701AV	1
26	3/8 inch bulk head fitting	PS006702AV	PS006702AV	PS006702AV	1
27	Safety valve (Low pressure unit)	V-215104AV	V-215104AV	V-215104AV	1
	(High pressure unit)	V-215401AV	V-215401AV	V-215401AV	1
28	Maintenance panel 2	SL306500AV	SL306500AV	SL306500AV	1
29	Motor slide base	SL306701AV	SL306701AV	SL306701AV	1
30	Pressure switch (Low pressure unit)	CW207573AV	CW207573AV	CW207573AV	1

2 HP - 5 HP Scroll Enclosure Air Compressors

Ref. No.	Description	SES02 / SES12	SES03 / SES13	SES05 / SES15	Qty.
	(High pressure unit)	CW207595AV	CW207595AV	CW207595AV	1
31	Lighted off/on switch	PE000560AV	PE000560AV	PE000560AV	1
32	3/8 inch ball valve	ST079802AV	ST079802AV	ST079802AV	1
33	1/4 inch ball valve	ST079806AV	ST079806AV	ST079806AV	1
34	Electrical strain relief	ST188106AV	ST188106AV	ST188106AV	1
35	Motor				
	2hp 1 phase	MC301579AV	-	-	1
	2hp 3 phase	MC301514AV	-	-	1
	3hp 1 phase	-	MC301579AV	-	1
	3hp 3 phase	-	MC303301AV	-	1
	5hp 1 phase	-	-	MC022393AV	1
	5hp 3 phase	-	-	MC303303AV	1
36	Check valve	IP087700AV	IP087700AV	IP087700AV	1
37	Fan	IP632400AV	IP632400AV	IP632400AV	1
38	Fan guard	IP632401AV	IP632401AV	IP632401AV	1
39	3/8 inch PTFE tube	PS001800AV	PS001800AV	PS001800AV	2.5 ft.
40	Belt				
	2hp low pressure	BT009001AV	-	-	2
	2hp high pressure	BT009001AV	-	-	2
	3hp low pressure	-	BT013800AV	-	2
	3hp high pressure	-	BT012001AV	-	2
	5hp low/high pressure	-	-	BT010701AV	2
41	High temp light	PE000538AV	PE000538AV	PE000538AV	1
42	Unit pressure gauge	IP632601AV GA032201AV (PH UNIT)	IP632601AV -	IP632601AV -	1 1
43	Hourmeter	PE001004AV	PE001004AV	PE001004AV	1
44	Jic fitting	ST186422AV	ST186422AV	ST186422AV	1
45	Braided hose	SM001502AV	SM001502AV	SM001502AV	1
46	Rubber mounting block	AG007501AV	AG007501AV	AG007501AV	3
47	After cooler	SL300101AV	SL300101AV	SL300101AV	1
48	◆ Cabinet screw	ST129304AV	ST129304AV	ST129304AV	32
49	Fan cord	IP632800AV	IP632800AV	IP632800AV	1
50	Intake adaptor plate	IP088400AV	IP088400AV	IP088400AV	1
51	Adaptor plate gasket	IP088200AV	IP088200AV	IP088200AV	1
52	1/4 - 20 screw	ST074003AV	ST074003AV	ST074003AV	8
53	3/8 inch PTFE tube	PS001800AV	PS001800AV	PS001800AV	1 ft.
54	3/8 x 3/8 x 90 push connect	ST119705AV	ST119705AV	ST119705AV	2
◆= Not shown					
Parts unique to:		SF120_PH	SF130_PH	-	
3	Deep base	SL305401AV	SL305401AV	-	1
18	Motor pulley (50 Hz)	PU202623AV	PU202626AV	-	1
35	Motor (50 Hz)	MC301578AV	MC301578AV	-	1
40	Belt (50 Hz)	BT012001AV	BT010701AV	-	2
42	Gauge	GA032201AV	GA032201AV	-	1

2 HP - 5 HP Scroll Enclosure Air Compressors

Maintenance Schedule (see Pump Manual for "How To" Instructions)

Item	Action needed	Operating Hours					Remarks
		500	2500	5000	10,000	20,000	
Receiver	Drain moisture	Daily					If equipped with an Electric Drain, test daily
Cartridge Filter	Clean, Replace	●	▲				Part # 91348550
Ventilation Screen	Clean	●					
Blower Fan	Clean			●			
Fan Duct	Clean			●			
Compressor Fins	Clean			●			
Compressor	Regrease			▲ (Every 5000 hours for 145 psig units)	▲	▲	Use genuine Powerex grease
Tip Seal Set	Replace			▲ (Every 5000 hours for 145 psig units)	▲	▲	
Heat Insulation Pipe	Replace			▲ (Every 5000 hours for 145 psig units)	▲	▲	
V-belt	Inspect, Replace		Readjust ●	▲	▲	▲	
Temperature Sensor	Confirm operation					●	
Pressure Switch	Confirm operation				●		
Magnetic Starter	Inspect				●		Replace is contact point is deteriorated
Safety Valve	Confirm operation				●		
Pressure Gauge	Inspect				●		
Ventilation Fan	Inspect				●		Replace if malfunctions

● Inspect

▲ Replace

Notes:

1. Inspect and perform maintenance periodically according to maintenance schedule.
2. The maintenance schedule relates to the normal operating conditions. If the circumstances and load condition are adverse, shorten the interval time and perform maintenance accordingly.
3. Marked "Readjust" means the tension of the V-belt should be adjusted during the initial stage and inspected every 2,500 hours afterwards; 57-65 lbs initially, then 45-50 lbs after run-in.

2 HP - 5 HP Scroll Enclosure Air Compressors

Electrical Diagram - Single Phase Units 230 Volts

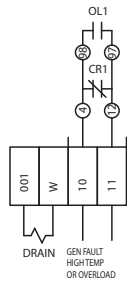
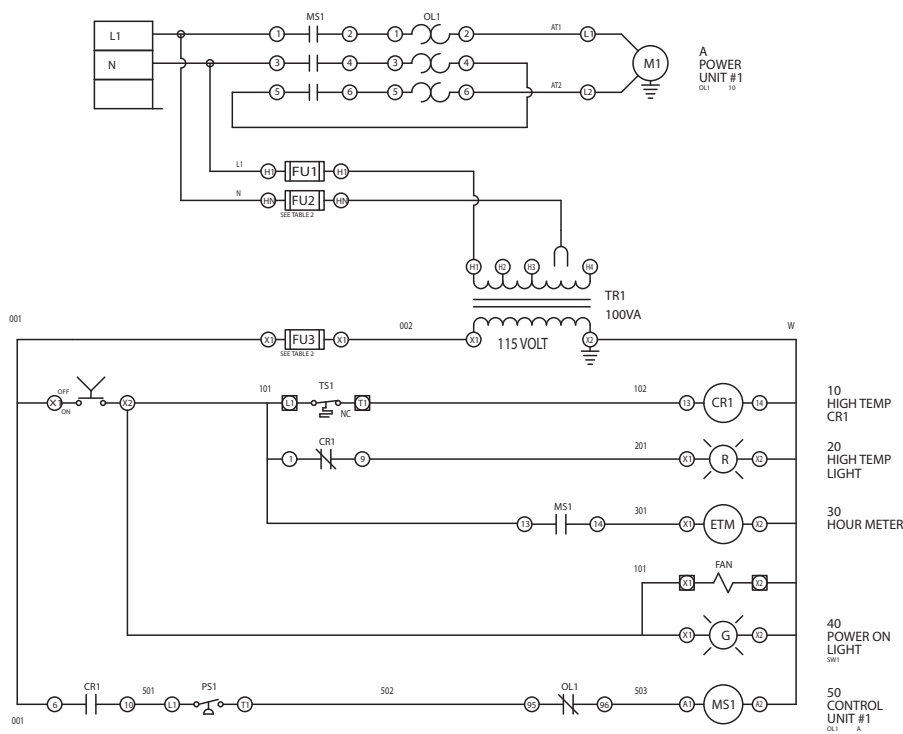

NOTES:

- RECOMMENDED TIGHTENING TORQUES FOR WIRE TERMINALS:
 208-460 VOLT POWER 35 POUND INCHES
 115 VOLT POWER, CONTROL AND LOW VOLTAGE 20 POUND INCHES
- PANEL GROUND MUST BE CONNECTED TO EARTH GROUND
- INSTALLER TO PROVIDE MAIN DISCONNECTING DEVICE WITH SHORT CIRCUIT PROTECTION FOR EACH MOTOR CIRCUIT IN THIS ELECTRICAL ASSEMBLY. SEE TABLE 1
- ALL WIRES MUST BE LABELED ON BOTH ENDS
- INCOMING VOLTAGE MUST BE 4-WIRE DELTA OR 4-WIRE STAR WITH NEUTRAL.

TABLE 1

PANEL DATA 1 ϕ - 50/60 Hz 100VA CONTROL CIRCUIT					(B) BRANCH CIRCUIT PROTECTION - PROVIDED BY INSTALLER		
LOAD SPECIFICATIONS							
PANEL PART NUMBER	MOTOR SIZE EACH (HP)	POWER (V/PH)	MOTOR LOAD EACH (FLA)	PANEL LOAD TOTAL (FLA)	MONTHLY DELAY FUSE	TIME-DELAY FUSE	INVERSE-TIME CIRCUIT BREAKER
ZZ005390AJ	2	230V/1 ϕ	12.6	14.6	45A	30A	40A
ZZ005386AJ	3	230V/1 ϕ	12.6	14.6	45A	30A	40A
ZZ005382AJ	5	230V/1 ϕ	23.0	25.0	80A	50A	60A

NOTE- ADJUST OVERCURRENT PROTECTION DEVICE NOT TO EXCEED 100% OF MOTOR NAMEPLATE FLA VALUE

USE PANEL LAYOUT B

Figure 3

2 HP - 5 HP Scroll Enclosure Air Compressors

Electrical Diagram - Three Phase Units 208 - 230 - 460 Volts

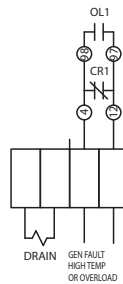
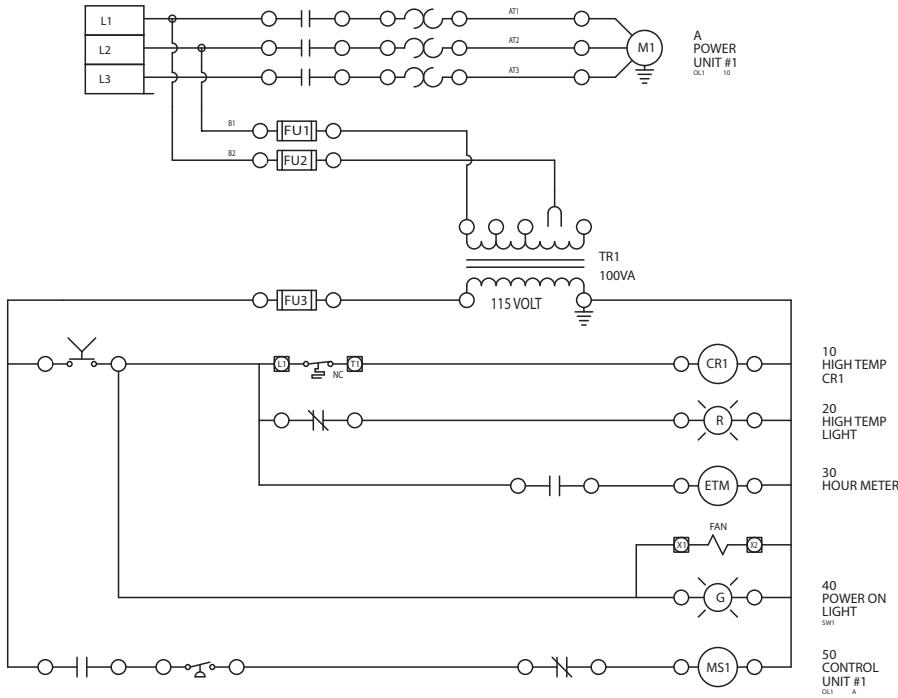

NOTES:

1. RECOMMENDED TIGHTENING TORQUES FOR WIRE TERMINALS:
 208-460 VOLT POWER 35 POUND INCHES
 115 VOLT POWER, CONTROL AND LOW VOLTAGE 20 POUND INCHES
2. PANEL GROUND MUST BE CONNECTED TO EARTH GROUND
3. INSTALLER TO PROVIDE MAIN DISCONNECTING DEVICE WITH SHORT CIRCUIT PROTECTION FOR EACH MOTOR CIRCUIT IN THIS ELECTRICAL ASSEMBLY. SEE TABLE 1
4. ALL WIRES MUST BE LABELED ON BOTH ENDS
5. INCOMING VOLTAGE MUST BE 4-WIRE DELTA OR 4-WIRE STAR WITH NEUTRAL.

TABLE 1

PANEL DATA 3 ϕ - 50/60 Hz 100VA CONTROL CIRCUIT					(B) BRANCH CIRCUIT PROTECTION - PROVIDED BY INSTALLER		
LOAD SPECIFICATIONS					NONTIME DELAY FUSE	TIME-DELAY FUSE	INVERSE-TIME CIRCUIT BREAKER
PANEL PART NUMBER	MOTOR SIZE EACH (HP)	POWER (V/Ph)	MOTOR LOAD EACH (FLA)	PANEL LOAD TOTAL (FLA)			
ZZ005389AJ	2	208V/3 ϕ	7.5	8	25A	15A	20A
ZZ005385AJ	3	208V/3 ϕ	10.6	11	35A	20A	30A
ZZ005381AJ	5	208V/3 ϕ	16.7	17	50A	30A	45A
ZZ005388AJ	2	230V/3 ϕ	6.8	7	20A	15A	20A
ZZ005384AJ	3	230V/3 ϕ	9.6	10	30A	20A	25A
ZZ005380AJ	5	230V/3 ϕ	15.2	16	50A	30A	40A
ZZ005783PX	5	380V/3 ϕ	8.3	10	30A	20A	25A
ZZ005387AJ	2	460V/3 ϕ	3.4	3.5	10A	6A	15A
ZZ005383AJ	3	460V/3 ϕ	4.8	5	15A	10A	15A
ZZ005368AJ	5	460V/3 ϕ	7.6	8	25A	15A	20A
ZZ005785PX	3	575V/3 ϕ	3.9	6	15A	10A	15A
ZZ005786PX	5	575V/3 ϕ	6.1	8	20A	15A	20A

NOTE- ADJUST OVERCURRENT PROTECTION DEVICE NOT TO EXCEED 115% OF MOTOR NAMEPLATE FLA VALUE

Figure 4

2 HP - 5 HP Scroll Enclosure Air Compressors

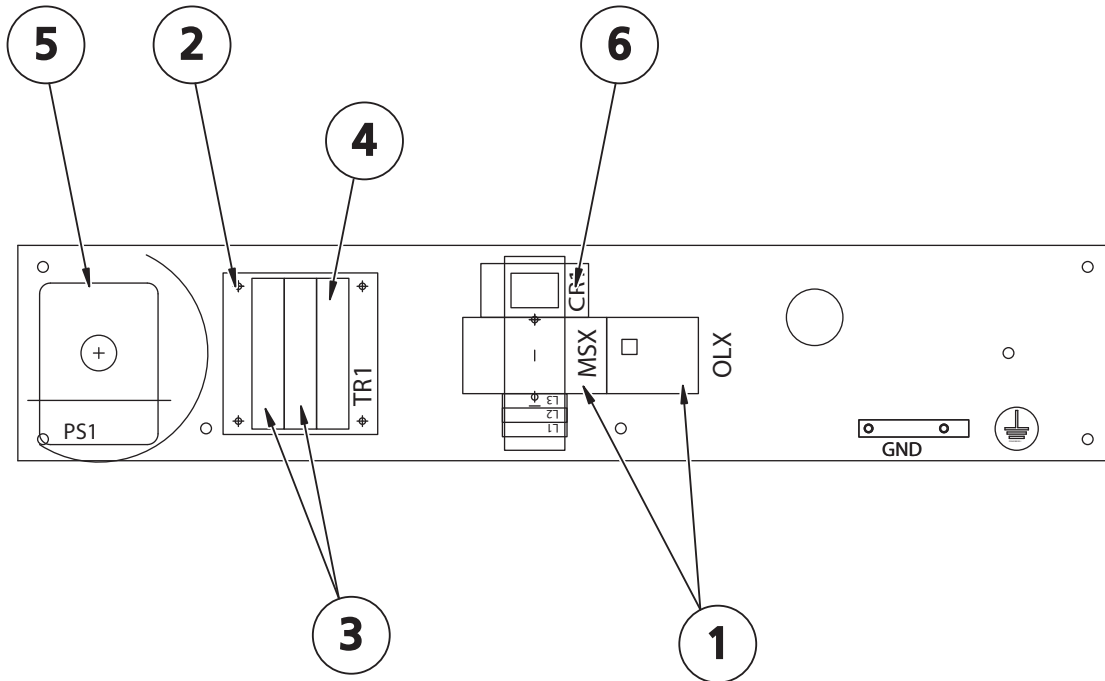

Figure 5

Scroll Electrical Panel Replacement Parts

Key #	Model	HP	1 Motor Starter / Overload Relay	2 Control Transformer	3 Fuse 1 / Fuse 2 (2 REQUIRED)	4 Fuse 3	5 Pressure Switch		6 Control Relay
							115 PSI	145 PSI	
	SES02082 208V,3P	2	PE000101AV / PE000205AV	PS005834AV	JP007707AV	JP007711AV	CW207573AV	CW207595AV	PE000403AV
	SES02083 230V,3P		PE000102AV / PE000210AV		JP007707AV				
	SES02084 460V,3P		PE000101AV / PE000204AV		JP007703AV				
	SES03082 208V,3P	3	PE000102AV / PE000206AV		JP007707AV				
	SES03083 230V,3P		PE000102AV / PE000210AV		JP007707AV				
	SES03084 460V,3P		PE000101AV / PE000204AV		JP007703AV				
	SES13086 230V,1P		PE000103AV / PE000207AV		JP007707AV				
	SES05082 208V,3P	5	PE000102AV / PE000207AV		JP007707AV				
	SES05083 230V,3P		PE000102AV / PE000207AV		JP007707AV				
	SES05084 460V,3P		PE000101AV / PE000205AV		JP007703AV				
	SES15086 208V,1P		PE000104AV / PE000209AV	JP007707AV					

Troubleshooting Guide

PROBLEM	CAUSE	CORRECTIVE ACTION
Power ON light does not appear	<ol style="list-style-type: none"> 1. Main disconnect is not ON 2. Blown fuse or circuit breaker at customer provided power supply 3. Blown fuse at transformer 4. Lighted switch is burned out 	<ol style="list-style-type: none"> 1. Switch disconnect to ON 2. Inspect for any fault replace fuse or trip disconnect to ON 3. Replace fuse - be sure to use same type and size 4. Replace lighted switch
Power ON light is on but unit will not start	<ol style="list-style-type: none"> 1. Motor overload has tripped 2. Wrong or low voltage 3. Starter has failed 4. Motor has failed 	<ol style="list-style-type: none"> 1. See last entry of Troubleshooting Guide 2. Check incoming power supply and unit power rating 3. Replace contactor assembly 4. Replace motor
Compressor is running but will not make pressure	<ol style="list-style-type: none"> 1. Drive belts came off or too loose 2. Clogged intake filter element 3. Pressure relief valve has opened 4. Excessive tip seal wear 5. Electric tank drain is open continuously 6. Unit running in the wrong direction 7. Discharge air is leaking 	<ol style="list-style-type: none"> 1. Replace drive belts and (or) tighten 2. Replace intake filter element 3. Pressure switch needs replaced or motor contacts welded shut 4. Replace tip seals 5. Replace tank drain 6. Correct power connections 7. Check discharge piping
Excessive noise or vibration	<ol style="list-style-type: none"> 1. Drive belt has separated or flat spot 2. Motor has failed 3. Pump is damaged 4. Cooling air fan is touching fan guard 	<ol style="list-style-type: none"> 1. Replace drive belt 2. Replace motor 3. Fix or replace pump 4. Check air fan daily
Compressor shuts down on high temperature	<ol style="list-style-type: none"> 1. Room temperature is above 104° F 2. Inlet air duct is obstructed 3. Cooling air fan not running 4. Aftercooler fins clogged 5. Intake filter damaged 6. Compressor is dirty 7. Tip seals worn 	<ol style="list-style-type: none"> 1. Add ventilation or air conditioning to room 2. Remove obstruction or reposition unit to allow for cooling air 3. Replace cooling air fan 4. Clean aftercooler 5. Check intake filter 6. Clean unit 7. Replace tip seals
Compressor turns on/off rapidly	<ol style="list-style-type: none"> 1. Receiver tank has high level of water 2. Compressor check valve has failed 3. Defective pressure switch 	<ol style="list-style-type: none"> 1. Replace electric tank drain/drain tank 2. Replace check valve 3. Replace pressure switch
Safety valves blows off	<ol style="list-style-type: none"> 1. Pressure switch has failed to open 2. Motor starter contacts welded shut 	<ol style="list-style-type: none"> 1. Replace pressure switch 2. Replace motor starter
Motor Overload has tripped	<ol style="list-style-type: none"> 1. Pump has failed 2. Motor has failed 3. Improper wiring 4. Wrong overload setting 5. Low voltage 	<ol style="list-style-type: none"> 1. Fix or replace pump 2. Replace motor 3. Check wiring 4. Check overload setting 5. Check incoming power supply

2 HP - 5 HP Scroll Enclosure Air Compressors

Powerex Limited Warranty

Warranty and Remedies.

(a) General. Powerex warrants each Compressor System, Vacuum System, Vacuum Pump, Compressor Air-End, or Powerex branded Accessory (collectively "Products", individually each a "Product") to be free from defects in material and workmanship ("Defects") at the date of shipment. EXCEPT AS SET FORTH BELOW, NO OTHER WARRANTY, WHETHER EXPRESS OR IMPLIED, INCLUDING ANY WARRANTY OF MERCHANTABILITY OR FITNESS FOR A PARTICULAR PURPOSE, SHALL EXIST IN CONNECTION WITH THE SALE OR USE OF SUCH PRODUCTS. TO THE EXTENT PERMITTED BY LAW, ANY AND ALL IMPLIED WARRANTIES ARE EXCLUDED. All claims under this warranty must be made in writing and delivered to Powerex, or such claim shall be barred. Upon timely receipt of a claim, Powerex shall inspect the Product claimed to have a Defect, and Powerex shall repair, or, at its option, replace, free of charge, any Product which it determines to have had a Defect at the time of shipment from Powerex; provided, however, that if circumstances are such as to preclude the remedying of Defect by repair or replacement, Powerex shall, upon return of the Product, refund to buyer any part of the purchase price of such Products paid to Powerex. Freight for returning Products to Powerex for inspection shall be paid by buyer. The warranties and remedies herein are the sole and exclusive remedy for any breach of warranty or for any other claim based on any Defect, or non-performance of the Products, whether based upon contract, warranty or negligence.

(b) Initial Period of Warranty – Parts and Labor. Powerex warrants and represents all Products shall be free from Defects for the first twelve (12) months from the date of shipment by Powerex, or five thousand (5,000) hours of use, whichever occurs first. During such warranty period, Powerex shall be fully liable for all Defects in the Products (the "Product Defects"), i.e., all costs of repair or replacement, which may include "in and out" charges, so long as the Products are located in the continental United States, and the Products are reasonably located and accessible by service personnel for removal. "In and out" charges include the costs of removing a Product from buyer's equipment for repair or replacement.

(c) Additional Period of Warranty – Parts Only (No Labor). In addition to the above, Powerex warrants each Powerex branded Compressor Air-End, and Vacuum Pump shall be free of Defects for a period of thirty-six months from the date of shipment of Product, or 10,000 hours of use, whichever occurs first. Supplier's repair or replacement of any Product shall not extend the period of any warranty of any Product. This warranty applies to the exchange of part(s) found to be defective by an Authorized Powerex Service Center only.

(d) Coverage. The above mentioned warranty applies to Powerex manufactured units or systems only.

(e) Exceptions. Notwithstanding anything to the contrary herein, Powerex shall have no warranty obligations with respect to Products:

- (i) that have not been installed in accordance with Powerex's written specifications and instructions;
- (ii) that have not been maintained in accordance with Powerex's written instructions;
- (iii) that have been materially modified without the prior written approval of Powerex; or
- (iv) that experience failures resulting from operation, either intentional or otherwise, in excess of rated capacities or in an otherwise improper manner.

(f) The warranty provided herein shall not apply to: (i) any defects arising from corrosion, abrasion, use of insoluble lubricants, or negligent attendance to or faulty operation of the Products; (ii) ordinary wear and tear of the Products; or (iii) defects arising from abnormal conditions of temperature, dirt or corrosive matter; (iv) any OEM component which is shipped by Powerex with the original manufacturer's warranty, which shall be the sole applicable warranty for such component.

Limitation of Liability. TO THE EXTENT ALLOWABLE UNDER APPLICABLE LAW, NOTWITHSTANDING ANYTHING TO THE CONTRARY HEREIN, UNDER NO CIRCUMSTANCES SHALL POWEREX BE LIABLE FOR ANY INCIDENTAL, CONSEQUENTIAL, PUNITIVE, SPECULATIVE OR INDIRECT LOSSES OR DAMAGES WHATSOEVER ARISING OUT OF OR IN ANY WAY RELATED TO ANY OF THE PRODUCTS OR GOODS SOLD OR AGREED TO BE SOLD BY POWEREX TO BUYER. TO THE EXTENT ALLOWABLE UNDER APPLICABLE LAW, POWEREX'S LIABILITY IN ALL EVENTS IS LIMITED TO, AND SHALL NOT EXCEED, THE PURCHASE PRICE PAID.

Warranty Disclaimer. Powerex has made a diligent effort to illustrate and describe the Products in this literature accurately; however, such illustrations and descriptions are for the sole purpose of identification, and do not express or imply a warranty that the Products are merchantable, or fit for a particular purpose, or that the Products will necessarily conform to the illustrations or descriptions.

Product Suitability. Many jurisdictions have codes and regulations governing sales, construction, installation, and/or use of Products for certain purposes, which may vary from those in neighboring areas. While Powerex attempts to assure that its Products comply with such codes, it cannot guarantee compliance, and cannot be responsible for how the product is installed or used. Before purchase and use of a Product, please review the Product applications, and national and local codes and regulations, and be sure that the Product, installation, and use will comply with them.

Claims. Claims pertaining to the Products, with the exception of warranty claims, must be filed with Powerex within 6 months of the invoice date, or they will not be honored. Prices, discounts, and terms are subject to change without notice or as stipulated in specific Product quotations. All agreements are contingent upon strikes, accidents, or other causes beyond our control. All shipments are carefully inspected and counted before leaving the factory. Please inspect carefully any receipt of Products noting any discrepancy or damage on the carrier's freight bill at the time of delivery. Discrepancies or damage which obviously occurred in transit are the carrier's responsibility and related claims should be made promptly directly to the carrier. Returned Products will not be accepted without prior written authorization by Powerex and deductions from invoices for shortage or damage claims will not be allowed. **UNLESS OTHERWISE AGREED TO IN WRITING, THESE TERMS AND CONDITIONS WILL CONTROL IN ANY TRANSACTION WITH POWEREX** any different or conflicting terms as may appear on any order form now or later submitted by the buyer. All orders are subject to acceptance by Powerex.