

## Climate Control Duplex

**Please read and save these instructions. Read carefully before attempting to assemble, install, operate or maintain the product described. Protect yourself and others by observing all safety information. Failure to comply with instructions could result in personal injury and/or property damage! Retain instructions for future reference.**

### Description

The AD Series Powerex Duplex Air Compressors have been designed, broken-in and tested to meet the most demanding specifications for low oil carryover and long life in the pneumatic climate control industry.

The units consist of two equally rated motor-compressor assemblies mounted on a single ASME tank. The compressor motors are NEMA Class B design. The AD Series Compressors are ideal for instrumentation systems requiring an alternate compressor for standby or overload capacity. See Table 1 for motor sizes and air delivery capacities available.

Compressor assemblies are available with or without a factory mounted basic or deluxe alternator/motor starter package. An unloading feature is included on all compressors to provide loadless starting. Models with an alternator are prewired and ready for operation. Internal wiring allows for shutdown of either compressor for repair while the other compressor is running.

An alternating type operation is desirable for many reasons. When a duplex air compressor is alternated, the temperature of both units is kept above the ambient dew point to minimize moisture deterioration and corrosion. Also, the reduction in on-time provides a lower average head temperature with reduced oil entrainment potential and improves the motor life by holding down the average heat rise.

All units are run through a factory break-in and are tested for air delivery, leakage and power consumption. Tank-mounted units are shipped with a proper fill of compressor oil in the crankcase and are furnished with an intake filter with a replaceable cartridge. This filter is designed to remove contaminants in the inlet air, as well as provide a quiet operation.

All models have conveniently located oil drain and filler ports to facilitate routine maintenance. Tanks have a condensate drain valve with an extension for easy access. Mounting bases are slotted to allow tension adjustments to aid in maintaining proper compressor and motor alignment while adjusting tension.

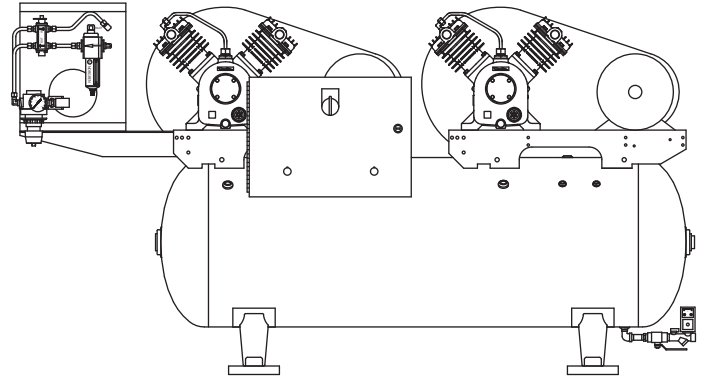

### Specifications

Product	AD Series Powerex Duplex Air Compressors	
Performance Specifications	See Page 2	
Lubrication	Splash Lubrication System (3/4 HP - 10 HP Models)	
Operating Voltages	1Ø	115 - 280 / 230 Volts, 60 Hz
	3Ø	280 - 230 / 460 Volts, 60 Hz
Compression Cycle	Single-Stage (3/4 HP - 10 HP Models)	
Motor Overload Protection	1Ø	Built-in Thermal Overload (Standard)
	3Ø	Magnetic Starter and Three Thermal Overload Heaters (Optional)
Pressure Settings	<i>Lead</i> Cut-In: Factory Set at Approximately 70 psig (490 kPa) Cut-Out: Factory Set at Approximately 90 psig (630 kPa)  <i>Lag</i> Cut-In: Factory Set at Approximately 60 psig (420 kPa) Cut-Out: Factory Set at Approximately 80 psig (560 kPa)	
Overpressure Protection	ASME Safety Valve Factory Set and Sealed at Approximately 115 psig (805 kPa)	
Outlet Air Connections	3/4 inch NPT (30, 60, and 80 Gallon Tanks) 1 inch NPT (120 and 200 Gallon Tanks)	
Tank Sizes	30 Gallon to 200 Gallon	
California Ordinance 462 (L) (2)	Meets Requirements of this Ordinance	
Tank Isolation	Standard All Units	

*The performance specifications are nominal and conform to acceptable industry standards. For application at conditions beyond these specifications, consult the local Powerex office. Powerex shall not be liable for damages resulting from misapplication or misuse of its products.*

## Performance Specifications

Base Model	Motor Rating		Compressor RPM	Compressor Capacity ACFM @ 80 psig		
	HP	RPM		100% Runtime	50% Runtime	33% Runtime
AD-107	0.75	1725	980	2.1	1.07	0.71
AD-007	0.75	1725	980	2.1	1.07	0.71
AD-110	1.0	1725	1120	3.5	1.74	1.15
AD-010	1.0	1750	1120	3.5	1.74	1.15
AD-015	1.5	1760	860	4.6	2.3	1.5
AD-020	2.0	1755	1250	6.9	3.4	2.3
AD-030	3.0	1725	1050	10.3	5.2	3.4
AD-050	5.0	1750	1150	19.0	9.5	6.3
AD-075	7.5	1750	950	28.6	14.3	9.5
AD-100	10.0	1765	880	37.8	18.9	12.5

**NOTE:** 0.75 HP pumps must be used under altitudes of 5000 feet. Above 5000 feet, 1 HP pumps must be used.

## Safety Guidelines

This manual contains information that is very important to know and understand. This information is provided for SAFETY and to PREVENT EQUIPMENT PROBLEMS. To help recognize this information, observe the following symbols.

### **⚠ DANGER**

*Danger indicates an imminently hazardous situation which, if not avoided, WILL result in death or serious injury.*

### **⚠ WARNING**

*Warning indicates a potentially hazardous situation which, if not avoided, COULD result in death or serious injury.*

### **⚠ CAUTION**

*Caution indicates a potentially minor or moderate injury.*

### **NOTICE**

*Notice indicates important information, that if not followed, may cause damage to equipment.*

**NOTE:** Information that requires special attention.

### **CALIFORNIA PROPOSITION 65**

### **⚠ WARNING**

*This product or its power cord may contain chemicals known to the State of California to cause cancer and birth defects or other reproductive harm. Wash hands after handling.*

## Installation

### **MOUNTED AND CONNECTED OPTIONS**

#### **Deluxe Alternator Package**

All Powerex Duplex air compressors may be ordered with an optional deluxe alternator package consisting of two magnetic motor starts with thermal overloads, an alternating coil, a 120 VAC control transformer and a three-position selector switch. The three-position switch allows for automatic alternation or only running one unit at a time. This will allow for service on one unit while other unit is running.

#### **Basic Alternator Package**

All Powerex duplex air compressors may be ordered with a simplified line voltage basic alternator package. The basic alternator package consists of an alternating coil and two magnetic motor starters. Motor starters are selected and wired for intended input voltage and are furnished with properly sized overload heaters.

#### **Automatic Tank Drain**

Powerex air compressors may be ordered with a manual or electric type automatic tank drain. A manual drain attachment is furnished with each unit.

#### **Vibration Dampening Pads**

Waffle type design vibration pads are provided as standard equipment.

## Operation

Factory calibrated DPST pressure switches provide lead and lag settings. When using an alternator-starter package, the lead switch energizes the alternator and the alternator activates the compressor that was on standby during the previous cycle. If the demand exceeds the capacity of one compressor, the lag switch will cause both compressors to run simultaneously. Upon failure of either compressor, the lag switch will continue to activate the workable compressor.

Single-phase motors (3/4 HP & 1 HP) have built-in overload protection with manual reset. Three-phase motors require a magnetic starter and three overload heaters. Heaters are included with three-phase compressors that have a factory mounted alternator.

**NOTE:** All pump models operate turning clockwise opposite the motor shaft / pump flywheel / belt guard side of the unit. Improper rotation will cause oil to spray out of the breather vent opening.

## Operation (Continued)

### LUBRICATION

Check lubricating oil level at gauge. Refill if necessary. See Figure 1.

Change oil according to maintenance schedule. Before draining oil, remove oil supply cap and loosen oil drain cap to release trapped air. Use Mobil Rarus 427® or Mobil DTE heavy oils.

### ⚠ WARNING

Dispose of oil in accordance with state or local codes.

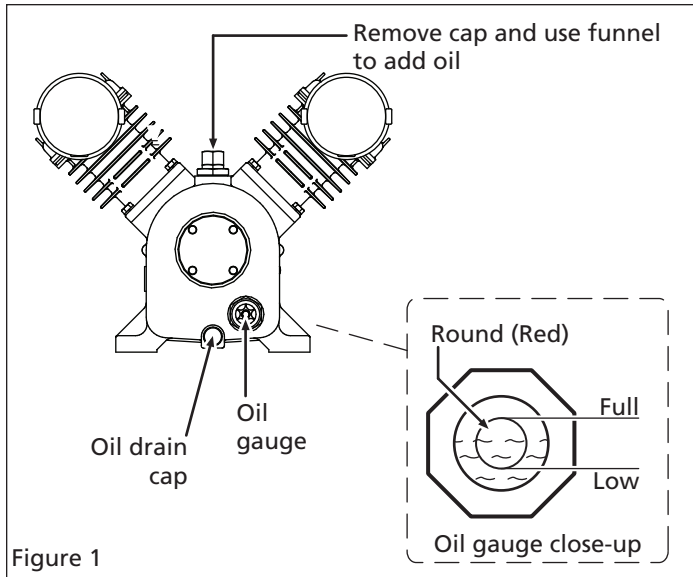

Figure 1

### AUTO E-DRAIN ASSEMBLY (See Figure 2)

**NOTE:** The automatic E-drain is assembled to tank.

1. Plug E-drain into 115V power outlet supply.
2. Adjust times accordingly.

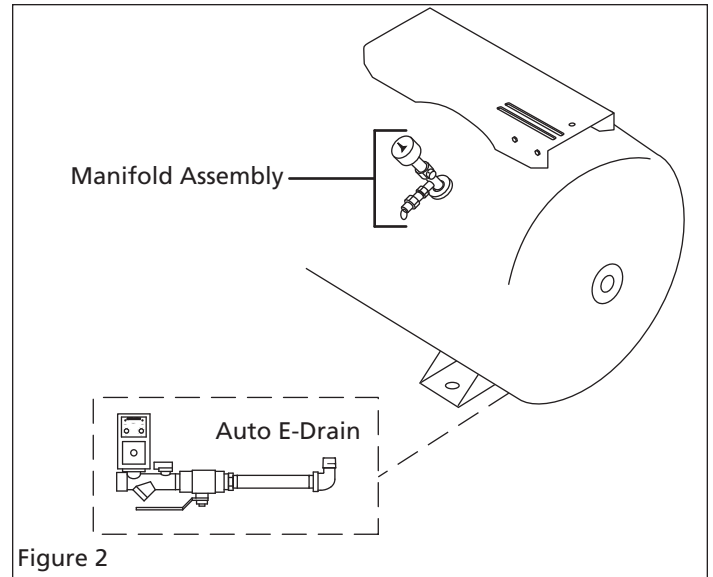

Figure 2

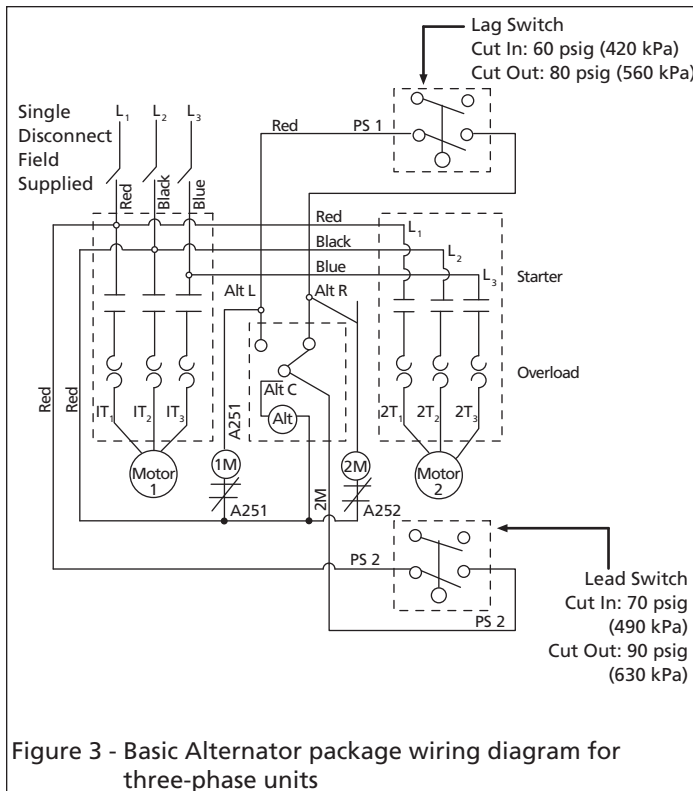

Figure 3 - Basic Alternator package wiring diagram for three-phase units

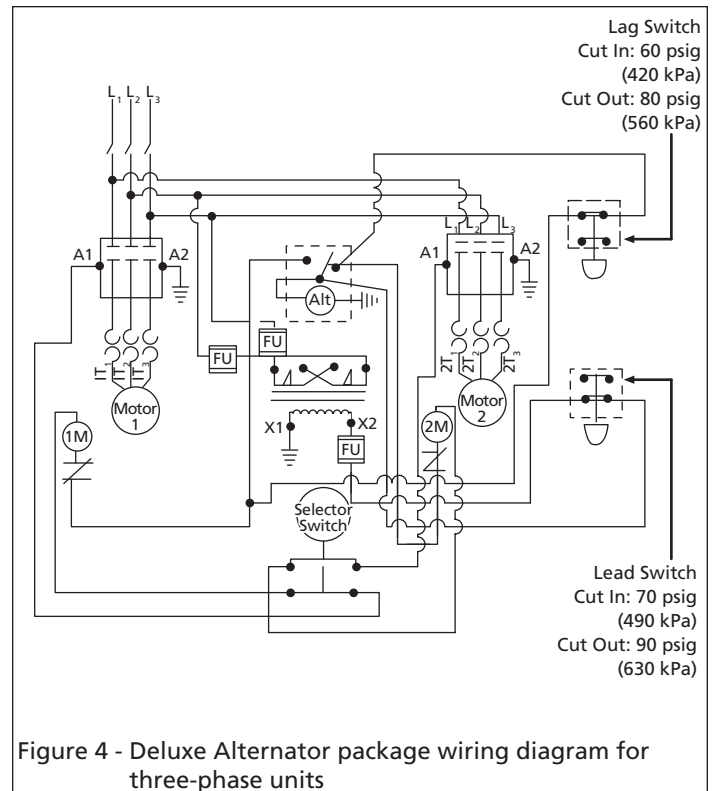
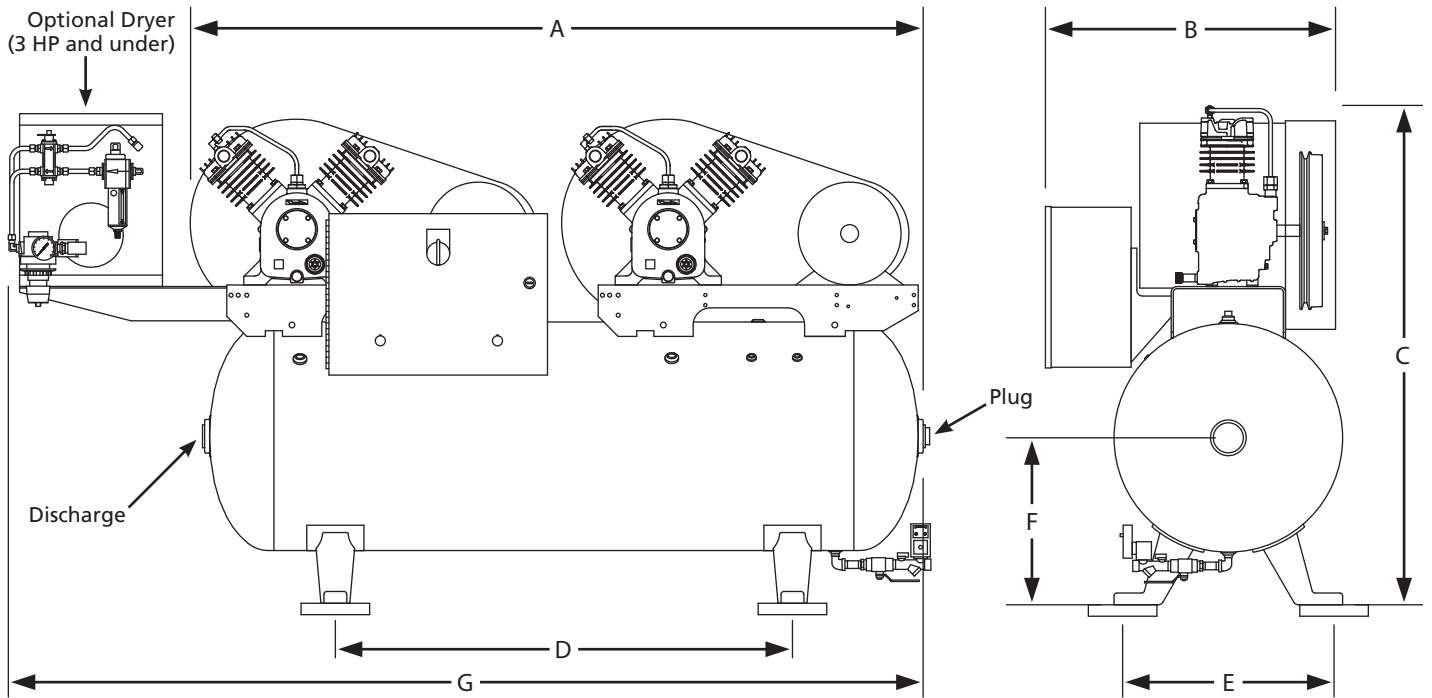

Figure 4 - Deluxe Alternator package wiring diagram for three-phase units

**Unit Dimensions (inches \*) and Shipping Weights (pounds \*)**



Base Model	A	B		C	D	E	F	G	Unit Weight**	
		with Alternator	without Alternator						with Alternator	without Alternator
AD-107-1XX	41.50	24.00	17.75	36.50	18.00	15.75	12.25	57.25	298	278
AD-007-1XX	41.50	24.00	17.75	36.50	18.00	15.75	12.25	57.25	298	278
AD-107-3XX	63.60	27.00	20.00	42.50	40.00	18.00	14.60	70.00	463	443
AD-007-3XX	63.60	27.00	20.00	42.50	40.00	18.00	14.60	70.00	463	443
AD-110-1XX	41.50	24.00	17.75	36.50	18.00	15.75	12.25	57.25	297	277
AD-010-1XX	41.50	24.00	17.75	36.50	18.00	15.75	12.25	57.25	297	277
AD-110-3XX	63.60	25.00	20.00	43.30	40.00	18.00	14.60	69.80	462	442
AD-010-3XX	63.60	25.00	20.00	43.30	40.00	18.00	14.60	69.80	462	442
AD-015-1XX	41.50	25.80	17.75	38.75	18.00	15.75	12.25	57.10	322	302
AD-015-3XX	63.75	25.00	20.00	43.30	40.00	18.00	14.60	69.80	487	467
AD-020-3XX	63.75	26.00	20.00	43.60	40.00	18.00	14.60	80.60	512	492
AD-030-3XX	64.10	25.4	20.00	43.70	40.00	18.00	14.60	80.25	715	695
AD-030-4XX	70.75	28.10	24.00	48.20	42.00	18.00	16.80	81.75	845	825
AD-050-4XX	71.60	29.00	24.00	50.50	42.00	18.00	16.80	--	988	968
AD-050-5XX	82.60	33.25	30.50	56.60	42.00	22.00	18.75	--	1213	1193
AD-075-4XX	71.58	29.57	24.80	54.25	42.00	18.00	16.80	--	1113	1088
AD-075-5XX	82.62	33.25	30.00	59.40	42.00	22.00	18.75	--	1338	1313
AD-100-5XX	82.62	33.25	30.00	59.40	42.00	22.00	18.75	--	1553	1528

\* inches x 2.54 = centimeters; pounds x 0.454 = kilograms

\*\* Add 60.0 pounds for units equipped with a factory mounted air dryer

## Maintenance Schedule

Item	Action needed	Operating Hours								Remarks
		Daily	500	1500	2500	5000	10,000	15,000	20,000	
Tank	Drain moisture	●								Drain tank daily
Inlet air filter	Inspect, Replace		●		▲					Every 2500 hours or less
Pump flywheel	Clean					●	●	●	●	
Compressor fins	Clean				●					Every 2500 hours or less
Oil change	Replace			▲						Every 1500 hours
Compression rings	Replace							▲		
Check oil	Inspect	●								
V-belt	Inspect, Replace				●	▲	▲	▲	▲	See Note 3
Pressure switch	Confirm operation				●				●	
Magnetic starter	Inspect						●		●	Replace if contact points deteriorated
Safety valve	Confirm operation				●					Every 2500 hours or 6 months
Pressure gauge	Inspect				●					Every 2500 hours or less

- Inspect
- ▲ Replace

**NOTES:**

1. Inspect and perform maintenance periodically according to maintenance schedule.
2. The maintenance schedule relates to the normal operating conditions. If the circumstances and load condition are adverse, shorten the cycle time and do maintenance accordingly.
3. The tension of the V-belt should be adjusted during initial start up and inspected every 1,500 hours afterwards. Proper belt tension for 3/4 to 3 HP units is 2-3 lbs./0.5 inch deflection; for 5 to 10 Hp units, 4-6 lbs./0.5 inch deflection.

## Oil Capacity Chart

Model	HP	Oil Capacity	
		0 to High (liters)	Low to High (liters)
LPS007	0.75	0.44	0.12
LPS010A	1.0	0.44	0.12
LPS020A	1.5/2	0.44	0.12
LPS030A	3	0.70	0.20
LPS050A	5	1.03	0.35
LPS075A	7.5	1.70	0.45
LPS100A	10	1.70	0.45





# Climate Control Duplex

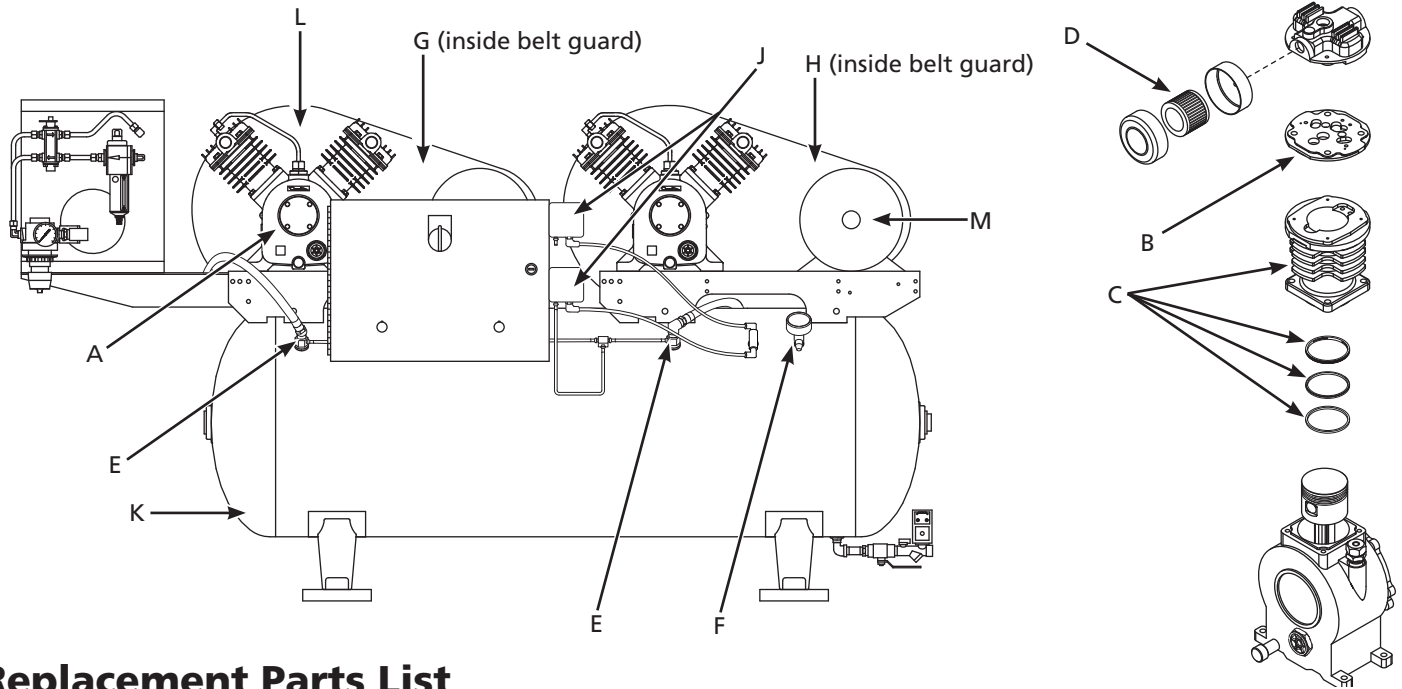

## Replacement Parts List

Item	Description		Quantity Required	Part Number	
A	<b>PUMP AND FLYWHEEL:</b> <u>Motor HP</u>	3/4	2	A-007-6001AP	
		1	2	A-010-6001AP	
		1-1/2, 2	2	A-020-6001AP	
		3	2	A-030-6001AP	
		5	2	A-050-6001AP	
		7-1/2	2	A-075-6001AP	
		10	2	A-100-6001AP	
B	<b>VALVE KIT:</b> Includes valve plate, spacer and head gasket <u>Motor HP</u>	3/4, 1	2	A-010-6002AP	
		1-1/2, 2	2	A-010-6002AP	
		3	4	A-030-6002AP	
		5	4	A-050-6002AP	
		7-1/2	4	A-075-6002AP	
		10	6	A-075-6002AP	
C	<b>RING/CYLINDER KIT:</b> Includes all compression rings, oil control rings, cylinder, gasket and sealant <u>Motor HP</u>	3/4, 1	2	A-010-6004AP	
		1-1/2, 2	2	A-010-6004AP	
		3	4	A-030-6004AP	
		5	4	A-050-6004AP	
		7-1/2	4	A-075-6004AP	
		10	6	A-075-6004AP	
D	<b>INTAKE FILTER ELEMENT:</b> <u>Motor HP</u>	3/4, 1	2	A-010-6023AP	
		1-1/2, 2	2	A-010-6023NP	
		3	4	A-010-6023NP	
		5	4	A-010-6023NP	
		7-1/2	4	A-010-6023NP	
		10	4	A-010-6023NP	
E	<b>IN-TANK CHECK VALVE:</b> <u>Motor HP</u>	<b>Size</b>			
		3/4 Through 3	1/2 inch MPT x 1/2 inch FPT	2	A-010-6008
		5 Through 10	3/4 inch MPT x 3/4 inch FPT	2	A-075-6008
F	<b>SAFETY RELIEF VALVE:</b> Set at approximately 115 psig (805 kPa)	3/4 Through 5 HP Models	1	A-050-6009	
		7-1/2 Through 10 HP Models	1	A-200-6009	



## Replacement Parts List (Continued)

Item	Description	Quantity Required	Part Number	
<b>G</b>	<b>BELT:</b>			
	<u>Motor HP</u>	<u>Size</u>		
	3/4	A-42	2	A-010-6006AP
	1	A-43	2	A-010-6006AP
	1-1/2	AX-46	2	A-015-6006AP
	2	A-59	2	A-020-6006AP
	3	B-62	2	A-030-6006AP
	5	B-67	2	A-050-6006AP
	7-1/2	B-69	4	A-075-6036AP
	7-1/2	B-75	4	A-075-6056AP
10	A-80	4	A-100-6006AP	
<b>H</b>	<b>MOTOR PULLEY:</b>			
	<u>Motor HP</u>	<u>Type</u>		
	3/4	1A-5.7 inch P.D., 5/8 inch Bore	2	A-007-6007AP
	1 (1Ø)	1A-5.7 inch P.D., 5/8 inch Bore	2	A-110-6007AP
	1 (3Ø)	1A-6.0 inch P.D., 7/8 inch Bore	2	A-010-6007AP
	1-1/2	1A-5.5 inch P.D., 7/8 inch Bore	2	A-015-6007AP
	2	1BK-8.0 inch P.D., 7/8 inch Bore	2	A-020-6007AP
	3	1B-8.0 inch P.D., 1-1/8 inch Bore	2	A-030-6007AP
	5	1B-9.4 inch P.D., 1-1/8 inch Bore	2	A-050-6007AP
	7-1/2	2B-8.6 inch P.D., 1-3/8 inch Bore	2	A-100-6007AP
10	2B-8.6 inch P.D., 1-3/8 inch Bore	2	A-100-6007AP	
<b>J</b>	<b>PRESSURE ELECTRIC SWITCHES:</b> (For all models)			
	<b>Lead Switch:</b> Set at approximately 70 psig (490 kPa) cut-in and 90 psig (630 kPa) cut-out	1	A-100-6010	
	<b>Lag Switch:</b> Set at approximately 60 psig (420 kPa) cut-in and 80 psig (560kPa) cut-out	1	A-100-6011	
<b>K</b>	<b>TANK:</b>			
	<u>Motor HP</u>	<u>Tank Size</u>		
	3/4 Through 1-1/2	30 gallon	1	A-015-6030AP
	3/4 Through 1-1/2	80 gallon	1	A-015-6080AP
	2 & 3	80 gallon	1	A-030-6080AP
	2 & 3	120 gallon	1	A-030-6120AP
5 & 7-1/2	120 gallon	1	A-075-6120AP	
5 Through 10	200 gallon	1	A-100-6200AP	
<b>L</b>	<b>BELT GUARD:</b>			
	<u>Motor HP</u>			
	3/4 Through 1-1/2		2	A-015-6012AP
	2		2	A-020-6012AP
	3		2	A-030-6012AP
	5		2	A-075-6012AP
	7-1/2 (120 Gal)		2	A-075-6012AP
7-1/2 (200 Gal)		2	A-075-6022AP	
10		2	A-100-6012AP	
<b>M</b>	<b>MOTOR:</b>			
	<u>Motor HP</u>			
	3/4 (1Ø)		2	MC301510AV
	3/4 (3Ø)		2	MC301511AV
	1 (1Ø)		2	MC022371AV
	1 (3Ø)		2	MC301512AV
	1-1/2 (1Ø)		2	MC022320AV
	1-1/2 (3Ø)		2	MC301513AV
	2 (1Ø)		2	MC022317AV
	2 (3Ø)		2	MC303300AV
	3		2	MC303301AV
	5		2	MC303303AV
7-1/2		2	MC303308AV	
10		2	MC303310AV	



## **Powerex Limited Warranty – Applicable to Non-OEM Customers in the U.S. & Canada Only**

### **Warranty and Remedies.**

**(a) General.** Powerex warrants each Compressor System, Vacuum System, Vacuum Pump, Compressor Air-End, or Powerex branded Accessory (collectively “Products”, individually each a “Product”) to be free from defects in material and workmanship (“Defects”) at the date of shipment. This warranty shall apply only to Products that are purchased and used in the United States of America and in Canada. EXCEPT AS SET FORTH BELOW, NO OTHER WARRANTY, WHETHER EXPRESS OR IMPLIED, INCLUDING ANY WARRANTY OF MERCHANTABILITY OR FITNESS FOR A PARTICULAR PURPOSE, SHALL EXIST IN CONNECTION WITH THE SALE OR USE OF SUCH PRODUCTS. TO THE EXTENT PERMITTED BY LAW, ANY AND ALL IMPLIED WARRANTIES ARE EXCLUDED. All warranty claims must be made in writing and delivered to Powerex in accordance with the procedures set forth on its website (www.powerexinc.com), or such claim shall be barred. Upon timely receipt of a warranty claim, Powerex shall inspect the Product claimed to have a Defect, and Powerex shall repair, or, at its option, replace, free of charge, any Product which it determines to have had a Defect; provided, however, that if circumstances are such as to preclude the remedying of Defect by repair or replacement, Powerex shall, upon return of the Product, refund to buyer any part of the purchase price of such Products paid to Powerex. Freight for returning Products to Powerex for inspection shall be paid by buyer. The warranties and remedies herein are the sole and exclusive remedy for any breach of warranty or for any other claim based on any Defect, or non-performance of the Products, whether based upon contract, warranty or negligence.

**(b) (i) Standard Period of Warranty – Parts and Labor** - The purchase of any system includes our standard warranty. Powerex warrants and represents all Products shall be free from Defects for the first eighteen (18) months from the date of shipment by Powerex, or twelve (12) months from the documented date of startup, or five thousand (5,000) hours of use, whichever occurs first. During such warranty period, Powerex shall be fully liable for all Defects in the Products (the “Product Defects”), i.e., all costs of repair or replacement, which may include “in and out” charges, so long as the Products are located in the United States or Canada, and the Products are reasonably located and accessible by service personnel for removal. “In and out” charges include the costs of removing a Product from buyer’s equipment for repair or replacement.

**(ii) Premium Period of Warranty – Parts and Labor** - In order to be eligible for premium warranty coverage, a premium warranty for each system must be purchased when order is placed. Powerex warrants and represents all Products shall be free from Defects for the first thirty (30) months from the date of shipment by Powerex, or twenty-four (24) months from the documented date of startup, or seven thousand five hundred (7,500) hours of use, whichever occurs first. During such warranty period, Powerex shall be fully liable for all Defects in the Products (the “Product Defects”), i.e., all costs of repair or replacement, which may include “in and out” charges, so long as the Products are located in the United States or Canada, and the Products are reasonably located and accessible by service personnel for removal. “In and out” charges include the costs of removing a Product from buyer’s equipment for repair or replacement.

**(c) Additional Period of Warranty – Parts Only (No Labor).** In addition to the above, Powerex warrants each Powerex branded Compressor Air- End and Vacuum Pump shall be free of Defects for a period of forty-two (42) months from the date of shipment by Powerex, or thirty-six (36) months from the documented date of startup, or ten thousand (10,000) hours of use, whichever occurs first. Supplier’s repair or replacement of any Product shall not extend the period of any warranty of any Product. This warranty applies to the exchange of part(s) found to be defective by an Authorized Powerex Service Representative only.

**(d) Replacement Pumps – Parts Only (No Labor).** For any replacement Air-End or Vacuum Pumps installed on a Powerex manufactured system or unit after any initial warranty period has expired or where another warranty does not apply for any reason, Powerex warrants that the Air-End or Vacuum Pumps shall be free of Defects for a period of thirty-six (36) months from the date of shipment by Powerex or ten thousand (10,000) hours of use, whichever comes first. For any replacement Air-End or Vacuum Pumps installed on a system that was not manufactured by Powerex after any initial warranty period has expired or where another warranty does not apply for any reason, Powerex warrants that the Air-End or Vacuum Pumps shall be free of Defects for the first twelve (12) months from the date of shipment by Powerex. Supplier’s repair or replacement of any Product shall not extend the period of any warranty of any Product. This warranty applies to the exchange of part(s) found to be defective by an Authorized Powerex Service Representative only.

**(e) Replacement Motors – Parts Only (No Labor).** For any replacement motor installed on a Powerex manufactured system or unit after any initial warranty period has expired or where another warranty does not apply for any reason, Powerex warrants that the replacement motor shall be free of Defects for the first twelve (12) months from the date of shipment by Powerex. For any replacement motor installed on a system or unit that was not manufactured by Powerex after any initial warranty period has expired or where another warranty does not apply for any reason, Powerex warrants that the replacement motor shall be free of Defects for the first ninety (90) days from the date of shipment by Powerex. Supplier’s repair or replacement of any Product shall not extend the period of any warranty of any Product. This warranty applies to the exchange of part(s) found to be defective by an Authorized Powerex Service Representative only.

**(f) Replacement Parts – Parts Only (No Labor).** For other replacement parts besides motors, Air-End or Vacuum Pumps installed on a Powerex manufactured system or unit after any initial warranty period has expired or where another warranty does not apply for any reason, Powerex warrants that such replacement parts will be free from Defects for the first twelve (12) months from the date of shipment by Powerex. For other replacement parts besides motors, Air-End or Vacuum Pumps installed on a system or unit that was not manufactured by Powerex after any initial warranty period has expired or where another warranty does not apply for any reason, Powerex makes no warranties. Supplier’s repair or replacement of any Product shall not extend the period of any warranty of any Product. This warranty applies to the exchange of part(s) found to be defective by an Authorized Powerex Service Representative only.

**(g) Coverage.** The warranty provided herein applies to Powerex manufactured units or systems only.

**(h) Exceptions.** Notwithstanding anything to the contrary herein, Powerex shall have no warranty obligations with respect to Products:

- (i) that have not been installed in accordance with Powerex’s written specifications and instructions;
- (ii) that have not been maintained in accordance with Powerex’s written instructions;
- (iii) that have been materially modified without the prior written approval of Powerex; or
- (iv) that experience failures resulting from operation, either intentional or otherwise, in excess of rated capacities or in an otherwise improper manner.

## Climate Control Duplex

---

(i) The warranty provided herein shall not apply to:

- (i) any defects arising from corrosion, abrasion, use of insoluble lubricants, or negligent attendance to or faulty operation of the Products;
- (ii) ordinary wear and tear of the Products;
- (iii) defects arising from abnormal conditions of temperature, dirt or corrosive matter; or
- (iv) any OEM component which is shipped by Powerex with the original manufacturer's warranty, which shall be the sole applicable warranty for such component.

**Limitation of Liability.** NOTWITHSTANDING ANYTHING TO THE CONTRARY HEREIN, TO THE EXTENT ALLOWABLE UNDER APPLICABLE LAW, UNDER NO CIRCUMSTANCES SHALL POWEREX BE LIABLE FOR ANY INCIDENTAL, CONSEQUENTIAL, PUNITIVE, SPECULATIVE OR INDIRECT LOSSES OR DAMAGES WHATSOEVER ARISING OUT OF OR IN ANY WAY RELATED TO ANY OF THE PRODUCTS OR GOODS SOLD OR AGREED TO BE SOLD BY POWEREX TO BUYER. TO THE EXTENT ALLOWABLE UNDER APPLICABLE LAW, POWEREX'S LIABILITY IN ALL EVENTS IS LIMITED TO, AND SHALL NOT EXCEED, THE PURCHASE PRICE PAID.

**Warranty Disclaimer.** Powerex has made a diligent effort to illustrate and describe the Products in its literature, including its Price Book, accurately; however, such illustrations and descriptions are for the sole purpose of identification, and do not express or imply a warranty that the Products are merchantable, or fit for a particular purpose, or that the Products will necessarily conform to the illustrations or descriptions.

**Product Suitability.** Many jurisdictions have codes and regulations governing sales, construction, installation, and/or use of Products for certain purposes, which may vary from those in neighboring areas. While Powerex attempts to assure that its Products comply with such codes, it cannot guarantee compliance, and cannot be responsible for how the product is installed or used. Before purchase and use of a Product, please review the Product applications, and national and local codes and regulations, and be sure that the Product, installation, and use will comply with them.

**Claims.** Any non-warranty claims pertaining to the Products must be filed with Powerex within 6 months of the invoice date, or they will not be honored. Prices, discounts, and terms are subject to change without notice or as stipulated in specific Product quotations. Powerex shall not be liable for any delay or failure arising out of acts of the public enemy, fire, flood, or any disaster, labor trouble, riot or disorder, delay in the supply of materials or any other cause, whether similar or dissimilar, beyond the control of Company. All shipments are carefully inspected and counted before leaving the factory. Please inspect carefully any receipt of Products noting any discrepancy or damage on the carrier's freight bill at the time of delivery. Discrepancies or damage which obviously occurred in transit are the carrier's responsibility and related claims should be made promptly directly to the carrier. Returned Products will not be accepted without prior written authorization by Powerex and deductions from invoices for shortage or damage claims will not be allowed. **UNLESS OTHERWISE AGREED TO IN WRITING, THE TERMS AND CONDITIONS CONTAINED IN THIS LIMITED WARRANTY WILL CONTROL IN ANY TRANSACTION WITH POWEREX.** Any different or conflicting terms as may appear on any order form now or later submitted by the buyer will not control. All orders are subject to acceptance by Powerex.