



High Pressure Scroll Tankmount/Basemount Air Compressors

Please read and save these instructions. Read carefully before attempting to assemble, install, operate or maintain the product described. Protect yourself and others by observing all safety information. Failure to comply with instructions could result in personal injury and/or property damage! Retain instructions for future reference.

Descriptions

GENERAL

The Powerex Oilless Rotary Scroll Air Compressor has advanced scroll compressor technology through the development of a completely oilless unit. The Powerex Scroll Compressor offers a dynamically balanced air end which insures vibration-free operation. The rotary design permits a continuous 100% duty cycle. No oil separation, oil filtration, or inlet valves are required on the Powerex Scroll unit.

COMPRESSION CYCLE

The Powerex oilless rotary scroll air compressor is based on the theory of scroll compression. A scroll is a free standing, intricate spiral bounded on one side by a solid, flat plane or base. A scroll set, the basic compression element of a scroll compressor, is made up of two identical spirals which form right and left hand parts. One of these scroll components is indexed or phased 180° with respect to the other so the scrolls can mesh. Crescent-shaped gas pockets are formed and bounded by the spirals and the base plate of both scrolls. As the moving scroll is orbited around the fixed scroll, the pockets formed by the meshed scrolls follow the spiral toward the center and diminish in size. The moving scroll is prevented from rotating during this process so the 180° phase relationship of the scrolls is maintained. The compressor's inlet is at the outer boundary of the scrolls. The compressed gas is discharged through the outlet at the center of the fixed scroll so no valves are needed.

TIP SEAL

The tip seal on the scroll compressor is self-lubricated and allows the unit to operate efficiently without oil and expensive filtration. The tip seal should be replaced every 5,000 hours of operation.

BEARINGS

The bearings on the scroll compressor are regreaseable to allow extended compressor life. Service should be performed every 5,000 hours of operation.

DRY TYPE INLET FILTER (P/N IP032901AV)

Order P/N IP032901AV for both the 3 HP and 5HP units. Change every 2,500 hours or more often in dirty locations.

HOURLY METER

The hourmeter on the scroll compressor indicates the actual number of hours the unit has been in operation. The hourmeter is also used to determine maintenance and service timing.

An hourmeter must be installed with every Scroll compressor.

CONDENSATE DRAIN VALVE

A condensate drain valve must be installed on any tank used to allow removal of the liquid which will collect during compressor operation.

NOTICE

Drain liquid from tank daily.

⚠ DANGER

Breathable Air Warning

This compressor/pump is NOT equipped and should NOT be used "as is" to supply breathing quality air. For any application of air for human consumption, you must fit the air compressor/pump with suitable in-line safety and alarm equipment. This additional equipment is necessary to properly filter and purify the air to meet minimal specifications for Grade D breathing as described in Compressed Gas Association Commodity Specification G 7.1 - 1966, OSHA 29 CFR 1910. 134, and/or Canadian Standards Associations (CSA).

DISCLAIMER OF WARRANTIES IN THE EVENT THE COMPRESSOR IS USED FOR THE PURPOSE OF BREATHING AIR APPLICATION AND PROPER IN-LINE SAFETY AND ALARM EQUIPMENT IS NOT SIMULTANEOUSLY USED, EXISTING WARRANTIES ARE VOIDED, AND POWEREX DISCLAIMS ANY LIABILITY WHATSOEVER FOR ANY LOSS, PERSONAL INJURY OR DAMAGE.

Scroll Air Compressors Tankmount/Basemount

Installation

RECEIVING THE UNIT

Immediately upon receipt of the scroll compressor, the unit should be inspected for any damage which may have occurred in shipment.

The compressor nameplate should be checked to see if the unit is the correct model and voltage as ordered.

APPLICATION

When the scroll compressor is to be used in applications other than the compressing of atmospheric air, please contact a Powerex representative for engineering and warranty information at 1-888-769-7979.

INSTALLATION SITE

1. The scroll compressor must be located in a clean, well lit and well ventilated area.
2. The area should be free of excessive dust, toxic or flammable gases and moisture.
3. Never install the compressor where the ambient temperature is higher than 104° F or where humidity is high.
4. Clearance must allow for safe, effective inspection and maintenance.

Minimum Clearances	
Above	24"
Drive belt side	12"
Other sides	20"

5. If necessary, use metal shims or leveling pads to level the compressor. Never use wood to shim the compressor.

VENTILATION

1. If the scroll compressor is located in a totally enclosed room, an exhaust fan with access to outside air must be installed.
2. Never restrict the cooling fan exhaust air.
3. Never locate the compressor where hot exhaust air from other heat generating units may be pulled into the unit.

WIRING

Refer to the general product manual. All electrical hook-ups must be performed by a qualified electrician. Installations must be in accordance with local and national electrical codes. Use solderless terminals to connect the electric power source.

PIPING

- Refer to the general product manual.
1. Make sure the piping is lined up without being strained or twisted when assembling the piping for the scroll compressor.
 2. Appropriate expansion loops or bends should be installed at the compressor to avoid stresses caused by changes in hot and cold conditions.
 3. Piping supports should be anchored separately from the compressor to reduce noise and vibration.
 4. Never use any piping smaller than the compressor connection.
 5. Use flexible hose to connect the outlet of the compressor to the piping so that the vibration of the compressor does not transfer to the piping.

SAFETY VALVES

Tank mounted compressors are shipped from the factory with safety valves installed in the tank manifold. The flow capacity of the safety valve is equal to or greater than the capacity of the compressor.

1. The pressure setting of the safety valve must be no higher than the maximum working pressure of the tank.
2. Safety valves should be placed ahead of any possible blockage point in the system, i.e. shutoff valve.
3. Avoid connecting the safety valve with any tubing or piping.
4. Manually operate the safety valve every six months to avoid sticking or freezing.

Operation

BEFORE START UP

1. Make sure all safety warnings, labels and instructions have been read and understood before continuing.
2. Remove any shipping materials, brackets, etc.
3. Confirm that the electric power source and ground have been firmly connected.
4. Be sure all pressure connections are tight.
5. Check to be certain all safety relief valves, etc., are correctly installed.
6. Check that all fuses, circuit breakers, etc., are the proper size.
7. Make sure the inlet filter is properly installed.
8. Confirm that the drain valve is closed.
9. Visually check the rotation of the compressor pump. If the rotation is incorrect, have a qualified electrician correct the motor wiring.

START-UP AND OPERATION

1. Follow all the procedures under "Before start-up" before attempting operation of the compressor.
2. Switch the electric source breaker on.
3. Open the tank discharge valve completely.
4. Check that the compressor operates without excessive vibration, unusual noises or leaks.
5. Close the discharge valve completely.
6. If the pressure does not rise on a three phase unit, turn the unit off. Have a qualified electrician switch the breaker OFF and exchange the R and T connections (two out of three phases of electric source) inside the magnetic switch.
7. Check the discharge pressure. Also make sure the air pressure rises to the designated pressure setting by checking the discharge pressure gauge.
8. Check the operation of the pressure switch by opening the stop valve and confirming the compressor starts as pressure drops.

Scroll Air Compressors Tankmount/Basemount

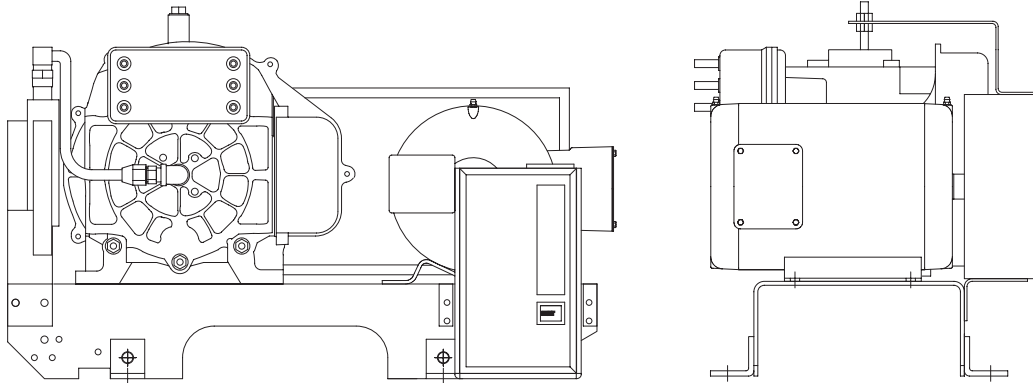

Figure 1 - SBSH Scroll Basemount Simplex

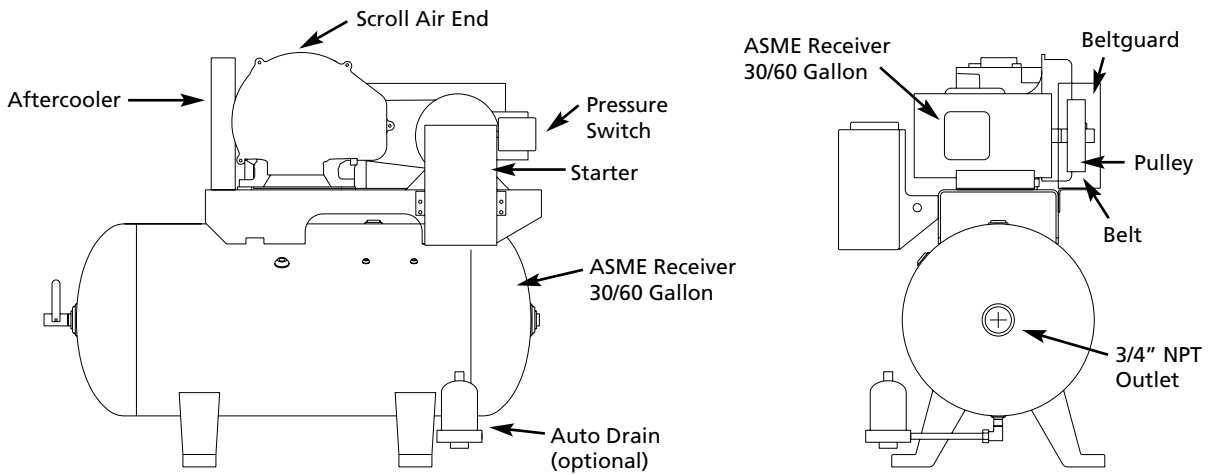

Figure 2 - STSH Scroll Tankmount

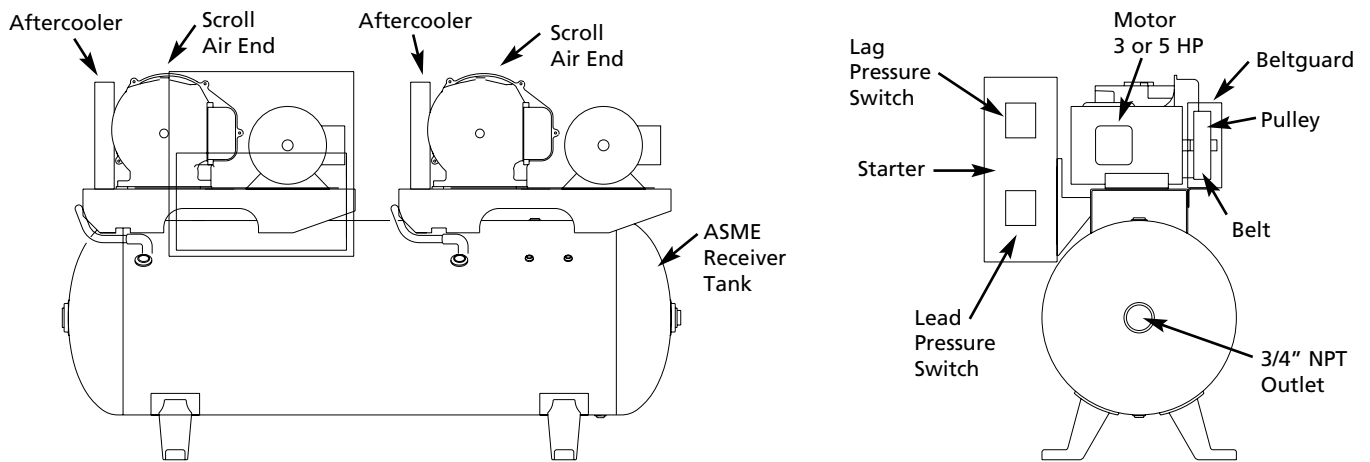

Figure 3 - STDH Scroll Tankmount Duplex

Scroll Air Compressors Tankmount/Basemount

Specifications

Scroll Basemount Simplex - Model SBSH

Model	HP	Phase	SCFM @145 PSIG	Voltage	Full Load Amperage	Gallon Tank	Dimension LxWxH	Ship Weight (Lbs.)
SBSH0307	3	3	7.5	208/230/460	8.7/8.0/4.0	Basemount	29x19x19	160
SBSH1307	3	1	7.5	230	17	Basemount	29x19x19	175
SBSH0507	5	3	12.0	208/230/460	13.7/13.2/6.6	Basemount	29x19x19	180
SBSH1517	5	1	12.0	230	25	Basemount	29x19x19	190

Scroll Tankmount Simplex - Model STSH

Model	HP	Phase	SCFM @145 PSIG	Voltage	Full Load Amperage	Gallon Tank	Dimension LxWxH	Ship Weight (Lbs.)
STSH030	3	3	7.5	208/230/460	8.7/8.0/4.0	30 / 60	39x22x35 / 51x23x39	280 / 390
STSH130	3	1	7.5	230	17	30 / 60	39x22x35 / 51x23x39	295 / 405
STSH050	5	3	12.0	208/230/460	13.7/13.2/6.6	30 / 60	39x22x35 / 51x23x39	300 / 410
STSH151	5	1	12.0	230	25	30 / 60	39x22x35 / 51x23x39	310 / 420

Scroll Tankmount Duplex - Model STDH

Model	HP	Phase	SCFM @145 PSIG	Voltage	Full Load Amperage	Gallon Tank	Dimension LxWxH	Ship Weight (Lbs.)
STDH030	3 (2)	3	15.0	208/230/460	17.4/16.0/8.0	80	64x26x40	650
STDH130	3 (2)	1	15.0	230	34	80	64x26x40	680
STDH050	5 (2)	3	24.0	208/230/460	27.4/26.4/13.2	80 / 120	64x26x40 / 71x35x75	690 / 715
STDH151	5 (2)	1	24.0	230	50	80 / 120	64x26x40 / 71x35x75	710 / 735

MODEL SBSH

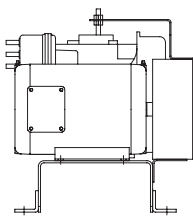

MODEL STSH

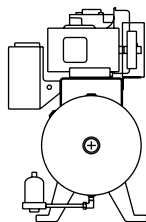

MODEL STDH

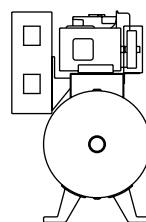

OPTIONAL EQUIPMENT

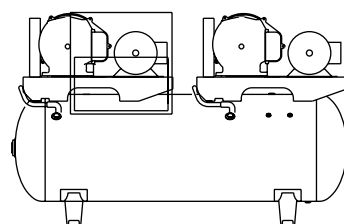
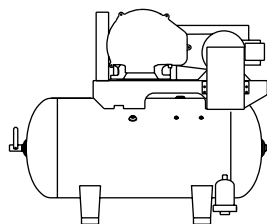
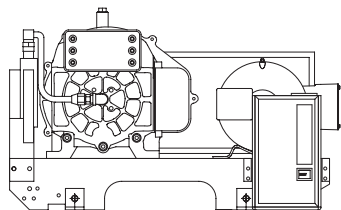
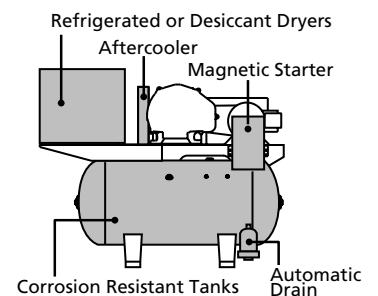

Scroll Air Compressors Tankmount/Basemount

Maintenance Schedule

Item	Action needed	500	2500	Operating Hours			20,000	Remarks
				5000	10,000	15,000		
Pump	Replace						▲	
Tank	Drain moisture	Daily						
Inlet air filter	Replace	●	▲	<i>(Every 2,500 hrs or less)</i>				Part #IP032901AV
Blower fan	Clean			●	●	●		
Fan Duct	Clean			●	●	●		
Compressor Fins	Clean		●	<i>(Every 2,500 hrs or less)</i>				
Bearings	Grease			▲	▲	▲		Service Center Only
Tip seal	Replace			▲	▲	▲		
Dust seal	Replace			▲	▲	▲		
V-belt	Inspect, replace	*Note 3	●	▲	▲	▲	▲	
Pressure Switch	Confirm operation				●		●	
Magnetic starter	Inspect				●		●	Replace if contact points deteriorated
Safety valve	Confirm operation		●	<i>(Every 2,500 hrs or less)</i>				
Pressure gauge	Inspect		●	<i>(Every 2,500 hrs or less)</i>				
●	Inspect							
▲	Replace							

NOTES:

1. Inspect and perform maintenance periodically according to maintenance schedule.
2. The maintenance schedule relates to the normal operating conditions. If the circumstances and load condition are adverse, shorten the cycle time and do maintenance accordingly.
3. * The tension of the V-belt should be adjusted during the initial stage and inspected every 2,500 hours afterwards. Proper belt tension for 3 HP units is 7 lbs./1.16" deflection; for 5 HP units, 7 lbs./1.19" deflection.
4. See Compressor Pump Manuals for replacement or service procedures.

Scroll Air Compressors Tankmount/Basemount

Electrical Wiring Diagram - Simplex

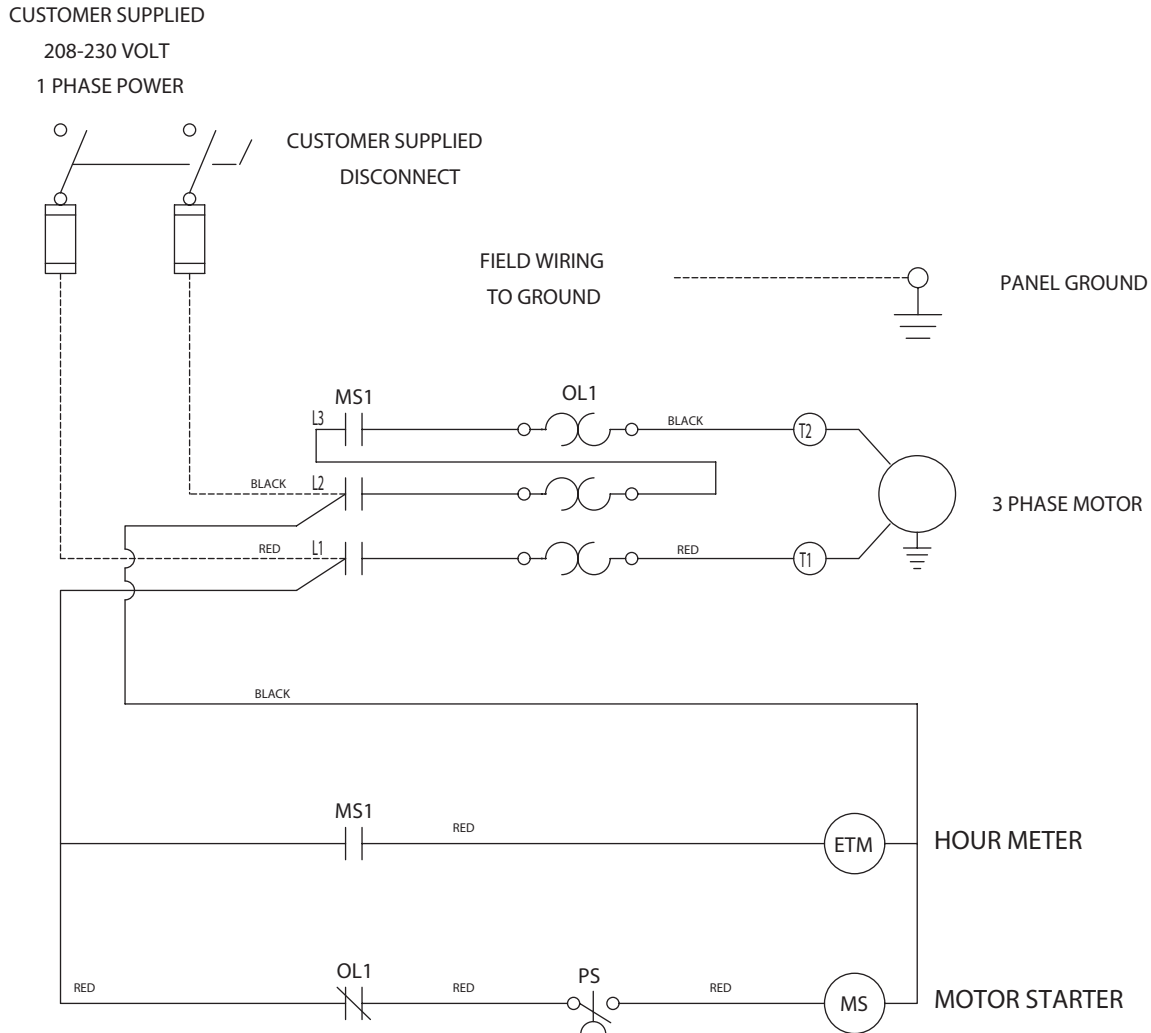

*Main disconnect and branch circuit protection to be installed by a qualified electrician in accordance with national and local codes.

Figure 4 - 3-5 HP Basemount/Simplex Single-Phase 208/230 Volts

Scroll Air Compressors Tankmount/Basemount

Electrical Wiring Diagram - Simplex

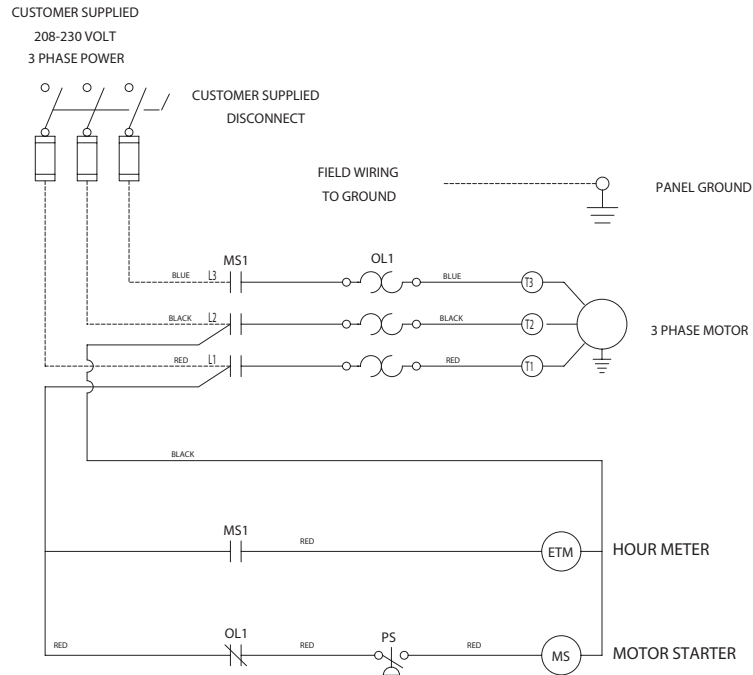

Figure 5 - 3-5 HP Basemount/Simplex Three-Phase 208-230 Volts

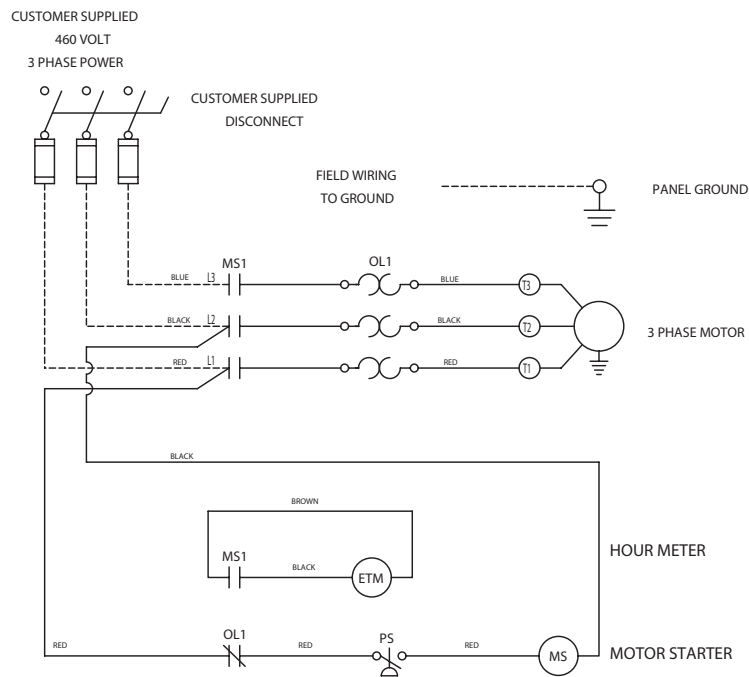

Figure 6 - 3-5 HP Basemount/Simplex Three-Phase 460 Volts

*Main disconnect and branch circuit protection to be installed by a qualified electrician in accordance with national and local codes.

Scroll Air Compressors Tankmount/Basemount

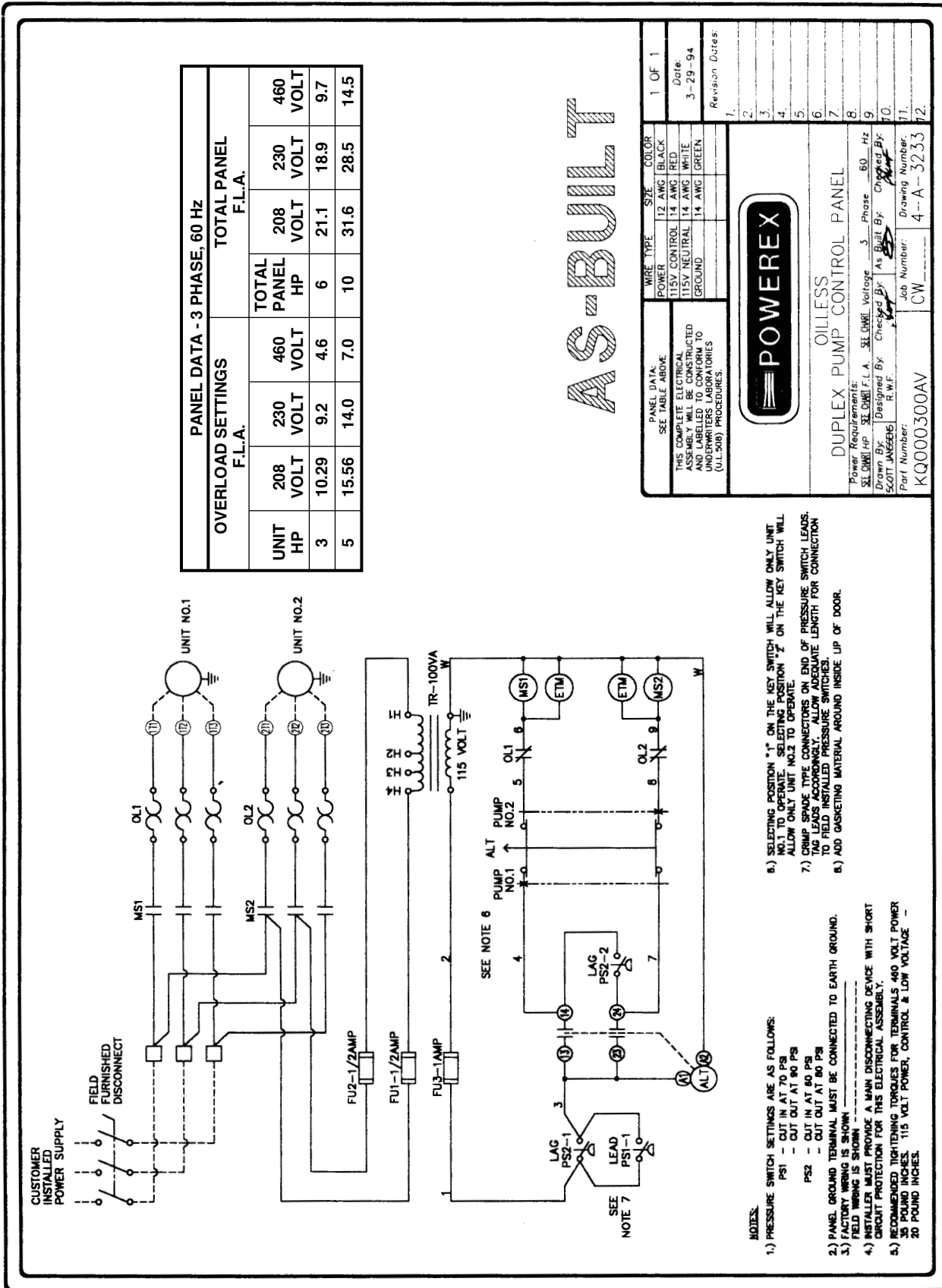
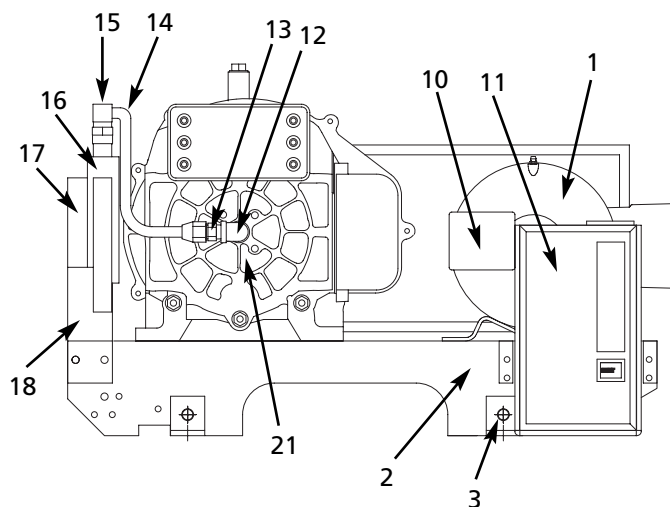
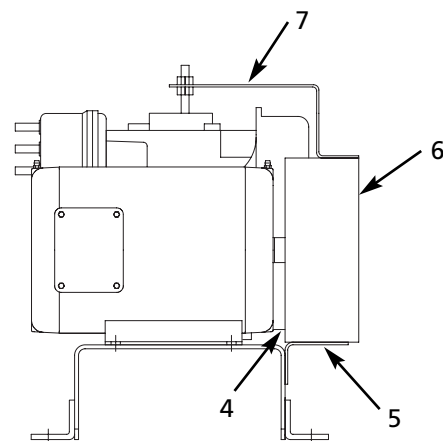

Figure 7 - 3-5 HP Duplex Three-Phase 208-230/460 Volts

Replacement Parts List for SBSH Models

Ref. No.	Description	SBSH Model Part Number	Qty.
1	Motor 3 HP 3 Phase	MC022374AV	1
	Motor 3 HP 1 Phase	MC301519AV	1
	Motor 5HP 3 Phase	MC022307AV	1
	Motor 5HP 1 Phase	MC301520AV	1
2	Base	BA000301AV	1
3	Angle bracket	ST185500AV	4
4	Beltguard back	BG303800AV	1
5	Bracket	SL050700AV	1
6	Beltguard front	BG303900AV	1
7	3 HP Beltguard bracket	BG304000AV	1
	5 HP Beltguard bracket	BG304100AV	1
8 Δ	Belt:		
	3 HP	BT012000AV	1
	5 HP	BT012000AV	2
9 Δ	Motor pulley:		
	3 HP	PU009793AV	1
	5 HP	PU009794AV	1
10	Pressure switch	CW207595AV	1
11	Starter:		
	3 HP 230V 1 Phase	JP001045AV	1
	5 HP 230V 1 Phase	IP001046AV	1
	3 HP 230V 3 Phase	JP001047AV	1
	5 HP 230V 3 Phase	JP001049AV	1
	3 HP 460V 3 Phase	JP001048AV	1
	5 HP 460V 3 Phase	JP001050AV	1
12	90° Elbow	ST074204AV	1
13	1/2" Flare	ST126207AV	1
14	Discharge tube	SL300900AV	1
15	90° Flare elbow	ST126204AV	1
16	Aftercooler	SL300100AV	1
17	Aftercooler mounting bracket	AG007501AJ	4
18	Left/Right aftercooler bracket	SL300400AV	2
19 Δ	Check valve	IP087700AV	1
20 Δ	Safety valve	V-215401AV	1
21	Scroll air end:		
	3 HP	SL014010AJ	1
	5 HP	SL016510AJ	1

(Δ) Not shown.



Replacement Parts List for STSH Models

Ref. No.	Description	STSH Model Part Number	Quantity
1	Motor:		
	3 HP 3 Phase	MC022374AV	1
	3 HP 1 Phase	MC301519AV	1
	5 HP 3 Phase	MC022307AV	1
	5 HP 1 Phase	MC301520AV	1
2	Starter:		
	3 HP 230V 1 Phase	JP001045AV	1
	5 HP 230V 1 Phase	JP001046AV	1
	3 HP 230V 3 Phase	JP001047AV	1
	5 HP 230V 3 Phase	JP001049AV	1
	3 HP 460V 3 Phase	JP001048AV	1
	5 HP 460V 3 Phase	JP001050AV	1
3	Receiver tank:		
	30 gallon	AR024700AJ	1
	60 gallon	AR022500AJ	1
4	Beltguard	BG303900AV	1
5	Motor pulley:		
	3 HP	PU009793AV	1
	5 HP	PU009794AV	1
6	Guard plate	BG217500AV	1
7	Aftercooler	SL300100AV	1
8	Tube air end/aftercooler	SL301000AP	1
9	Tube aftercooler/tank	SL300900AP	1
10	Check valve	IP087700AV	1
11	Pressure gauge	GA016701AV	1
12	Safety valve	V-215401AV	1
	Pressure switch	CW207595AV	1
14	Scroll air end:		
	3 HP	SL014010AJ	1
	5 HP	SL016510AJ	1
15	Belt:		
	3 HP	BT012000AV	1
	5 HP	BT012000AV	2

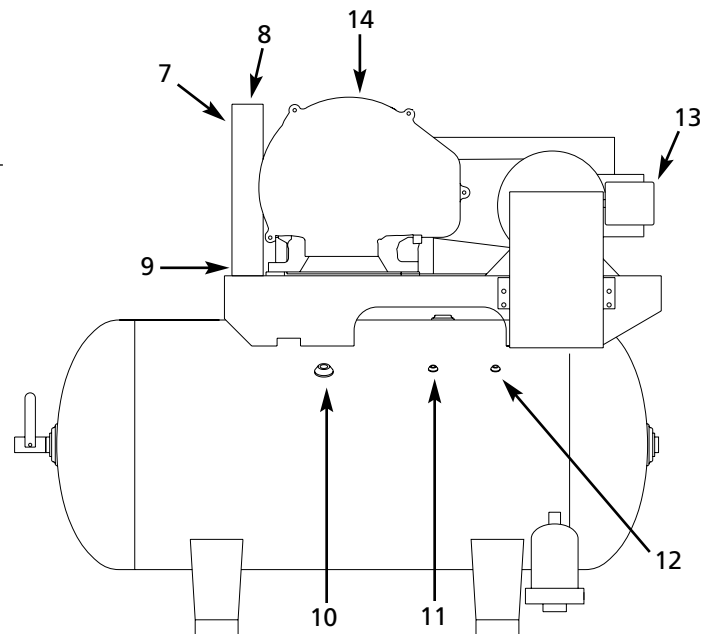
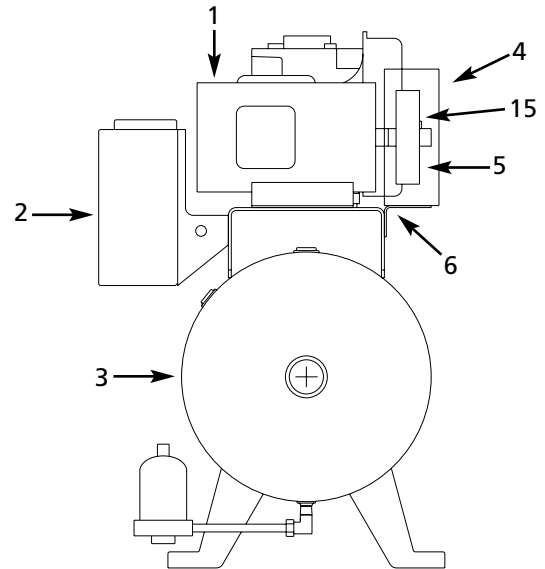

Replacement Parts List for STDH Models

Ref. No.	Description	STDH Model Part Number	Quantity
1	Motor:		
	3 HP 3 Phase	MC022374AV	2
	3 HP 1 Phase	MC301519AV	2
	5 HP 3 Phase	MC022307AV	2
	5 HP 1 Phase	MC301520AV	2
2	Starter alternator panel:		
	3 HP 230V 1 Phase	ZZ000435AJ	1
	5 HP 230V 1 Phase	ZZ000436AJ	1
	3 HP 230V 3 Phase	ZZ000418AJ	1
	5 HP 230V 3 Phase	ZZ000419AJ	1
	3 HP 460V 3 Phase	ZZ000420AJ	1
	5 HP 460V 3 Phase	ZZ000421AJ	1
3	Receiver tank:		
	80 gallon	AR022900AJ	1
	120 gallon	AR023600AJ	1
4	Beltguard	BG303900AV	1
5	Belt:		
	3 HP	BT012000AV	2
	5 HP	BT012000AV	4
6	Motor pulley:		
	3 HP	PU009793AV	2
	5 HP	PU009794AV	2
7	Guard plate	BG217500AV	2
8	Aftercooler	SL300100AV	2
9	Tube air end/aftercooler	SL301000AP	2
10	Tube aftercooler/tank	SL300900AP	2
11	Check valve	IP087700AV	2
12	Pressure gauge	GA016701AV	1
13	Safety valve	V-215401AV	1
14	Pressure switch (Lead)	CW207574AV	1
15	Pressure switch (Lag)	CW207595AV	1
16	Scroll air end:		
	3 HP	SL014010AJ	2
	5 HP	SL016510AJ	2

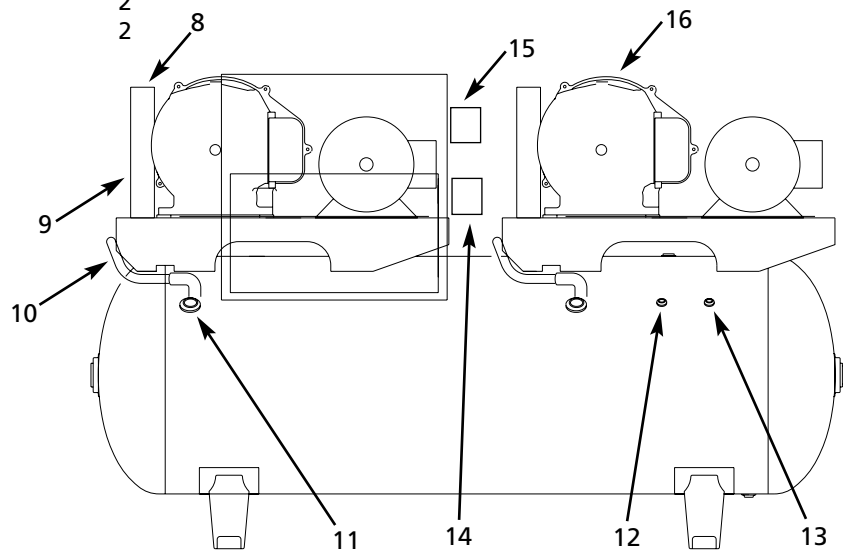
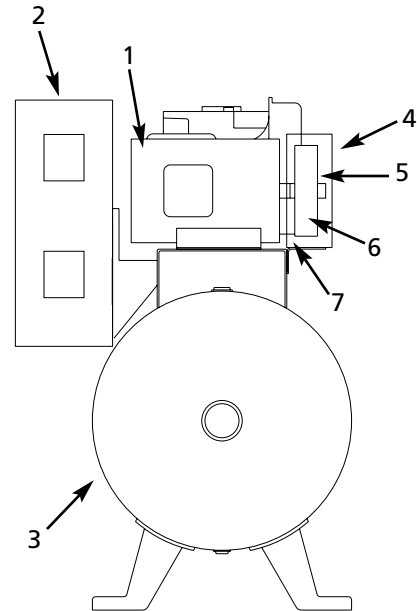

Scroll Air Compressors Tankmount/Basemount

Powerex Limited Warranty

POWEREX 3 YEAR / 10,000 HOUR EXTENDED PARTS LIMITED WARRANTY - Powerex warrants each Compressor Pump or Scroll Air-End against defects in material or workmanship from the date of purchase for a period of **Three years or 10,000 hours**, whichever may occur first. This warranty applies to the exchange of part(s) of the compressor pump or air-end found to be defective by an Authorized Powerex Service Center.

POWEREX 1 YEAR / 5,000 HOUR INLET TO OUTLET LIMITED WARRANTY - Powerex warrants each Compressor Unit, System, Pump, or Air-End against defects in material or workmanship from the date of purchase for a period of **One Year or 5,000 Hours**, whichever may occur first. This warranty applies to the exchange of defective component part(s) and labor performed by an Authorized Powerex Service Center.

Coverage. The above mentioned warranty applies to Powerex manufactured units or systems only. Items listed in the operator's manual under routine maintenance are not covered by this or any other warranty. Failure to complete maintenance as stated in the maintenance schedule will void this warranty.

THERE IS NO OTHER EXPRESS WARRANTY. IMPLIED WARRANTIES, INCLUDING THOSE OF MERCHANTABILITY AND FITNESS FOR A PARTICULAR PURPOSE, ARE LIMITED TO ONE YEAR FROM THE DATE OF PURCHASE: AND TO THE EXTENT PERMITTED BY LAW, ANY AND ALL IMPLIED WARRANTIES ARE EXCLUDED. THIS IS THE EXCLUSIVE REMEDY AND LIABILITY FOR CONSEQUENTIAL DAMAGES UNDER ANY AND ALL WARRANTIES IS EXCLUDED TO THE EXTENT EXCLUSION IS PERMITTED BY LAW.

Limitation of Liability. To the extent allowable under applicable law, Powerex's liability for consequential and incidental damages is expressly disclaimed. Powerex's liability in all events is limited to, and shall not exceed, the purchase price paid.

Warranty Disclaimer. Powerex has made a diligent effort to illustrate and describe the products in this literature accurately; however, such illustrations and descriptions are for the sole purpose of identification, and do not express or imply a warranty that the products are merchantable, or fit for a particular purpose, or that the products will necessarily conform to the illustrations or descriptions.

Product Suitability. Many jurisdictions have codes and regulations governing sales, construction, installation, and/or use of products for certain purposes, which may vary from those in neighboring areas. While Powerex attempts to assure that its products comply with such codes, it cannot guarantee compliance, and cannot be responsible for how the product is installed or used. Before purchase and use of a product, please review the product applications, and national and local codes and regulations, and be sure that the product, installation, and use will comply with them.

Claims. Claims pertaining to the merchandise in this schedule, with the exception of warranty claims, must be filed with POWEREX within 6 months of the invoice date, or they will not be honored. Prices, discounts and terms are subject to change without notice or as stipulated in specific product quotations. All agreements are contingent upon strikes, accidents, or other causes beyond our control. All shipments are carefully inspected and counted before leaving the factory. Please inspect carefully any receipt of merchandise noting any discrepancy or damage on the carrier's freight bill at the time of delivery. Discrepancies or damage which obviously occurred in transit are the carrier's responsibility and related claims should be made promptly directly to the carrier. Returned merchandise will not be accepted without prior written authorization by POWEREX and deductions from invoices for shortage or damage claims will not be allowed.

UNLESS OTHERWISE AGREED TO IN WRITING, THESE TERMS AND CONDITIONS WILL CONTROL IN ANY TRANSACTION WITH POWEREX any different or conflicting terms as may appear on any order form now or later submitted by the buyer. All orders are subject to acceptance by POWEREX.