

Scroll Enclosure Air Compressors

Please read and save these instructions. Read carefully before attempting to assemble, install, operate or maintain the product described. Protect yourself and others by observing all safety information. Failure to comply with instructions could result in personal injury and/or property damage! Retain instructions for future reference.

Description

GENERAL

The Powerex Oilless Rotary Scroll Air Compressor has advanced scroll compressor technology through the development of a completely oilless unit. The Powerex Scroll Compressor offers a dynamically balanced air end which insures vibration-free operation. The rotary design permits a continuous 100% duty cycle. No oil separation, oil filtration, or inlet valves are required on the Powerex Scroll unit. The compressor is virtually maintenance free.

Other standard features on the Powerex Scroll Compressor include: a Magnetic Starter, Motor Overload Protection, a High Temperature Shutdown Switch, an Air Cooled Aftercooler and a Single Phase or Three Phase 4 Pole ODP motor.

Safety Guidelines

This manual contains information that is very important to know and understand. This information is provided for SAFETY and to PREVENT EQUIPMENT PROBLEMS. To help recognize this information, observe the following symbols.

⚠ DANGER *Danger indicates an imminently hazardous situation which, if not avoided, WILL result in death or serious injury.*

⚠ WARNING *Warning indicates a potentially hazardous situation which, if not avoided, COULD result in death or serious injury.*

⚠ CAUTION *Caution indicates a potentially hazardous situation which, if not avoided, MAY result in minor or moderate injury.*

NOTICE *Notice indicates important information, that if not followed, MAY cause damage to equipment.*

Unpacking

After unpacking the unit, inspect carefully for any damage that may have occurred during transit. Make sure to tighten fittings, bolts, etc., before putting unit into service.

⚠ WARNING *Do not operate unit if damaged during shipping, handling or use. Damage may result in bursting and cause injury or property damage.*

1. The compressor nameplate should be checked to see if the unit is the correct model and voltage as ordered.

⚠ CAUTION *Remove the yellow bracket located between the base and receiver inside the front panel.*

General Safety Information

The **operator** of this compressor **must** take the necessary precautions to prevent the level of danger indicated by these symbols. The operator is also required to read and understand this instruction manual and all safety warnings, labels, etc.

Any **employer** allowing the use of this compressor in their field of work **must** distribute this instruction manual to all users. The employer must also ensure all users read, understand and follow the instructions as described in the manual, safety warnings, labels, etc.

1. Read and understand all safety warnings and instructions before operating this compressor. Failure to read and follow all safety warnings may result in serious personal injury or death. Property damage and/or compressor damage may also occur if all warnings are not followed.

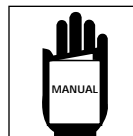

⚠ DANGER

Breathable Air Warning

This compressor/pump is NOT equipped and should NOT be used "as is" to supply breathing quality air. For any application of air for human consumption, you must fit the air compressor/pump with suitable in-line safety and alarm equipment. This additional equipment is necessary to properly filter and purify the air to meet minimal specifications for Grade D breathing as described in Compressed Gas Association Commodity Specification G 7.1 - 1966, OSHA 29 CFR 1910.134, and/or Canadian Standards Associations (CSA).

DISCLAIMER OF WARRANTIES IN THE EVENT THE COMPRESSOR IS USED FOR THE PURPOSE OF BREATHING AIR APPLICATION AND PROPER IN-LINE SAFETY AND ALARM EQUIPMENT IS NOT SIMULTANEOUSLY USED, EXISTING WARRANTIES ARE VOIDED, AND POWEREX DISCLAIMS ANY LIABILITY WHATSOEVER FOR ANY LOSS, PERSONAL INJURY OR DAMAGE.

2. Air used for breathing or food processing must meet O.S.H.A. 29 C.F.R. 1910.134 or C.F.R. 178.3570 regulations.
3. Do not expose the compressor intake to flammable gases, vapors or fumes.
4. Do not use or store flammable gases in or near the compressor.
5. Safety Valves or Relief Valves used on this compressor must be in accor-





Scroll Enclosure Air Compressors

General Safety Information (Cont.)

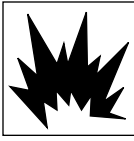
dance with ANSI/ASME B19 safety standards. Improperly sized Safety Valves will result in serious personal injury or death.

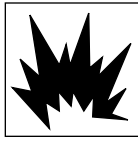
6. Do not remove the panel or try to service the air compressor while the compressor is running or while the air receiver is under pressure. Serious personal injury or death will occur. 
7. Never use rubber hoses, plastic piping or soldered joints in any part of the compressed air or gas system. The compressor and system piping must be compatible.
8. The compressor will shutoff when the pressure reaches a predetermined maximum pressure. Care should be used since the compressor may suddenly restart automatically when the pressure drops to the predetermined minimum pressure. Never assume the compressor is ready for service just because the unit is stopped.
9. All pressure must be drained from the compressor and the electrical source must be turned off before attempting to inspect or repair the unit.
10. Keep clear of all moving parts especially if the compressor is operating with the door panel removed for inspection or repair.
11. Do not touch HOT parts of the compressor such as the air end, discharge pipe, aftercooler, motor etc. 
12. Keep flammable gases away from the compressor. Parts of the compressor become very hot during operation and the vapors from flammable gases may cause the unit to explode.
13. Never use flammable or toxic solvents to clean the compressor or any of the unit's parts.
14. Do not remove or tamper with any safety devices, guards, panels or insulation parts while compressor is in operation. All guards or panels must be in place before starting or operating the compressor.

15. Install a properly sized Safety Relief Valve in the discharge piping ahead of or before a shut-off valve, heat exchanger, orifice, etc. The compressor or part of the system could rupture or explode if a Safety Relief Valve is not installed. 
16. Do not change the pressure setting of the Safety Relief Valve. Do not replace the Safety Relief Valve with a plug or restrict the Safety Relief Valve. The system or the compressor may be over-pressurized if the Safety Relief Valve is tampered with in any way.
17. Do not service the compressor or any compressor part while the unit is in operation.
18. Do not remove, disconnect or tamper with the High Temperature Shutdown Switch. The High Temperature Shutdown Switch must be installed on the compressor to protect against high temperatures damaging the compressor.
19. All electrical connections should be made by a qualified electrician.
20. Disconnect all power supplies to the compressor before opening the electrical box or before servicing the unit. High voltage may be present. 
21. Never remove or alter any safety warning labels, tags, etc. located on or provided with compressor.
22. Always provide a clean air source for your compressor. Keep all piping direct and short when using an outside air source.
23. Locate compressor inlet system away from possible ingestion of flammable or toxic vapors, water, dirty air or air temperatures exceeding 110° F.
24. Never set the pressure switch to a higher setting than the one provided from the factory.
25. Check all gauges daily to be sure the compressor is operating correctly.
26. Follow all directions for maintenance. Check all safety devices according to instructions.
27. Never attempt to lift or move the compressor except when using the

- proper lifting procedures.
28. Make sure all electrical components follow the National Electric code and all state and local codes when installing the compressor.
29. Do not operate the compressor if unusual noise or vibration occurs.
30. Keep all panels in place at all times.
31. Standard motors are not appropriate for dirty, wet or explosive areas.
32. All service should be performed by trained and qualified people only.
33. The Drive Belt tension should be checked often during initial operation of the compressor.
34. Never substitute oil bath or oil wetted filters for the inlet filters provided with the compressor.

Component Description

COMPRESSION CYCLE

The Powerex Oilless Rotary Scroll Air Compressor is based on the theory of scroll compression. A scroll is a free standing, intricate spiral bounded on one side by a solid, flat plane or base. A scroll set, the basic compression element of a scroll compressor, is made up of two identical spirals which form right and left hand parts. One of these scroll components is indexed or phased 180° with respect to the other so the scrolls can mesh. Crescent-shaped gas pockets are formed and bounded by the spirals and the base plate of both scrolls. As the moving scroll is orbited around the fixed scroll, the pockets formed by the meshed scrolls follow the spiral toward the center and diminish in size. The moving scroll is prevented from rotating during this process so the 180° phase relationship of the scrolls is maintained. The compressor's inlet is at the outer boundary of the scrolls. The entering gas is trapped in two completely opposite gas pockets and compressed as the pockets move toward the center. The compressed gas is discharged through the outlet at the center of the fixed scroll so no valves are needed.

MAGNETIC STARTER

The magnetic starter on the scroll compressor is installed in a NEMA 1 enclosure located inside the front panel of the unit.

Component Description (Cont.)

MOTOR OVERLOAD PROTECTION

The motor overload protection on the scroll compressor is controlled by an overload relay which is located beneath the magnetic starter. Please refer to the electrical drawings for specifications.

CONTROL TRANSFORMER

The control transformer on the scroll compressor is located inside the magnetic starter panel. Line voltage is reduced to 120 volts for operation of the hourmeter, ventilation fan, circuit board and pressure switch.

SINGLE OR THREE PHASE MOTOR

Powerex single phase motors are standard, open, drip-proof, NEMA frame motors suitable for 230V operation. Powerex three phase motors are standard, open, drip-proof, NEMA frame motors suitable for 208V, 230V and 460V operation.

TIP SEAL

The tip seal on the scroll compressor is self-lubricated and allows the unit to operate efficiently without oil and expensive filtration. The tip seal should be replaced every 10,000 hours of operation.

BEARINGS

The bearings on the scroll compressor are regreaseable to allow extended compressor life. Service should be performed every 5,000 hours of operation.

AIR COOLED AFTERCOOLER

The air cooled aftercooler on the scroll compressor is a series of deep alloy cooling fins and a high output cooling fan. These cooling features allow the scroll compressor to operate at lower temperatures and extend bearing, tip seal and grease life. The aftercooler works to cool the compressor by reducing the amount of water condensation in the discharge air. The temperature of the discharge air is lowered by allowing the contained water to be trapped and discharge through the drain valve.

DRY TYPE INLET FILTER - (PART # IP032901AV)

The inlet filter on the scroll compressor assures 99% of particulate free air is admitted to the unit. Please order part # IP032901AV for both the 3 HP and 5

HP units. Change every 2,500 hours or more often in dirty locations.

COOLING AIR CLEANABLE FILTER SCREEN

The cooling air cleanable filter screen on the scroll compressor is located on the back panel of the unit and should be cleaned periodically.

HOURLMETER

The hourmeter on the scroll compressor indicates the actual number of hours the unit has been in operation. The hourmeter is also used to determine maintenance and service timing. **An hourmeter must be installed with every Scroll compressor.**

HIGH TEMPERATURE SHUTDOWN SWITCH

The high temperature shutdown switch on the scroll compressor protects the unit when an unusually high temperature in the air end is detected. The compressor will shutdown when this high temperature is detected.

PRESSURE SWITCH

The pressure switch on the scroll compressor is a transducer type and is located in the rear of the unit on the air receiver.

AIR PRESSURE GAUGE

The air pressure gauge on the scroll compressor is used to indicate the amount of pressure available for use.

CONDENSATE DRAIN VALVE - MANUAL

The condensate drain valve on the scroll compressor allows the discharge of water trapped in the unit by the aftercooler.

NOTICE *Drain liquid from tank daily.*

SERVICE VALVE

The service valve on the scroll compressor is located on the lower right side of the unit. The discharge valve is 3/8" NPT.

Installation

INSTALLATION SITE

1. The scroll compressor must be located in a clean, well lit and well ventilated area.
2. The area should be free of excessive dust, toxic or flammable gases and moisture.

3. Never install the compressor where the ambient temperature is higher than 104° F or where humidity is high.
4. Clearance must allow for safe, effective inspection and maintenance. 20" of clearance for sides, 12" clearance for back is recommended.
5. If necessary, use metal shims or leveling pads to level the compressor. Never use wood to shim the compressor.

VENTILATION

1. If the scroll compressor is located in a totally enclosed room, an exhaust fan with access to outside air must be installed.
2. Never restrict the cooling fan exhaust air.
3. Vent the exhaust air outside to prevent the compressor from operating at high temperatures and shutting down.
4. Never locate the compressor where hot exhaust air from other heat generating units may be pulled into the unit.

WIRING

All electrical hook-ups must be performed by a qualified electrician. Installations must be in accordance with local and national electrical codes.

1. Use solderless terminals to connect the electric power source.
2. Remove the front panel.
3. Open the lid of the starter box, installed below the inlet filter, by loosening the lower screws with a screw driver.
4. Pull the electric cable through the electric source inlet and connect to the primary side of the magnet.

PIPING

1. Make sure the piping is lined up without being strained or twisted when assembling the piping for the scroll compressor.
2. Appropriate expansion loops or bends should be installed at the compressor to avoid stresses caused by changes in hot and cold conditions.

Scroll Enclosure Air Compressors

3. Piping supports should be anchored separately from the compressor to reduce noise and vibration.
4. Never use any piping smaller than the compressor connection.
5. Use flexible hose to connect the outlet of the compressor to the piping so that the vibration of the compressor does not transfer to the piping.

SAFETY VALVES

Tank mounted compressors are shipped from the factory with safety valves installed in the air receiver manifold. The flow capacity of the safety valve is equal to or greater than the capacity of the compressor.

1. The pressure setting of the safety valve must be at least 10 psi less than the maximum working pressure of the air receiver.
2. Safety valves should be placed ahead of any possible blockage point in the system, i.e. shutoff valve.
3. Avoid connecting the safety valve with any tubing or piping.
4. Manually operate the safety valve every six months to avoid sticking or freezing.

Operation

BEFORE START UP

1. Make sure all safety warnings, labels and instructions have been read and understood before continuing.
2. Remove any shipping materials, brackets, etc.
3. Confirm that the electric power source and ground have been firmly connected.
4. Check the belts for tightness.
5. Be sure all pressure connections are tight.
6. Check to be certain all safety relief valves, etc., are correctly installed.
7. Securely mount all panels and guards.
8. Check that all fuses, circuit breakers, etc., are the proper size.
9. Make sure the inlet filter is properly installed.

10. Confirm that the drain valve is closed.
11. Visually check the rotation of the compressor pump. The rotation should be counterclockwise if viewing the compressor from the belt-guard side. If the rotation is incorrect, have a qualified electrician correct the motor wiring.
12. Remove the yellow bracket attached to the front bottom which is for transportation purposes only.

START-UP AND OPERATION

1. Follow all the procedures under "Before start-up" before attempting operation of the compressor.
2. Switch the electric source breaker ON.
3. Make sure electric source lamp lights up and that the alarm lamp does not light up.

Note: The alarm lamp light will come on if temperature sensor is not connected. If the sensor is not connected, have a qualified service person reconnect the sensor.

4. Open the discharge valve completely.
5. Push ON button and check that the compressor operates without excessive vibration, unusual noises or leaks.
6. Close the discharge valve completely.
7. **If the pressure does not rise on a three phase unit, turn the unit off. Have a qualified electrician switch the breaker OFF and exchange the L₁ and L₂ connections (two out of three phases of electric source) inside the magnetic switch.**
8. Check the discharge pressure. Also make sure the air pressure rises to the designated pressure setting by checking the discharge pressure gauge.
9. Check the operation of the pressure switch by opening the stop valve and confirming the compressor starts at 93 psig.

DAILY OPERATION

1. Stop the compressor by pushing the OFF button.

NOTE: If the compressor rotates in reverse for more than five seconds, the check valve needs to be cleaned or replaced.

2. Switch the breaker OFF if the compressor is not to be used for a long period of time.

STOPPING THE COMPRESSOR DURING NORMAL OPERATION

1. Close the discharge valve.
2. Allow the air pressure to build and the compressor to stop.
3. Turn the compressor off by pushing the OFF button.

STOPPING THE COMPRESSOR DURING EMERGENCY OPERATION

1. Stop the compressor by pushing the OFF button or by turning the power off at the main disconnect panel.

Specifications

Compressor

Model Number	Air End	Control System	Discharge Pressure (PSIG)	Air Delivery (CFM)	Compressor Speed (RPM)	Driving System	Belt Size	Discharge Air Temp. °F	Discharge Air Outlet	Air Receiver Capacity (Gal.)	Noise Level (1.5m from front)
SLP030	SLAE03	Pressure Switch Control	93-115	8.6	2680	V belt	1-3Vx375	Intake temp. + less than 55	3/8"	10	49
SLP050	SLAE05	Pressure Switch Control	93-115	14.7	3020	V belt	2-3Vx400	Intake temp. + less than 55	3/8"	10	49

Electric Motor

Model Number	Type	Horsepower	Voltage	Starting System
SLP030	3-phase or single phase, drip-proof, 4-pole	3	Single Phase 230V or Three Phase 208/230/460V	Magnetic Starter
SLP050	3-phase or single phase, drip-proof, 4-pole	5	Single Phase 230V or Three Phase 208/230/460V	Magnetic Starter

Safeguard and Others

Model Number	High Temperature Shut-down Switch	Overload Relay	Dimensions (LxWxH)	Approximate Weight
SLP030	Installed	Installed	25 x 24 x 39	242 lbs.
SLP050	Installed	Installed	25 x 24 x 39	341 lbs.

NOTES:

- Noise level is measured in the anechoic room.
- Dimensions are outer dimensions of the package. The extruded parts such as the discharge valve, etc. are not included.
Subject to change without notice.

Chart 1

Scroll Enclosure Air Compressors

Maintenance Schedule

Item	Action needed	Operating Hours				Remarks	
		500	2500	5000	10,000		20,000
Receiver	Drain moisture	Daily					
Cartridge Filter	Clean, replace	●	▲			Part # IP032901AV	
Ventilation Screen	Clean	●					
Blower Fan	Clean			●			
Fan Duct	Clean			●			
Compressor Fins	Clean			●			
Compressor	Grease			▲		Use genuine Powerex grease	
Tip Seal	Replace				▲		
Dust Seal	Replace			●	▲		
V-belt	Inspect, replace	*Readjust ●			▲		
Temperature Sensor	Confirm operation					●	
Pressure Switch	Confirm operation				●		
Magnetic Starter	Inspect				●	Replace if contact points deteriorated	
Safety Valve	Confirm operation				●		
Pressure Gauge	Inspect				●		
Ventilation Fan	Inspect				●	Replace if malfunctions	
Compressor	Overhaul				●	▲	Consult factory

- Inspect
- ▲ Replace

NOTES:

1. Inspect and perform maintenance periodically according to maintenance schedule.
2. The maintenance schedule relates to the normal operating conditions. If the circumstances and load condition are adverse, shorten the cycle time and perform maintenance accordingly.
3. * Marked "Readjust" means the tension of the V-belt should be adjusted during the initial stage and inspected every 2,500 hours afterwards.

Chart 2

Scheduled Maintenance

DRAIN RECEIVER DAILY

1. Open the manual condensate drain located below the discharge air valve.
2. With the receiver pressurized, allow all condensate to drain from the receiver.
3. Close the condensate drain.

INTAKE FILTER

1. Remove the filter panel on the right side of the unit.
2. Remove the air inlet housing, the wing nut and the inlet filter element.
3. Clean the inlet filter element with compressed air or replace with part number IP032901AV.

NOTE: Never clean filter element with solvents or water.

4. Clean the six plastic intake tubes with soap and water.

VENTILATION SCREEN

1. Remove the ventilation screen located at the back of the unit.
2. Clean with compressed air or soap and water, if necessary.

INSPECT V-BELT TENSION

1. Remove the top panel, rear duct and intake panel.
2. Check V-Belt tension with tension gauge.
3. Adjust to the specifications listed in Chart 3.

GREASE COMPRESSOR BEARINGS

1. Remove the plastic dust cap (Key #69) from the airend. See Figure 1.

2. Move the compressor pulley until the grease fitting is visible through the dust cap hole.
3. Use a grease gun extension adapter to engage the grease fitting and supply the proper volume of grease as indicated on the grease delivery chart. See Chart 4.

CAUTION Use only Powerex genuine grease. (Part # IP600000AV). Pump grease gun before feeding to eliminate air from grease passage of the needle adapter.

GREASE PIN CRANK BEARING

1. Remove the back panel.
2. Remove the V-Belt and the fan cover (Key #24).

3. Remove the air end pulley with a gear puller.
4. Remove the fan duct (Key #22).
5. Remove the three grease caps (Key #72). Do not attempt to loosen or tighten the bolt (Key #71)
6. Grease all three pin crank bearings.

CAUTION The grease fitting, located in the center of the pin crank bearing, feeds only the orbit scroll side bearing. Use a needle adapter to supply grease to the housing side bearing. Pump grease gun before feeding to eliminate air from grease passage of the needle adapter. Hold grease gun for 5 - 10 seconds after feeding to prevent grease blowback from the grease fitting.

Model	New Belt Load ± Deflection Kg / 10 mm	Existing Belt Load ± Deflection Kg / 10 mm
SLP03	4 ± 0.5	3.5 ± 0.5
SLP05	6 ± 0.5	5.5 ± 0.5

Chart 3

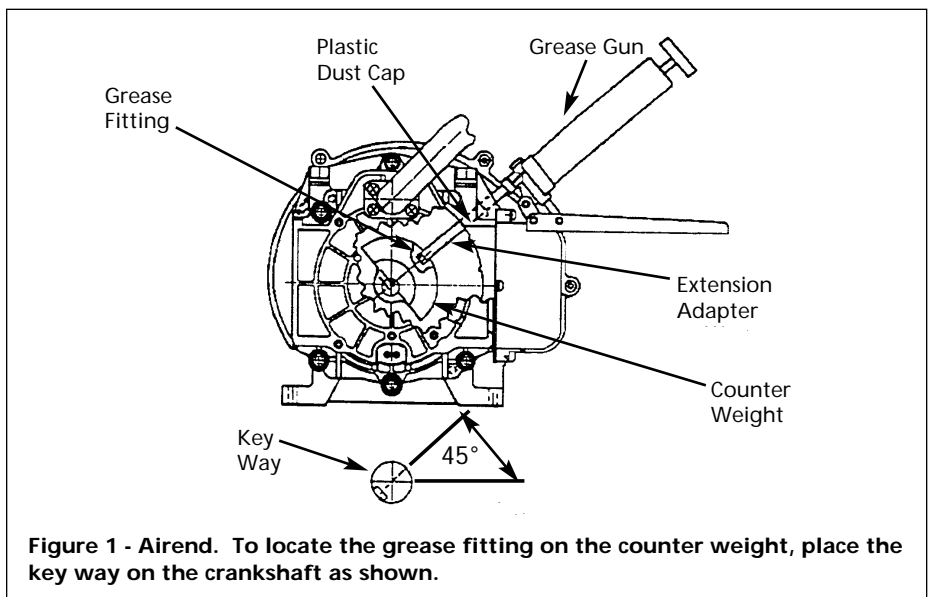

Bearing	SLP03		SLP05	
	1st Time	2nd Time	1st Time	2nd Time
O.S. Bearing	5 times	3 times	6 times	4 times
Pin Crank Bearing O.S. Side	5 times	3 times	6 times	4 times
Pin Crank Bearing Housing Side	5 times	3 times	6 times	4 times

Chart 4 - Grease Delivery

CAUTION Use only Powerex genuine grease, (Part #IP600000AV), or equivalent.

NOTE: Each pump of the grease gun equals 0.65g of grease. The volume of grease is less after the 2nd pump since some of the grease supply will remain in the grease passage.

Scroll Enclosure Air Compressors

Scheduled Maintenance (Cont.)

REPLACE TIP SEAL

1. Remove the front door of the unit.
2. Remove the starter box.
3. Loosen the discharge manifold.
4. Remove the six nuts (Key #60).
5. Remove the stationary scroll housing (Key #1).
6. Take out the old tip seal from the orbiting scroll housing and stationary scroll housing.
7. Remove the old dust seals from both housings.

Install the new tip seals and dust seals in the stationary and orbiting scroll housings in the following manner:

1. Blow off any dust from both scroll housings.
2. Install the high pressure, or shorter tip seal, from the center of the scroll and extend the tip seal outward in the seal channel.

NOTE: The side and bottom lip notches face inward and down into the channel.

3. Install the low pressure, or longer tip seal, in the same way, but make sure there is no gap between the high and low pressure seals.

CAUTION Do not attempt to remove the orbit scroll from the housing.

CAUTION After installing half of the low pressure seal, carefully remove the seal from the channel and make sure the seal is properly locking onto the channel indentations located just past the high pressure seal.

NOTE: The indentations are machined into the seal channel to prevent the low pressure seal from moving.

4. Blow off any dust caused by removing the seal from the seal channel.
5. Install the low pressure seal completely. Make sure the side and bottom lip notches are facing inward and down into the seal channel.

NOTE: The lip notches must not be distorted in the seal or torn off.

6. Install backup tube in the dust seal channel.
7. Place dust seal over the backup tube.

CAUTION The backup tube must meet at the bottom of the housing in the six o'clock position. The dust seal must meet on the right side of the housing, or in the three o'clock position.

8. Install the stationary scroll housing onto the orbiting scroll housing and reassemble the unit.
9. Make sure when reassembling the unit, the Pulley Belt and the Housing Nut follow the specifications as detailed in Chart 5 below.

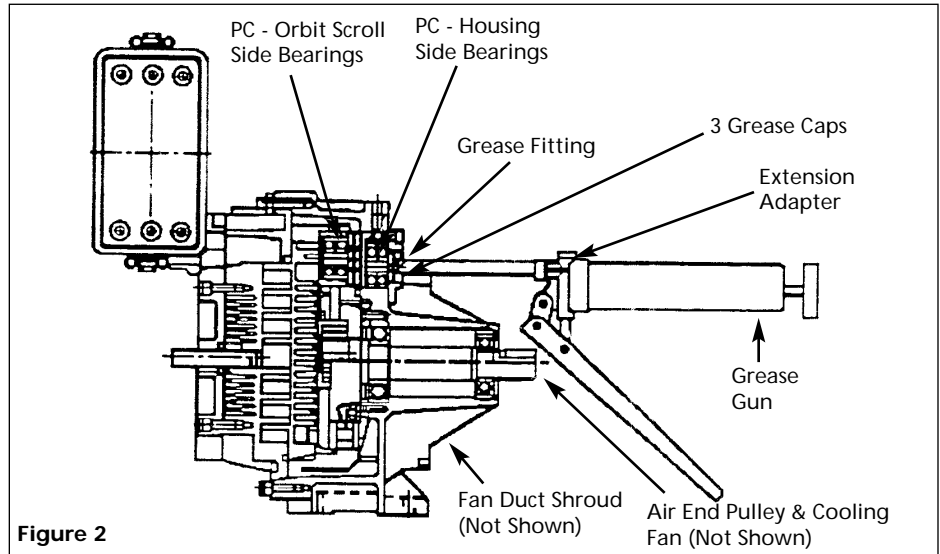

Figure 2

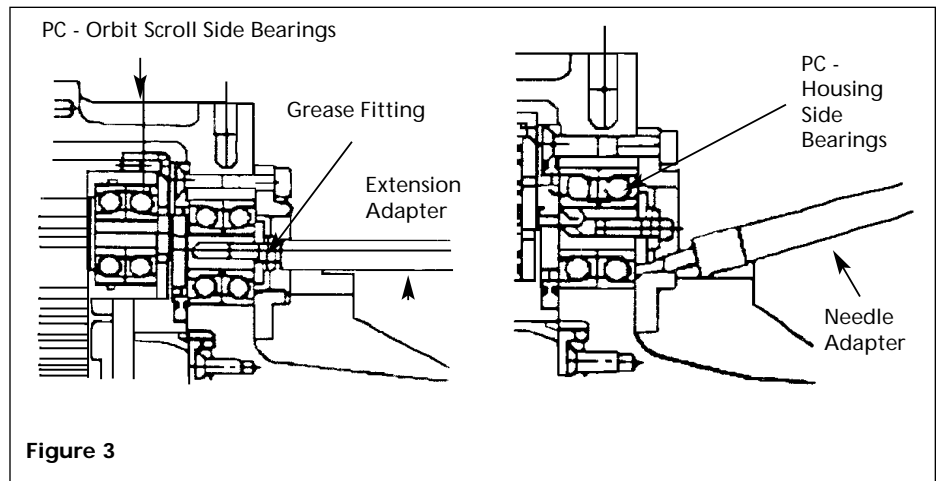

Figure 3

Model	Pulley Belt Key #65		Housing Nut Key #60	
	Size	Torque	Size	Torque
SLP03	M8	175	M8	175
SLP05	M8	175	M10	260

Chart 5 - Belt Torque (In. - lbs.)

Electrical Diagram - Single Phase Units 208 - 230 Volts

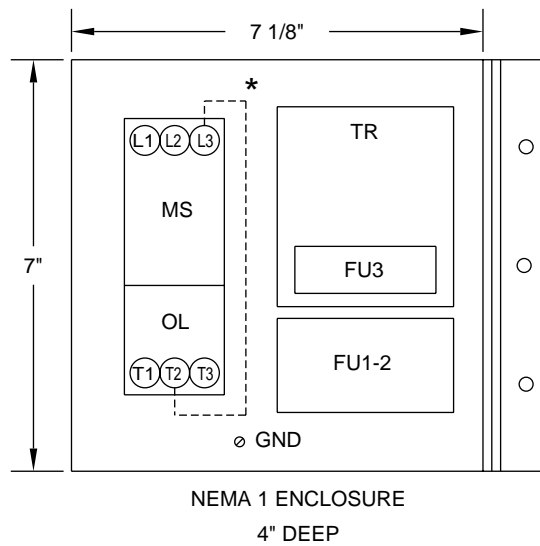
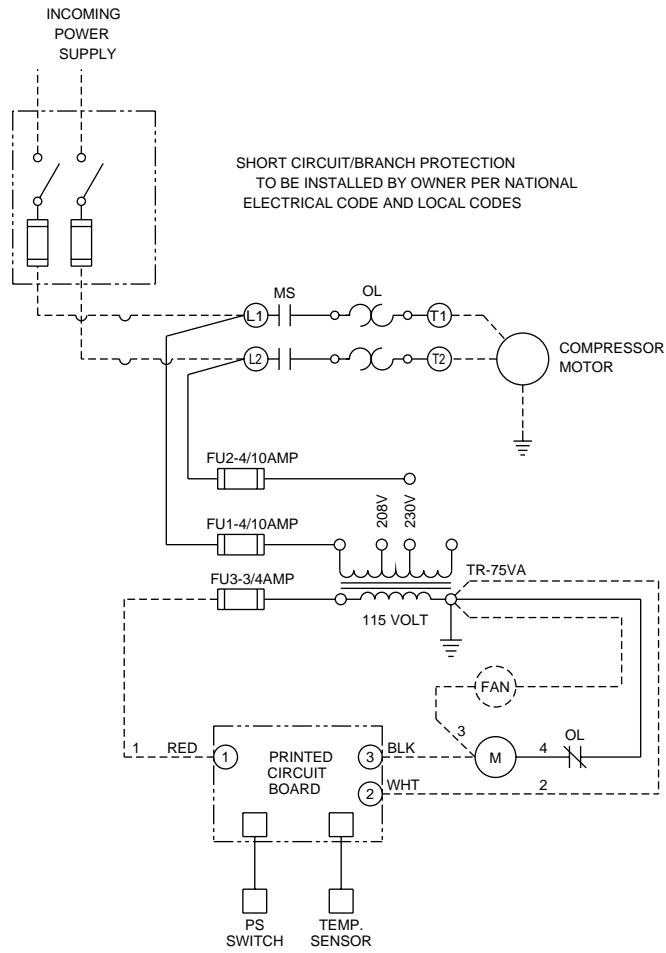

Figure 4

Scroll Enclosure Air Compressors

Electrical Diagram - Three Phase Units 208 - 230 - 460 Volts

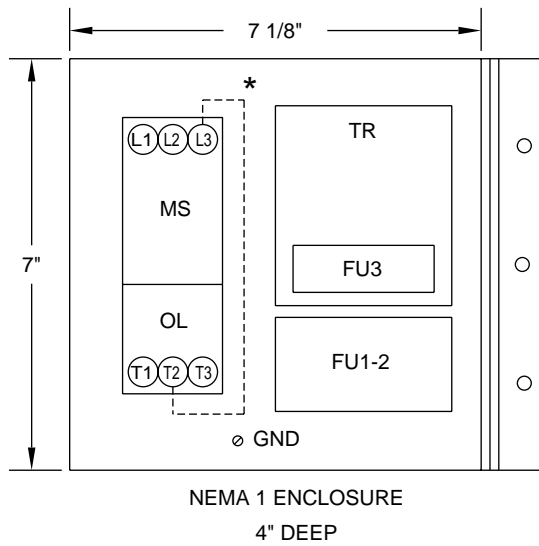
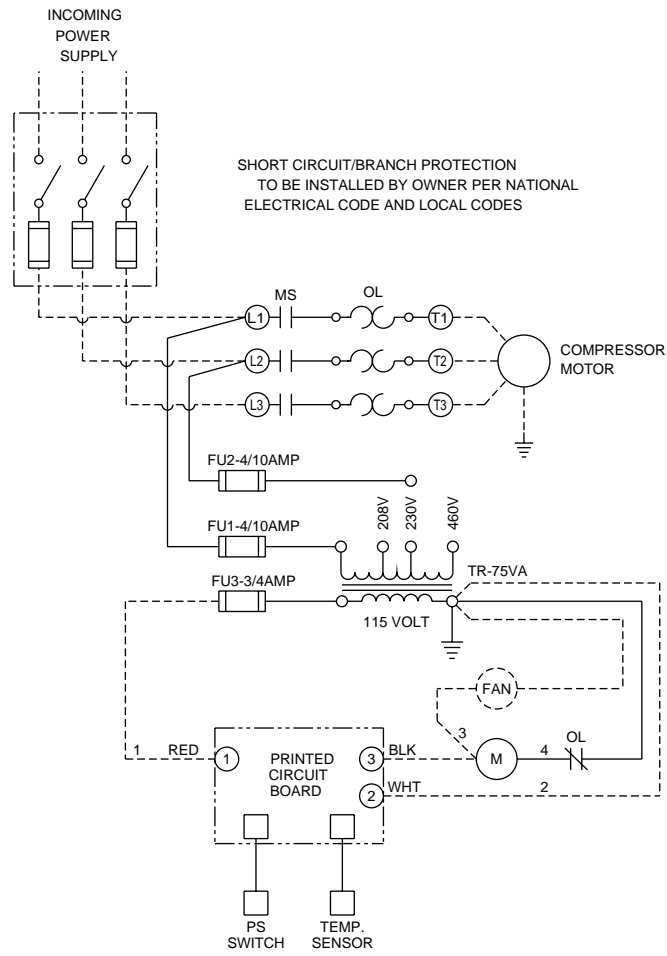

Figure 5

Scroll Airend Parts Breakdown -

MODELS SLAE03 (SL0140) FOR 3 HP AND SLAE05 (SL0165) FOR 5 HP

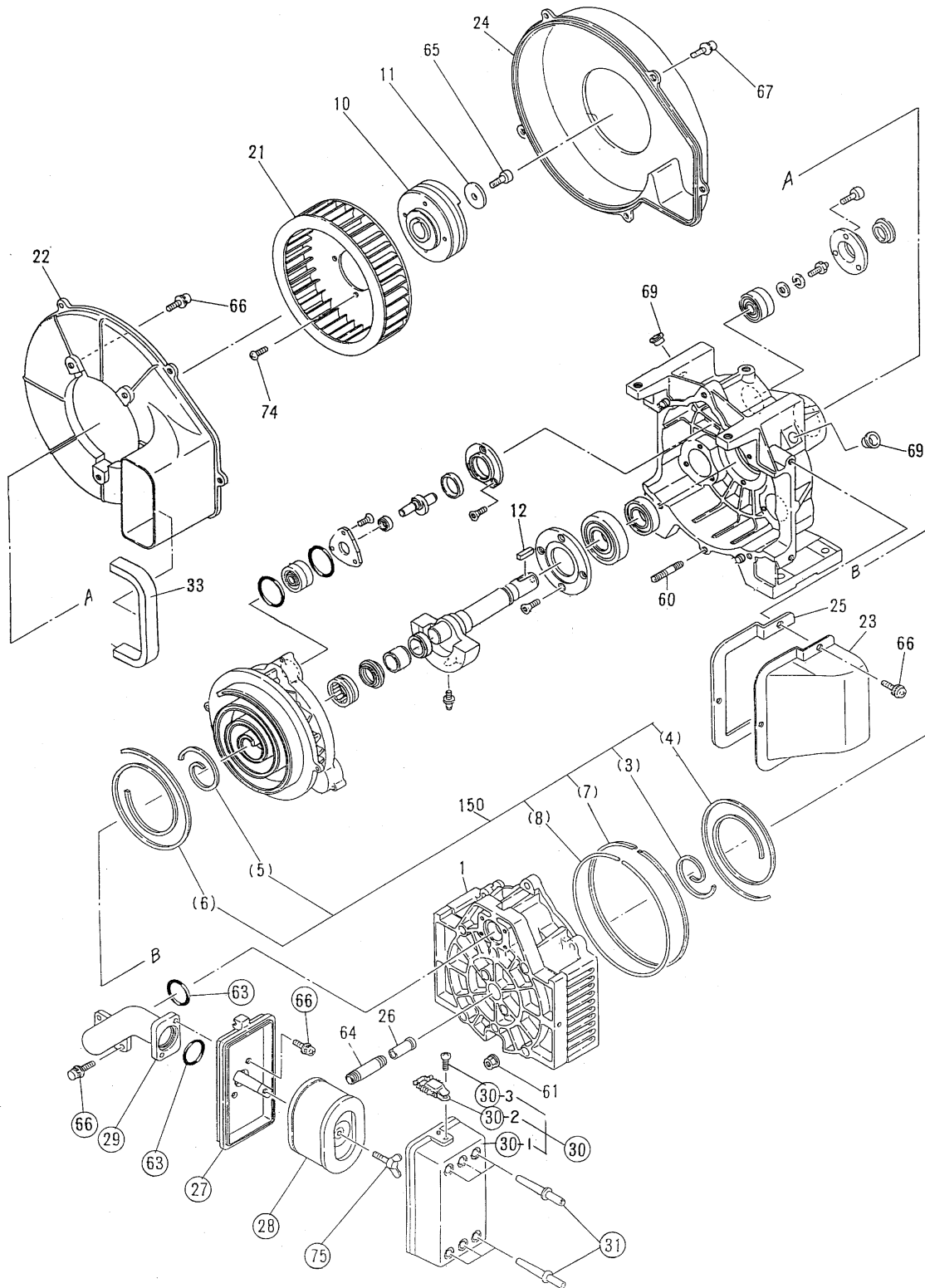

Figure 6

Scroll Enclosure Air Compressors

Replacement Parts List

Ref. No.	Description	SLAE03 Part Number	Qty.	SLAE05 Part Number	Qty.
1	Stational scroll set	IP600100AV	1	IP600200AV	1
10	Airend pulley	IP600300AV	1	IP600400AV	1
11	Washer - sheave	IP600500AV	1	IP600500AV	1
12	Key	IP600600AV	1	IP600600AV	1
14	▲ Pin crank holder	—	—	—	—
15	▲ Pin crank bolt	—	—	—	—
18	▲ Bearing cover (2)	—	—	—	—
21	Centrifugal fan	IP601300AV	1	IP601300AV	1
22	Fan duct (1)	IP601400AV	1	IP601400AV	1
23	Fan duct (2)	IP601500AV	1	IP601600AV	1
24	Fan cover	IP601700AV	1	IP601700AV	1
25	Fan dust gasket (1)	IP601800AV	1	IP601900AV	1
26	Heat insulation pipe	IP602000AV	1	IP602000AV	1
27	Filter plate	IP602100AV	1	IP602100AV	1
28	Cartridge filter	IP032901AV	1	IP032901AV	1
29	Intake pipe	IP602200AV	1	IP602200AV	1
30	Intake filter cover	IP016101AV	1	IP016101AV	1
31	Filter cover pipe	IP602300AV	6	IP602300AV	6
33	Fan duct gasket (2)	IP602400AV	1	IP602400AV	1
49	▲ Grease nipple	—	—	—	—
60	Stud bolt	IP602600AV	6	IP602700AV	6
61	Nut with washer	IP602800AV	6	IP602900AV	6
62	▲ O-ring	—	—	—	—
63	O-ring	IP603200AV	2	IP603200AV	2
64	Long nipple	IP603300AV	1	IP603300AV	1
65	Hex. socket head bolt	IP603400AV	1	IP603400AV	1
66	Combination washer/bolt	IP605700AV	11	IP605700AV	11
67	Tapping screw	IP605800AV	5	IP605800AV	5
69	Dust cap	IP603500AV	2	IP603500AV	2
70	▲ Hex. socket bolt	—	—	—	—
71	▲ Hex. socket head bolt	—	—	—	—
72	▲ Grease cap	—	—	—	—
73	▲ Hex. socket head bolt	—	—	—	—
74	Button bolt	IP604100AV	4	IP604100AV	4
75	Wing bolt	IP604200AV	1	IP604200AV	1
76	▲ Lock washer	—	—	—	—
100	▲ O.S. Bearing set	—	—	—	—
150	Tip seal set	IP604500AV	1	IP604600AV	1
200	▲ Crank shaft seal	—	—	—	—
250	▲ Needle bearing set	—	—	—	—
250	▲ Roller bearing set	—	—	—	—
300	▲ Pin crank set	—	—	—	—
350	▲ Grease seal support set	—	—	—	—
400	▲ Bearing cover set	—	—	—	—
450	▲ Housing set	—	—	—	—

▲ = Replace Pump

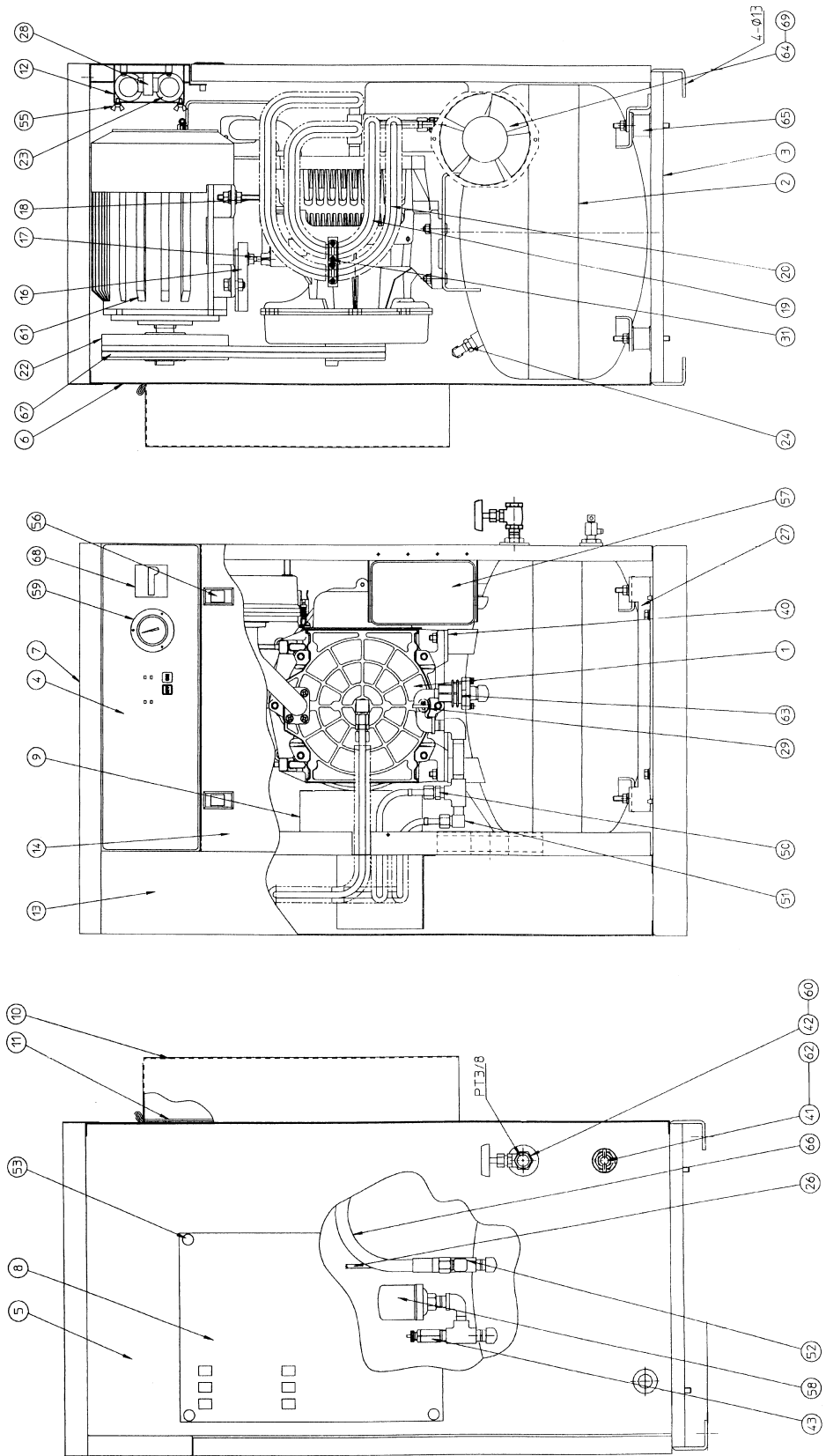

Figure 7

Replacement Parts

Ref. No.	Description	Part Number		Qty.
		SLAE03	SLAE05	
1	Airend	SL014000AV	SL016500AV	1
2	Tank set	AR032900AV	AR032900AV	1
3	Base	IP630800AV	AP603800AV	1
4	Control panel set	IP630600AV	IP630600AV	1
5	Right panel set	IP631600AV	IP631600AV	1
6	Rear panel set	IP631400AV	IP631400AV	1
7	Top panel set	IP631200AV	IP631200AV	1
8	Intake panel set	IP631300AV	IP631300AV	1
10	Exhaust duct set	IP630900AV	IP630900AV	1
11	Metal screen	IP630700AV	IP630700AV	1
12	Circuit board protector	IP632100AV	IP632100AV	1
13	Left panel set	IP631500AV	IP631500AV	1
14	Door set	IP631100AV	IP631100AV	1
15	3-5 HP Scroll inside panel	IP631700AV	IP631700AV	1
16	Motor mount	SL030000AV	SL050000AV	1
17	Support bracket	SL030100AV	SL050100AV	1
18	Stud bolt	IP606000AV	IP605900AV	2
19	Aftercooler tube (1)	IP608600AV	IP608600AV	1
20	Aftercooler tube (2)	IP608700AV	IP608700AV	1
22	Motor pulley 6.0PD 3V-1	PU009753AV	—	1
22	Motor pulley 6.5PD 3V-2	—	PU009754AV	1
23	Special grommet	IP608900AV	IP608900AV	2
24	Drain tube	IP637200AV	IP637200AV	1
26	Plastic tubing	PS010300AV	PS010300AV	1.5 ft.
27	Shipping bracket	IP632200AV	IP632200AV	1
28	Circuit board	IP087800AV	IP087800AV	1
29	Thermosensor	IP609600AV	IP609700AV	1
31-1	Aftercooler bracket	IP610100AV	IP610100AV	1
31-2	Aftercooler bracket	IP610200AV	IP610200AV	1
40	Isolation rubber	RE002600AV	RE002600AV	4
41	Drain flange fitting	PS006701AV	PS006701AV	1
42	Outlet flange fitting	PS006702AV	PS006702AV	1
43	Safety valve	V-215104AV	V-215104AV	1
50	Flare fitting	ST126225AV	ST126225AV	2
51	Flare elbow	ST126229AV	ST126229AV	2
53	Pan head machine screw	ST074003AV	10	10

Ref. No.	Description	Part Number		Qty.
		SLAE03	SLAE05	
55	Stand-off	IP632900AV	IP632900AV	2
56	Recessed door latch	IP630200AV	IP630200AV	1
57	Starter box 3PH	SL020011AV	SL020011AV	1
57	Starter box 1PH	SL020021AV	SL020021AV	1
57	Starter box 3PH	—	SL020030AV	1
57	Starter box 1PH	—	SL020041AV	1
57-1	Starter brace	SL050200AV	SL050200AV	—
58	Pressure switch	CW207543AV	CW207543AV	1
59	Pressure gauge	IP632600AV	IP632600AV	1
60	Ball valve 3/8"	ST079802AV	ST079802AV	1
61	Motor 3HP 1PH 230V	MC301519AV	—	1
61	Motor 3HP 3PH 208/230/460V	MC022374AV	—	1
61	Motor 5HP 1PH 230V	—	MC301520AV	1
61	Motor 5HP 3PH 208/230/460V	—	MC022307AV	1
62	1/4" Ball valve	ST079806AV	ST079806AV	1
63	Check valve	CV003204AV	CV003204AV	1
64	Exhaust fan set	IP632400AV	IP632400AV	1
65	Isolation stud	IP630300AV	IP630300AV	4
66	Discharge air hose	IP633600AV	IP633600AV	1
67	V-belt 3V-375	BT009100AV	—	1
67	V-belt 3V-400	—	BT009000AV	2
68	Hour meter	IP632700AV	IP632700AV	1
▲	Power supply cord	IP612800AV	IP612800AV	1

▲ = Not shown

Powerex Limited Warranty

Powerex 3 Year / 10,000 Hour Extended Parts Limited Warranty - Powerex warrants each Compressor Pump or Scroll Air-End against defects in material or workmanship from the date of purchase for a period of **Three years or 10,000 hours**, whichever may occur first. This warranty applies to the exchange of part(s) of the compressor pump or air-end found to be defective by an Authorized Powerex Service Center.

Powerex 1 Year / 5,000 Hour Inlet to Outlet Limited Warranty - Powerex warrants each Compressor Unit, System, Pump, or Air-End against defects in material or workmanship from the date of purchase for a period of **One Year or 5,000 Hours**, whichever may occur first. This warranty applies to the exchange of defective component part(s) and labor performed by an Authorized Powerex Service Center.

The above mentioned warranty applies to POWEREX manufactured units or systems only.

Items listed in the operator's manual under routine maintenance are not covered by this or any other warranty.

THERE IS NO OTHER EXPRESS WARRANTY. IMPLIED WARRANTIES, INCLUDING THOSE OF MERCHANTABILITY AND FITNESS FOR A PARTICULAR PURPOSE, ARE LIMITED TO ONE YEAR FROM THE DATE OF PURCHASE: AND TO THE EXTENT PERMITTED BY LAW, ANY AND ALL IMPLIED WARRANTIES ARE EXCLUDED. THIS IS THE EXCLUSIVE REMEDY AND LIABILITY FOR CONSEQUENTIAL DAMAGES UNDER ANY AND ALL WARRANTIES IS EXCLUDED TO THE EXTENT EXCLUSION IS PERMITTED BY LAW.

All claims pertaining to the merchandise in this schedule, with the exception of warranty claims, must be filed with POWEREX within 6 months of the invoice date, or they will not be honored. Prices, discounts and terms are subject to change without notice or as stipulated in specific product quotations. All agreements are contingent upon strikes, accidents, or other causes beyond our control. All shipments are carefully inspected and counted before leaving the factory. Please inspect carefully any receipt of merchandise noting any discrepancy or damage on the carrier's freight bill at the time of delivery. Discrepancies or damage which obviously occurred in transit are the carrier's responsibility and related claims should be made promptly directly to the carrier. Returned merchandise will not be accepted without prior written authorization by POWEREX and deductions from invoices for shortage or damage claims will not be allowed.

UNLESS OTHERWISE AGREED TO IN WRITING, THESE TERMS AND CONDITIONS WILL CONTROL IN ANY TRANSACTION WITH POWEREX any different or conflicting terms as may appear on any order form now or later submitted by the buyer. All orders are subject to acceptance by POWEREX.